

# User's Manual

## **SMARC Computer on Module**

- Freescale i.MX6 Cortex A9
- 24bits Parallel LCD/LVDS/HDMI
- 4 x COM Ports
- 2 x SDHC
- 1 x USB Host 2.0, 1 x USB OTG
- 1 x 10/100/1000M Gigabit Ethernet
- 2 x CAN Bus, 2 x SPIs, 4 x I2Cs
- 1 x PCIe, 1 x SATA, 1 x MIPI

## **SMARC-FiMX6**





*Revision History*

<i>Revision</i>	<i>Date</i>	<i>Changes from Previous Revision</i>
<i>1.0</i>	<i>2014/11/20</i>	<i>Initial Release</i>
<i>1.2</i>	<i>2015/2/25</i>	<i>Documentation Wording Fixed and add section 2.1.8 and add Ethernet MAC EEPROM information</i>

## **USER INFORMATION**

### ***About This Manual***

This document provides information about products from EMBEDIAN, INC. No warranty of suitability, purpose, or fitness is implied. While every attempt has been made to ensure that the information in this document is accurate, the information contained within is supplied “as-is” and is subject to change without notice.

For the circuits, descriptions and tables indicated, EMBEDIAN assumes no responsibility as far as patents or other rights of third parties are concerned.

### ***Copyright Notice***

Copyright © 2014 EMBEDIAN, INC..

All rights reserved. No part of this manual may be reproduced, transmitted, transcribed, stored in a retrieval system, or translated into any language or computer language, in any form or by any means (electronic, mechanical, photocopying, recording, or otherwise), without the express written permission of EMBEDIAN.

### ***Trademarks***

The following lists the trademarks of components used in this board.

- ARM is a registered trademark of ARM Limited.
- Android is a registered trademark of Google
- Linux is a registered trademark of Linus Torvalds.
- WinCE is a registered trademark of Microsoft
- TI is a registered trademark of Texas Instruments
- All other products and trademarks mentioned in this manual are trademarks of their respective owners.

### ***Standards***

EMBEDIAN is ISO 9001:2008 and ISO14001-certified manufacturer. SMARC is an SGET standard for ARM computer on module.

### ***Warranty***

This EMBEDIAN product is warranted against defects in material and workmanship for the warranty period from the date of shipment. During the warranty period, EMBEDIAN will at its discretion, decide to repair or replace defective products.

Within the warranty period, the repair of products is free of charge as long as warranty conditions are observed.

The warranty does not apply to defects resulting from improper or inadequate maintenance or handling by the buyer, unauthorized modification or misuse, operation outside of the product’s environmental specifications or improper installation or maintenance.



## ***Embedian, Inc.***

EMBEDIAN will not be responsible for any defects or damages to other products not supplied by EMBEDIAN that are caused by a faulty EMBEDIAN product.

### ***Technical Support***

Technicians and engineers from EMBEDIAN and/or its subsidiaries and official distributors are available for technical support. We are committed to making our product easy to use and will help you use our products in your systems.

Before contacting EMBEDIAN technical support, please consult our Web site for the latest product documentation, utilities, and drivers. If the information does not help solve the problem, contact us by e-mail or telephone.

## Table of Contents

CHAPTER 1 INTRODUCTION.....	10
1.1 FEATURES AND FUNCTIONALITY.....	10
1.2 MODULE VARIANT.....	12
1.3 BLOCK DIAGRAM.....	13
1.4 SOFTWARE SUPPORT / HARDWARE ABSTRACTION.....	14
1.5 DOCUMENT AND STANDARD REFERENCES.....	14
CHAPTER 2 SPECIFICATIONS.....	18
2.1 SMARC-FIMX6 GENERAL FUNCTIONS.....	18
2.2 SMARC-FIMX6 DEBUG.....	94
2.3 MECHANICAL SPECIFICATIONS.....	94
2.4 ELECTRICAL SPECIFICATIONS.....	109
2.5 ENVIRONMENTAL SPECIFICATIONS.....	114
CHAPTER 3 CONNECTOR PINOUT.....	116
3.1 SMARC-FIMX6 CONNECTOR PIN MAPPING.....	116
CHAPTER 4 POWER CONTROL SIGNALS BETWEEN SMARC-FIMX6 MODULE AND CARRIER.....	147
4.1 SMARC-FIMX6 MODULE POWER.....	147
4.2 POWER SIGNALS.....	152
4.3 POWER FLOW AND CONTROL SIGNALS BLOCK DIAGRAM.....	156
4.4 POWER STATES.....	158
4.5 POWER SEQUENCES.....	159
4.6 TERMINATIONS.....	163
4.7 BOOT DEVICE SELECTION.....	167

## Using this Manual

This guide provides information about the Embedian *SMARC-FiMX6* for Freescale *i.MX6* embedded *SMARC* core module family.

### Conventions used in this guide

This table describes the typographic conventions used in this guide:

<i>This Convention</i>	<i>Is used for</i>
<i>Italic type</i>	Emphasis, new terms, variables, and document titles.
monospaced type	Filenames, pathnames, and code examples.

### Embedian Information

#### Document Updates

Please always check the product specific section on the Embedian support website at [www.embedian.com/](http://www.embedian.com/) for the most current revision of this document.

#### Contact Information

For more information about your Embedian products, or for customer service and technical support, contact Embedian directly.

<i>To contact Embedian by</i>	<i>Use</i>
Mail	Embedian, Inc. 4F-7. 432 Keelung Rd. Sec. 1, Taipei 11051, Taiwan
World Wide Web	<a href="http://www.embedian.com/">http://www.embedian.com/</a>
Telephone	+ 886 2 2722 3291

### Additional Resources

Please also refer to the most recent Freescale *i.MX6* processor reference

*Embedian, Inc.*

manual and related documentation for additional information.

# Chapter 1

## Introduction

This Chapter gives background information on the *SMARC-FiMX6*

Section include :

- Features and Functionality
- Module Variant
- Block diagram
- Software Support / Hardware Abstraction
- Module Variant
- Document and Standard References

# Chapter 1 Introduction

The **SMARC®** (**S**mart **M**obility **AR**chitecture) *FiMX6* is a versatile small form factor Computer-On-Module with *Freescale i.MX6* processor and offers a wide range of processor scalability with single, dual and quadcore processors. The X86 alike interfacing of *SMARC-FiMX6* allows an easy integration in any kind of application.

The module connector has 314 edge fingers that mate with a low profile 314 pin 0.5mm pitch right angle connector (this connector is sometimes identified as an 321 pin connector, but 7 pins are lost to the key).

Featuring Freescale's *i.MX6* System-on-Chip, Embedian's *SMARC-FiMX6* offers 24-bit Parallel LCD, single- or dual-channel LVDS, Gigabit Ethernet, HDMI, SDHC, USB 2.0, USB OTG, four UARTs support and many peripheral interfaces in a cost effective, low power, miniature package. Embedian's *SMARC-FiMX6* thin and robust design makes it an ideal building block for reliable system design.

The module is the ideal choice for a broad range of target markets including

- HVAC Building and Control Systems
- Rear seat and in-freight entertainment system.
- Smart Grid and Smart Metering
- Digital Signage
- HMI/ In-Home Display
- Smart Toll Systems
- Connected Vending Machines
- Display Unit
- General Control System
- And more

Complete and cost-efficient Embedian evaluation kits for Yocto, Ubuntu 12.04, Android ICS and Microsoft Windows Embedded Compact 7 allow immediate and professional embedded product development with dramatically reduced design risk and time-to-market.

## 1.1 Features and Functionality

The *SMARC-FiMX* module is based on the *i.MX6* processor with solo, dual lite, dual and quad core from Freescale. This processor offers a high number of interfaces. The module has the following features:

- *SMARC* 1.0 or 1.1 compliant in an 82mm x 50mm form factor.

## *Embedian, Inc.*

- Processor: *Freescale i.MX6* ARM Cortex-A9 up to 1GHz
- Memory: Onboard 8GB eMMC Flash and 4MB SPI NOR Flash
- Onboard 1GB or 2GB DDR3 <sup>Note 1</sup>
- Networking: 1 x 10/100/1000 Mbps Ethernet
- Display: 24-bit Parallel LCD
  - Single channel LVDS LCD 18 or 24 bit or dual channel LVDS
  - HDMI
- Expansion: 2 x SDHC/SDIO, 1 x USB 2.0 Host
- USB: 1 x USB 2.0 Host, 1 x USB 2.0 OTG, 1 x PCIe
- A single 4KB EEPROM is provided on I2C0 that holds the board information. This information includes board name, serial number, and revision information.
- Additional Interface:
  - ◆ 4 x UARTs
  - ◆ 2 x SPI
  - ◆ 4 x I2C
  - ◆ 1 x I2S
  - ◆ 2 x CAN Bus
  - ◆ 1 x PWM
  - ◆ 12 x GPIOs
  - ◆ 1 x SATA (Dual and Quad only)
  - ◆ WDT
- SW Support: L:inux, Yocto, Ubuntu, Android ICS, Windows Embedded Compact 7
- Power Consumption (Typcal)
  - ◆ Solo Core (512MB DDR3): 1.55 Watts
  - ◆ Dual Lite Core (1GB DDR3): 2.2 Watts
  - ◆ Dual Core (1GB DDR3): 2.5 Watts
  - ◆ Quad Core (1GB DDR3): 3.6 Watts
- Thermal:
  - ◆ Normal Temperature: 0°C ~ 60°C
  - ◆ Industrial Temperature: -40° ~85°C
- Power Supply
- 3V to 5.25V (single 5V is recommended in non-battery operation)
- 3.3V or 1.8V module IO support

### **Note1:**

*SMARC-FiMX6-S* (solo core) only has 512MB DDR3 on board

*SMARC-FiMX6-U* (dual lite core) only has 1GB DDR3 memory on board (no 2GB option for this variant.)

## 1.2 Module Variant

The *SMARC-FiMX6* module is available with various options based on processors in this family from Freescale, DDR3 memory configuration, voltage rail of VDDIO and operating temperature ranges.

SMARC-FiMX6-X-YY-Z-W  
          ↑   ↑   ↑   ↑  
          1   2   3   4

- 1: “S” (solo core running up to 1GHz)  
“U” (dual lite core running up to 1GHz)  
“D” (dual core running up to 1GHz)  
“Q” (quad core running up to 1GHz)
- 2: “1G” (1GB DDR3 memory)  
“2G” (2GB DDR3 memory, only for dual and quad core)
3. “P” (if 1.8V VDDIO)  
Leave it Blank if 3.3V VDDIO
4. “I” (Industrial temperature (-40°C~85°C), CPU running up to 800MHz)  
Leave it Blank if normal temperature

For example, *SMARC-FiMX-D-1G* stands for dual core *i.MX6* processor running up to 1GHz with 1GB DDR3 memory in normal operating temperature. The VDDIO voltage rail is 3.3V (*SMARC* spec. 1.0 compliant).



### 1.3 Block Diagram

The following diagram illustrates the system organization of the *SMARC-FiMX6*. Arrows indicate direction of control and not necessarily signal flow.

Figure 1: *SMARC-FiMX6* Block Diagram

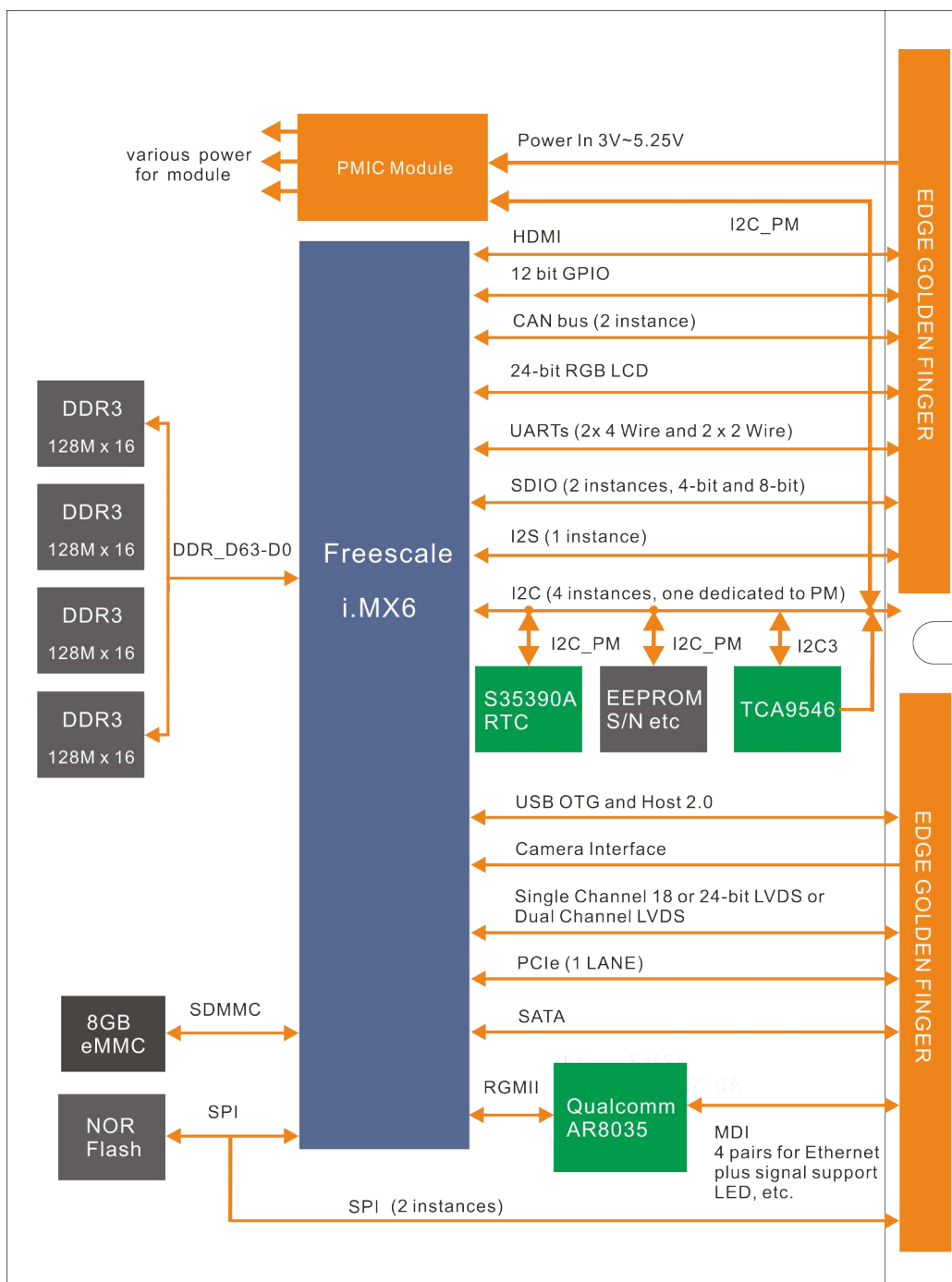

Details for this diagram will be explained in the following chapters.

## **1.4 Software Support / Hardware Abstraction**

The Embedian *SMARC-FiMX6* Module is supported by Embedian BSPs (Board Support Package). The first *SMARC-FiMX6* BSP targets Linux (Ubuntu 14.04 LTS and Yocto Project) and Android support. BSPs for other operating systems are planned. Check with your Embedian contact for the latest BSPs. This manual goes into a lot of detail on I/O particulars – information is provided on exactly how the various *SMARC* edge fingers tie into the Freescale i.MX6 SoC and to other Module hardware. This is provided for reference and context. Almost all of the I/O particulars are covered and abstracted in the BSP and it should generally not be necessary for users to deal with I/O at the register level.

## **1.5 Document and Standard References**

### **1.5.1. External Industry Standard Documents**

- **eMMC (Embedded Multi-Media Card)** the eMMC electrical standard is defined by JEDEC JESD84-B45 and the mechanical standard by JESD84-C44 ([www.jedec.org](http://www.jedec.org)).
- **The I2C Specification**, Version 2.1, January 2000, Philips Semiconductor (now NXP) ([www.nxp.com](http://www.nxp.com)).
- **I2S Bus Specification**, Feb. 1986 and Revised June 5, 1996, Philips Semiconductor (now NXP) ([www.nxp.com](http://www.nxp.com)).
- **JTAG (Joint Test Action Group)** defined by IEEE 1149.1-2001 - IEEE Standard Test Access Port and Boundary Scan Architecture ([www.ieee.org](http://www.ieee.org)).
- **MXM3 Graphics Module Mobile PCI Express Module Electromechanical Specification**, Version 3.0, Revision 1.1, © 2009 NVIDIA Corporation ([www.mxm-sig.org](http://www.mxm-sig.org)).
- **PICMG® EEPROM Embedded EEPROM Specification**, Rev. 1.0, August 2010 ([www.picmg.org](http://www.picmg.org)).
- **SD Specifications Part 1 Physical Layer Simplified Specification**, Version 3.01, May 18, 2010, © 2010 SD Group and SD Card Association (Secure Digital) ([www.sdcard.org](http://www.sdcard.org)).
- **SPI Bus** – “Serial Peripheral Interface” - de-facto serial interface standard defined by Motorola. A good description may be found on Wikipedia ([http://en.wikipedia.org/wiki/Serial\\_Peripheral\\_Interface\\_Bus](http://en.wikipedia.org/wiki/Serial_Peripheral_Interface_Bus)).
- **USB Specifications** ([www.usb.org](http://www.usb.org)).
- **Serial ATA Revision 3.1**, July 18, 2011, Gold Revision, © Serial ATA

## **Embedian, Inc.**

- International Organization ([www.sata-io.org](http://www.sata-io.org))
- **PCI Express Specifications** ([www.pci-sig.org](http://www.pci-sig.org))
- **SPDIF (aka S/PDIF) ("Sony Philips Digital Interface)- IEC 60958-3**
- 

### **1.5.2. SGET Documents**

- **SMARC\_Hardware\_Specification\_V1p0**, version 1.0, December 20, 2012.
- **SMARC\_Hardware\_Specification\_V1p1**, version 1.1, May 29, 2014.
- **Smart Mobility Architecture Design Guide**, version 1.0, July 9, 2013
- **Smart Mobility Architecture Design Guide**, version 1.1, May 29, 2014

### **1.5.3. Embedian Documents**

The following documents are listed for reference. The Module schematic is not usually available outside of Embedian, without special permission. The other schematics will be available. Contact your Embedian representative for more information. The *SMARC* Evaluation Carrier Board Schematic is particularly useful as an example of the implementation of various interfaces on a Carrier board.

- **SMARC Evaluation Carrier Board Schematic**, PDF and OrCAD format
- **SMARC Evaluation Carrier Board User's Manual**
- **SMARC-FiMX6 User's Manual**
- **SMARC-FiMX6 Schematic Checklist**

### **1.5.4. Freescale Documents**

- **IMX6DQRM, i.MX 6Dual/6Quad Applications Processor Reference Manual**, May 2014 (rev. 2)
- **IMX6DQ6SDLHDG, Hardware Development Guide for i.MX 6Quad, 6Dual, 6DualLite, 6Solo Families of Applications Processors**, June 2013 (rev. 1)
- **AN4059, i.MX 6Dual/6Quad Power Consumption Measurement**, Oct 2012 (rev. 0)

### **1.5.5. Freescale Development Tools**

- ***IOMUX\_TOOL for ARM® i.MX6 Microprocessors***
- ***IMX\_CST\_TOOL***, Freescale Code Signing Tool for the High Assurance Boot library.

### **1.5.6. Freescale Software Documents**

- ***L3.0.101\_SOURCE\_BSP***, i.MX 6Quad, i.MX 6Dual, i.MX 6DualLite, i.MX 6Solo and i.MX 6Sololite Linux BSP Source Code Files. Nov 3, 2014 (Rev.# L3.0.101)
- ***Fsi-L3.10.17\_1.0.2\_iMX6QDLS\_BUNDLE***, i.MX 6Quad, i.MX 6Dual, i.MX 6DualLite, i.MX 6Solo Linux Binary Demo Files and Linux BSP Documentation. Oct. 29, 2014 (Rev.# L3.10.17)
- ***IMX6\_JB43\_110\_ANDROID\_SOURCE\_BSP***, i.MX 6Quad, i.MX 6Dual, i.MX 6DualLite, i.MX 6Solo and i.MX 6Sololite Android jb4.3\_1.1.0 0 BSP, Documentation and Source Code for BSP and Codecs. Dec. 19, 2013 (Rev.# jb4.3\_1.1.0)
- ***IMX6\_KK442\_100\_ANDROID\_SOURCE\_BSP***, i.MX 6Quad, i.MX 6Dual, i.MX 6DualLite, i.MX 6Solo and i.MX 6Sololite Android KK4.4.2\_1.0.0 BSP, Source Code for BSP and Codecs. July 14, 2014 (Rev.# KK442.2\_1.0.0)

### **1.5.7. Embedian Software Documents**

- ***Embedian Linux BSP for SMARC-FiMX6 Module***
- ***Embedian Android BSP for SMARC-FiMX6 Module***
- ***Embedian Linux BSP User's Guide***
- ***Embedian Android BSP User's Guide***

### **1.5.8. Freescale Design Network**

- ***SABRE***
- ***Wandboard***
- ***Nucleus***
- ***QNX***

# Chapter 2

## Specifications

This Chapter provides SMARC-FiMX6 specifications.  
Section include :

- *SMARC-FiMX6* General Functions
- *SMARC-FiMX6* Debug
- Mechanical Specifications
- Electrical Specification
- Environment Specification

# Chapter 2 Specifications

## 2.1 SMARC-FiMX6 General Functions

### 2.1.1. SMARC-FiMX6 Feature Set

This section lists the complete feature set supported by the *SMARC-FiMX6* module.

<b>SMARC Feature Specification</b>	<b>SMARC Specification Maximum Number Possible</b>	<b>SMARC-FiMX6 Feature Support</b>	<b>SMARC-FiMX6 Feature Support Instances</b>
<b>LVDS Display Support</b>	1	Yes	1 (18 or 24 bits) <sup>Note1</sup>
<b>Parallel LCD Support</b>	1	Yes	1 (24 bits)
<b>HDMI Display Support</b>	1	Yes	1
<b>CSI Camera Support (Dual and Quad lanes)</b>	2	Yes	1 (Quad Lane)
<b>Serial Camera Support</b>	2	Yes	1 (4 lanes)
<b>USB Interface</b>	3	Yes	2
<b>PCIe Interface</b>	3	Yes	1 (one Lane)
<b>SATA Interface</b>	1	Yes	1 (0 on Solo and DualLite)
<b>GbE Interface</b>	1	Yes	1
<b>SDIO Interface (4bit)</b>	1	Yes	1 (max. 25MHz)
<b>SDMMC Interface (8bit)</b>	1	Yes	1 (max. 25MHz)
<b>SPI Interface</b>	2	Yes	2
<b>I2S Interface</b>	3	Yes	1
<b>I2C Interface</b>	5	Yes	5
<b>Serial</b>	4	Yes	4
<b>CAN</b>	2	Yes	2

<i>SMARC Feature Specification</i>	<i>SMARC Specification Maximum Number Possible</i>	<i>SMARC-FiMX6 Feature Support</i>	<i>SMARC-FiMX6 Feature Support Instances</i>
<i>AFB</i>		Yes	<i>Dual Channel LVDS is realized<sup>Note2</sup></i>
<i>I/O Voltage (1.8V) Level Support</i>		Yes	
<i>I/O Voltage (3.3V) Level Support</i>		Yes	

**Note:**

1. Single channel LVDS interface: 1 x 18 bpp OR 1 x 24 bpp (up to 85 MHz per interface e.g 1366x768 @ 60Hz + 35% blanking)
2. Dual channel LVDS interface: 2 x 18 bpp OR 2 x 24 bpp (up to 170 MHz pixel clock e.g 1600x1200 @ 60 Hz + 35% blanking).

**2.1.2. Form Factor**

The *SMARC-FiMX6* module complies with the *SMARC* General Specification module size requirements in an 82mm x 50mm form factor.

### 2.1.3. CPU

The SMARC-FiMX6 implements Freescale's i.MX6 ARM processor.

<b>Freescale CPU</b>	<b>i.MX6 Solo</b>	<b>i.MX6 DualLite</b>	<b>i.MX6 Dual</b>	<b>i.MX6 Quad</b>
<b>Cores</b>	1	2	2	4
<b>Clock<sup>Note1</sup></b>	1GHz	1GHz	1GHz	1GHz
<b>Memory Speed</b>	DDR3-400	DDR3-400	DDR3-533	DDR3-533
<b>Memory Bus</b>	32-bit	64-bit	64-bit	64-bit
<b>Cache</b>	512KB L2	512KB L2	1MB L2 + VFPv3	1MB L2 + VFPv3
<b>GFX</b>	Vivante	Vivante	Vivante	Vivante
<b>GFX core frequency</b>	528MHz	528MHz	528MHz	528MHz
<b>IPUs</b>	1	1	2	2
<b>LVDS</b>	Single or Dual Channel (18-bit or 24-bit)	Single or Dual Channel (18-bit or 24-bit)	Single or Dual Channel (18-bit or 24-bit)	Single or Dual Channel (18-bit or 24-bit)
<b>LVDS Resolutions</b>	Single channel LVDS interface : 1 x 18 bpp or 1 x 24 bpp (up to 85 MHz per interface e.g 1366x768 @ 60Hz + 35% blanking)	Single channel LVDS interface : 1 x 18 bpp or 1 x 24 bpp (up to 85 MHz per interface e.g 1366x768 @ 60Hz + 35% blanking)	Single channel LVDS interface : 1 x 18 bpp or 1 x 24 bpp (up to 85 MHz per interface e.g 1366x768 @ 60Hz + 35% blanking)	Single channel LVDS interface : 1 x 18 bpp or 1 x 24 bpp (up to 85 MHz per interface e.g 1366x768 @ 60Hz + 35% blanking)  Dual channel LVDS interface: 2 x 18 bpp OR 2 x 24 bpp (up to 170 MHz pixel clock e.g 1600x1200 @ 60 Hz + 35% blanking).
<b>Parallel LCD Resolutions</b>	1920x1080x60	1920x1080x60	1920x1080x60	1920x1080x60
<b>HDMI Resolutions</b>	1920x1080x60	1920x1080x60	1920x1200x60	1920x1200x60



<b>Freescale CPU</b>	<b><i>i.MX6 Solo</i></b>	<b><i>i.MX6 DualLite</i></b>	<b><i>i.MX6 Dual</i></b>	<b><i>i.MX6 Quad</i></b>
<b>3D Graphics</b>	<i>1 shader</i>	<i>1 shader</i>	<i>4 shaders</i>	<i>4 shaders</i>
<b>2D Graphics</b>	<i>X1</i>	<i>X1</i>	<i>X2</i>	<i>X2</i>
<b>Independent Display<sup>Note2</sup></b>	<i>-</i>	<i>-</i>	<i>yes</i>	<i>yes</i>

**Note:**

1. For industrial temp. boards, the clocking speed is only up to 800MHz.
2. The LVDS interface can be used either as a single channel or as a dual channel. It is also possible to use the LVDS interface as two independent single LVDS channels. To do this, it is recommended to configure the LVDS display in the bootloader. Three independent displays are possible when connected as two single LVDS channel and one HDMI interface.

**2.1.4. Module Memory**

The *SMARC-FiMX6* module supports different configurations of DDR3 memory. The following table shows the available options.

<b>SMARC Variants</b>	<b><i>i.MX6 Solo</i></b>	<b><i>i.MX6 DualLite</i></b>	<b><i>i.MX6 Dual</i></b>	<b><i>i.MX6 Quad</i></b>
<b>512MB DDR3</b>	<i>Yes</i>	<i>No</i>	<i>No</i>	<i>No</i>
<b>1GB DDR3</b>	<i>No</i>	<i>Yes</i>	<i>Yes</i>	<i>Yes</i>
<b>2GB DDR3</b>	<i>No</i>	<i>No</i>	<i>Yes</i>	<i>Yes</i>

Check with your Embedian contact or on the Embedian web site for updated information.

**2.1.5. Graphic Core**

The integrated Vivante core based supports:

<b>3D Graphic Core</b>	<i>Vivante GC2000</i>
<b>Shader Cores</b>	<i>Solo: 1 Core</i> <i>Dual Lite: 1 Core</i> <i>Dual: 4 Cores</i> <i>Quad: 4 Cores</i>
<b>2D Core</b>	<i>Vivante GC320</i>
<b>2D Performance</b>	<i>633M pixels / sec raw performance</i>
<b>Vector Graphics Core</b>	<i>Vivante GC355</i>
<b>API (DirectX/OpenGL)</b>	<i>OpenGL ES 1.1/2.0/3.0, OpenCL 1.1 EP, OpenVG 1.1</i>
<b>Hardware Accelerated Video</b>	<i>Encode:</i>  <i>H.264 BP/CBP</i>  <i>H.263 V2</i>  <i>MPEG-4 SP</i>  <i>MPEG-2</i>  <i>MJPEG Baseline</i>  <i>Decode:</i>  <i>MPEG2 MP/HP</i>  <i>MPEG4/Xvid SP/ASP</i>  <i>H.264 BP/MP/HP</i>  <i>H.264 MVC BP/MP/HP</i>  <i>H.263 V2</i>  <i>DivX v3/4/5/6</i>  <i>VC-1 SP/MP/AP</i>  <i>MJPEG Baseline</i>  <i>VP6/VebM VP8</i>

### **2.1.6. Onboard Storage**

The *SMARC-FiMX6* module supports a 8GB eMMC flash memory device, 4MB SPI NOR flash and a 32Kb I2C serial EEPROM on the Module I2C\_PM (I2C0) bus. The device used is an On Semiconductor 24C32 equivalent. The Module serial EEPROM is intended to retain Module parameter information, including a module serial number. The Module serial EEPROM data structure conforms to the PICMG® EEPROM Embedded EEPROM Specification.). The onboard 4MB SPI NOR flash is used as SPI boot media. The module will always boot up from the onboard SPI NOR flash first. The firmware in NOR flash will read the configuration from the boot selection and boot up the devices from that selected.

### **2.1.7. Clocks**

A 32.768 KHz clock is required for the i.MX6 CPU RTC (Real Time Clock) and external (S-35390A) RTC.

The Freescale i.MX6 CPU is provided with a 24 MHz clock using a crystal in normal oscillation mode (On-chip Oscillator).

The Qualcomm AR8035 PHY is provided with a 24 MHz clock using a crystal in normal oscillation mode.

### **2.1.8. Multiple Displays with IPU in i.MX6**

There are basically two limitations which have to be pointed out.

#### ***IPU capabilities***

The two display ports (DI0 and DI1) of each IPU are limited to a combined pixel clock of 240MHz. The maximum clock for a single display port is 220MHz. This results in the following table (for one IPU only):

## Multiple Displays with IPU in i.MX6

Second Display	SDTV	WSVGA	HDTV	WXGA	WSXGA+	HDTV
First Display	480i30 / 576i25 (27 MHz)	1024x600 (44 - 49 MHz)	760p60 / 1080i30 (74.25 MHz)	1366x768 (72 - 85 MHz)	1680x1050 (119 - 146 MHz)	1080p60 (148.5 MHz)
<b>WXGA</b> 1366x768 (72 - 85 MHz)	Full	Full	Full	Full	Full	Full
<b>SXGA</b> 1280x1024 (91 - 109 MHz)	Full	Full	Full	Full	Partial	Partial
<b>SXGA+</b> 1400x1050 (101 - 124 MHz)	Full	Full	Full	Full	Partial	
<b>WSXGA+</b> 1680x1050 (119 - 146 MHz)	Full	Full	Full	Full	Partial	
<b>UXGA</b> 1600x1200 (130 - 161 MHz)	Full	Full	Full	Partial		
<b>WUXGA</b> 1920x1200 (154 - 191 MHz)	Full	Partial	Partial			
<b>9VGA</b> 1920x1440 (185 - 234 MHz)*	Partial	Partial				
<b>4XGA</b> 2048x1536 (209 - 267 MHz)*	Partial					

- The table indicates the performance per IPU. Two IPU's are available in the dual- and quad-core versions of i.MX6.
- For a TV, the clock rate is fixed by the corresponding standards.
- The assumed screen refresh rate for other displays is 60 Hz.
- Resolutions marked with \* are not possible by LVDS.
- **Full** = allowing full blanking which is typical required for CRTs
- **Partial** = allowing only reduced blanking, which is still typical sufficient for digital displays, e.g. LCDs

The table above only describes the capabilities of the display ports to perform screen refresh. A full use case typically includes additional activities like video processing, resizing etc., decreasing the possible display resolutions.

### LVDS Serialization

Another limitation by using the LVDS interfaces is the maximum clock of the LVDS serializer. For single-channel output the pixel clock is limited to 85 MHz per LVDS port. This results in a maximum resolution of WXGA (1366x768 @ 60HZ with 35% blanking), for example. If a higher resolution is needed, the split mode has to be used. In this case one LVDS port outputs ODD data and the other port EVEN data. The pixel clock is limited to 170 MHz (e.g. UXGA 1600x1200 @ 60 Hz with 35% blanking). To use the split mode, you need a display supporting the dual channel LVDS mode in order to receive odd and even pixel data!

### **2.1.9. Parallel LCD Interface**

The Freescale i.MX6 parallel 24 bit LCD interface is brought to the Module edge connector. The interface runs at the 3.3V or 1.8V Module I/O voltage depending on the part number that users select. The *SMARC* Module parallel LCD pins may be used to drive a traditional parallel LCD interface (or they may be used to drive LVDS transmitters or other transmitters that accept parallel LCD data at the Module VDD\_IO level).

For parallel displays with very small form factors (think cell phone and digital camera size), the data I/O level is usually 1.8V. For larger displays, the display will likely require a 3.3V data I/O level.

If the *SMARC* modules are with 3.3V VDD\_IO and parallel displays are with 3.3 V I/O, the *SMARC* Parallel LCD data signals may be passed directly to the display, for short cable runs. This voltage swing may be used directly with 3.3V capable Carrier Board LVDS transmitters, such as the TI *SN75LVDS83B*. The 3.3V signaling is suitable for direct connection to a parallel flat panel in most cases. Generally speaking, larger parallel LCD panels are likely to use 3.3V or 5V signaling. If LCD panels use 5V signaling, a set of voltage translators / buffers would be needed on the Carrier.

If the *SMARC* modules are with 1.8V VDD\_IO and parallel displays are with 1.8V I/O, the *SMARC* Parallel LCD data signals may be passed directly to the display, for short cable runs. For larger displays with 3.3V I/O level and the *SMARC* modules are 1.8V VDD\_IO, a bus transceiver like TI *SN74AVC32T245-ZKE* is required to achieve signal buffering and voltage translation from VDD\_IO to a 3.3V display. If there is a requirement for a display cable longer than a few inches, it may be a good idea to include the buffer even if the display accepts 1.8V I/O. The voltage swing may be used directly with 1.8V capable Carrier Board LVDS transmitters, such as TI *DS90C185*.

The following figure shows the parallel LCD block diagram.

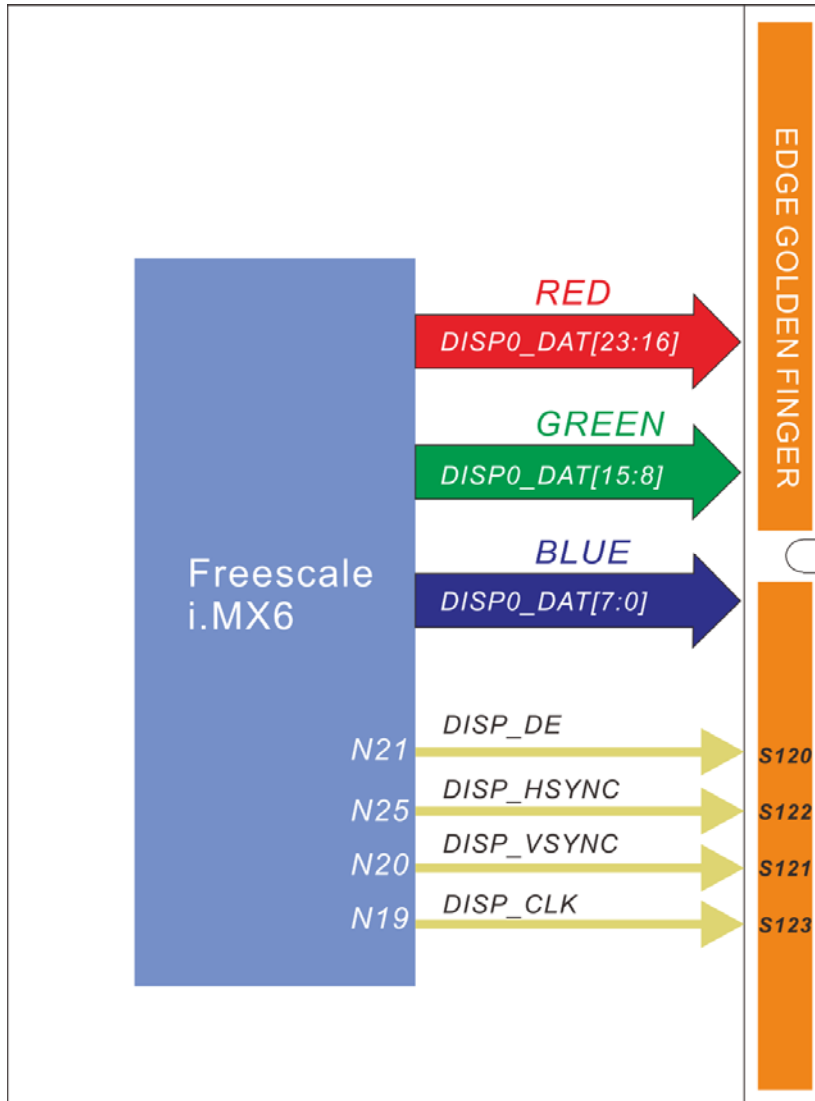

**Figure 2: SMARC-FiMX6 Parallel LCD Diagram**

The mapping of the *Freescale i.MX6* parallel LCD pins to the *SMARC* edge connector is shown in the table below. Basically, Freescale *i.MX6* processor maps the 18 bits of R, G, B for 6 bit color depth to  $DISP0\_DAT[23:18]$ ,  $DISP0\_DAT[15:10]$  and  $DISP0\_DAT[7:2]$ . For *i.MX6*, the extra bits used for a 24 bit color implementation come out on Freescale *i.MX6*  $DISP0\_DAT[17:16]$ ,  $DISP0\_DAT[9:8]$  and  $DISP0\_DAT[1:0]$ . Since 18-bit configuration and 24-bit configuration use the same MSB signals, we can say 18-bit configuration is higher bits subset 24-bit configuration from the hardware point of view. The *SMARC* golden finger has the same convention: Red is  $LCD\_D[23:16]$ ; Blue is  $LCD\_D[15:8]$  and Green is  $LCD\_D[7:0]$ . For 24 bit implementations, all bits are used. For 18 bit implementations, in *SMARC*, the least significant bits (Red  $LCD\_D[17:16]$ , Green  $LCD\_D[9:8]$ , Blue  $LCD\_D[1:0]$ ) are dropped.

Freescale i.MX6 CPU			SMARC-FiMX6 Edge Golden Finger		Net Names (Carrier Board)	Color	24-bit Color Map
Ball	Mode	Pin Name	Pin#	Pin Name			
W24	ALTO	DISP0_DAT23__ IPU1_DISP0_DATA23	S118	LCD_D23 (MSB)	LCD_D23	RED	R7
V24	ALTO	DISP0_DAT22__ IPU1_DISP0_DATA22	S117	LCD_D22	LCD_D22		R6
T20	ALTO	DISP0_DAT21__ IPU1_DISP0_DATA21	S116	LCD_D21	LCD_D21		R5
U22	ALTO	DISP0_DAT20__ IPU1_DISP0_DATA20	S115	LCD_D20	LCD_D20		R4
U23	ALTO	DISP0_DAT19__ IPU1_DISP0_DATA19	S114	LCD_D19	LCD_D19		R3
V25	ALTO	DISP0_DAT18__ IPU1_DISP0_DATA18	S113	LCD_D18	LCD_D18		R2
U24	ALTO	DISP0_DAT17__ IPU1_DISP0_DATA17	S112	LCD_D17	LCD_D17		R1
T21	ALTO	DISP0_DAT16__ IPU1_DISP0_DATA16	S111	LCD_D16 (LSB)	LCD_D16		R0
T22	ALTO	DISP0_DAT15__ IPU1_DISP0_DATA15	S109	LCD_D15 (MSB)	LCD_D15	GREEN	G7
U25	ALTO	DISP0_DAT14__ IPU1_DISP0_DATA14	S108	LCD_D14	LCD_D14		G6
R20	ALTO	DISP0_DAT13__ IPU1_DISP0_DATA13	S107	LCD_D13	LCD_D13		G5
T24	ALTO	DISP0_DAT12__ IPU1_DISP0_DATA12	S106	LCD_D12	LCD_D12		G4
T23	ALTO	DISP0_DAT11__ IPU1_DISP0_DATA11	S105	LCD_D11	LCD_D11		G3
R21	ALTO	DISP0_DAT10__ IPU1_DISP0_DATA10	S104	LCD_D10	LCD_D10		G2
T25	ALTO	DISP0_DAT9__ IPU1_DISP0_DATA09	S103	LCD_D9	LCD_D9		G1
R22	ALTO	DISP0_DAT8__ IPU1_DISP0_DATA08	S102	LCD_D8 (LSB)	LCD_D8		G0

Freescale i.MX6 CPU			SMARC-FiMX6 Edge Golden Finger		Net Names (Carrier Board)	Color	24-bit Color Map
Ball	Mode	Pin Name	Pin#	Pin Name			
R24	ALTO	DISP0_DAT7__ IPU1_DISP0_DATA07	S100	LCD_D7 (MSB)	LCD_D7	BLUE	B7
R23	ALTO	DISP0_DAT6__ IPU1_DISP0_DATA06	S99	LCD_D6	LCD_D6		B6
R25	ALTO	DISP0_DAT5__ IPU1_DISP0_DATA05	S98	LCD_D5	LCD_D5		B5
P20	ALTO	DISP0_DAT4__ IPU1_DISP0_DATA04	S97	LCD_D4	LCD_D4		B4
P21	ALTO	DISP0_DAT3__ IPU1_DISP0_DATA03	S96	LCD_D3	LCD_D3		B3
V23	ALTO	DISP0_DAT2__ IPU1_DISP0_DATA02	S95	LCD_D2	LCD_D2		B2
P22	ALTO	DISP0_DAT1__ IPU1_DISP0_DATA01	S94	LCD_D1	LCD_D1		B1
P24	ALTO	DISP0_DAT0__ IPU1_DISP0_DATA00	S93	LCD_D0 (LSB)	LCD_D0		B0



Freescale i.MX6 CPU			SMARC-FiMX6 Edge Golden Finger		Net Names (Carrier Board)	Color	24-bit Color Map
Ball	Mode	Pin Name	Pin#	Pin Name			
N19	ALT0	DI0_DISP_CLK_ IPU1_DI0_DISP_CLK	S123	LCD_PCK	LCD_PCK		
N21	ALT0	DI0_PIN15_ IPU1_DI0_PIN15	S120	LCD_DE	LCD_DE		
N25	ALT0	DI0_PIN2_ IPU1_DI0_PIN02	S122	LCD_HS	LCD_HS		
N20	ALT0	DI0_PIN3_ IPU1_DI0_PIN03	S121	LCD_VS	LCD_VS		
T5	ALT5	GPIO_0_ GPIO1_I000	S127	LCD_BKLT_EN	LCD_BKLT_EN		
T1	ALT5	GPIO_2_ GPIO1_I002	S133	LCD_VDD_EN	LCD_VDD_EN		
T4	ALT5	GPIO_1_  PWM2_OUT	S141	LCD_BKLT_PWN	LCD_BKLT_PWM		

To use displays which require fewer bits (e.g. 18 or 16 bit displays), simply do not connect the bottom n LSBs for each color, where n is the number of signals that are not required for a specific color. For instance, to connect an 18 bit display, R0, R1, G0, G1, B0 and B1 will remain unused, and R2, G2 and B2 become the LSBs for this configuration.

2.1.9.1 Parallel LCD Data

<b>Edge Golden Finder Signal Name</b>	<b>Direction</b>	<b>Type Tolerance</b>	<b>Description</b>
LCD_D[16:23]	Output	CMOS VDD_IO	8 bit RED color data - 18 bit display implementations leave the two LS bits (D16, D17) not connected
LCD_D[8:15]	Output	CMOS VDD_IO	8 bit GRN color data - 18 bit display implementations leave the two LS bits (D8, D9) not connected
LCD_D[0:7]	Output	CMOS VDD_IO	8 bit BLU color data - 18 bit display implementations leave the two LS bits (D0, D1) not connected
LCD_PCK	Output	CMOS VDD_IO	Pixel clock – display data transitions on the positive clock edge
LCD_DE	Output	CMOS VDD_IO	Display Enable – signal is high during the active display line; low otherwise
LCD_HS	Output	CMOS VDD_IO	Horizontal Sync – high pulse indicates the start of a new horizontal display line
LCD_VS	Output	CMOS VDD_IO	Vertical Synch – high pulse indicates the start of a new display frame

### 2.1.9.2 Parallel LCD Display Support Signals

The signals in the table below support the Parallel LCD and LVDS LCD interfaces (as these are created from the same i.MX6 source).

<i>Edge Golden Finder Signal Name</i>	<i>Direction</i>	<i>Type Tolerance</i>	<i>Description</i>
<i>LCD_VDD_EN</i>	<i>Output</i>	<i>CMOS VDD_IO</i>	<i>High enables panel VDD</i>
<i>LCD_BKLT_EN</i>	<i>Output</i>	<i>CMOS VDD_IO</i>	<i>High enables panel backlight</i>
<i>LCD_BKLT_PWM</i>	<i>Output</i>	<i>CMOS VDD_IO</i>	<i>Display backlight PWM control</i>
<i>I2C_LCD_DAT</i>	<i>Bi-Dir OD</i>	<i>CMOS VDD_IO</i>	<i>I2C data – to read LCD display EDID EEPROMs</i>
<i>I2C_LCD_DK</i>	<i>Output</i>	<i>CMOS VDD_IO</i>	<i>I2C clock – to read LCD display EDID EEPROMs</i>

### **2.1.10 LVDS Interface**

The *SMARC-FiMX6* implements two 18 / 24 bit single channel LVDS output stream (the other LVDS is defined on AFB) for the Primary displays. They can also be configured as an 18 / 24 bit dual channel LVDS directly out of the *SMARC* Module.

The LVDS Display Bridge (LDB) from the Freescale® i.MX6 Cortex A9 processor found on the *SMARC-FiMX6* offers two LVDS channels, with up to 170 Mhz pixel clock. Each channel consists of one clock pair and four data pairs. The LDB supports the flow of synchronous RGB data from the Image Processing Unit (IPU) to external display devices through LVDS interface.

The LVDS interface also supports various resolutions but with stipulated maximum data rates. The data rates supported are as follows:

For single channel output: Up to 85 MHz per interface (e.g 1366x768 @ 60 Hz + 35 % blanking).

For dual channel output: Up to 170 MHz pixel clock (e.g 1600x1200 @ 60Hz + 35 % blanking)

The LVDS ports support the following configurations:

- One single channel output
- One dual channel output: single input split to two output channels
- Two identical outputs: single input sent to both output channels
- Two independent outputs: two inputs sent, each to a different output channel

#### **Note:**

The LVDS interface can be used either as a single channel or as a dual channel. It is also possible to use the LVDS interface as two independent single LVDS channels if the iMX.6 processor on *SMARC* module has two IPUs. To do this, it is recommended to configure the LVDS display in the bootloader. (See Embedian developer guides.)

Three independent displays are possible when connected as two single LVDS channel and one HDMI interface.

The following figure shows the LVDS LCD block diagram.

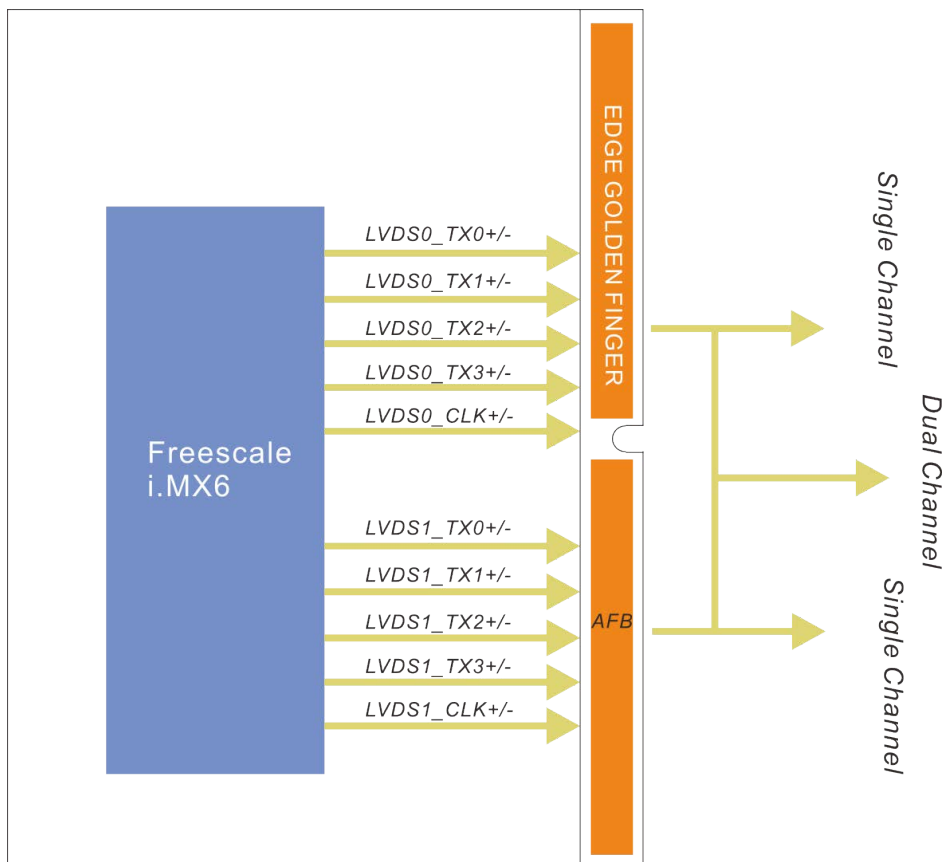

**Figure 3: SMARC-FiMX6 LVDS LCD Diagram**

Freescale i.MX6 CPU			SMARC-FiMX6 Edge Golden Finger		Net Names	Note
Ball	Mode	Pin Name	Pin#	Pin Name		
<b>LVDS Channel 0</b>						
U1	ALT0	LVDS0_TX0_P	S125	LVDS0+	LVDS0_D0+	LVDS0 LCD data channel differential pairs 1
U2	ALT0	LVDS0_TX0_N	S126	LVDS0-	LVDS0_D0-	
U3	ALT0	LVDS0_TX1_P	S128	LVDS1+	LVDS0_D1+	LVDS0 LCD data channel differential pairs 2
U4	ALT0	LVDS0_TX1_N	S129	LVDS1-	LVDS0_D1-	
V1	ALT0	LVDS0_TX2_P	S131	LVDS2+	LVDS0_D2+	LVDS0 LCD data channel differential pairs 3
V2	ALT0	LVDS0_TX2_N	S132	LVDS2-	LVDS0_D2-	
W1	ALT0	LVDS0_TX3_P	S137	LVDS3+	LVDS0_D3+	LVDS0 LCD data channel differential pairs 4
W2	ALT0	LVDS0_TX3_N	S138	LVDS3-	LVDS0_D3-	
V3	ALT0	LVDS0_CLK_P	S134	LVDS_CK+	LVDS0_CK+	LVDS0 LCD differential clock pairs
V4	ALT0	LVDS0_CLK_N	S135	LVDS_CK-	LVDS0_CK-	
<b>LVDS Channel 1</b>						
Y2	ALT0	LVDS1_TX0_P	S62	AFB_DIFF0+	AFB_DIFF0+	LVDS1 LCD data channel differential pairs 1
Y1	ALT0	LVDS1_TX0_N	S63	AFB_DIFF0-	AFB_DIFF0-	
AA1	ALT0	LVDS1_TX1_P	S65	AFB_DIFF1+	AFB_DIFF1+	LVDS1 LCD data channel differential pairs 2
AA2	ALT0	LVDS1_TX1_N	S66	AFB_DIFF1-	AFB_DIFF1-	
AB2	ALT0	LVDS1_TX2_P	S68	AFB_DIFF2+	AFB_DIFF2+	LVDS1 LCD data channel differential pairs 3
AB1	ALT0	LVDS1_TX2_N	S69	AFB_DIFF2-	AFB_DIFF2-	
AA4	ALT0	LVDS1_TX3_P	S74	AFB_DIFF4+	AFB_DIFF4+	LVDS1 LCD data channel differential pairs 4
AA3	ALT0	LVDS1_TX3_N	S75	AFB_DIFF4-	AFB_DIFF4-	
Y4	ALT0	LVDS1_CLK_P	S71	AFB_DIFF3+	AFB_DIFF3+	LVDS1 LCD differential clock pairs
Y3	ALT0	LVDS1_CLK_N	S72	AFB_DIFF3-	AFB_DIFF3-	

A 24 bit dual channel LVDS implementation comprises 10 differential pairs: 4 pairs for odd pixel and control data; 1 pair for the LVDS clock for the odd data; 4 pairs for the even pixel data and control data, and 1 pair for the even LVDS clock. To use the dual channel LVDS mode, you need a display supporting the dual channel LVDS mode in order to receive odd and even pixel data.

### **2.1.11. HDMI Interface**

High-Definition Multimedia Interface (HDMI) is a licensable compact audio/video connector interface for transmitting uncompressed digital streams. HDMI encodes the video data into TMDS for digital transmission and is backward-compatible with the single-link Digital Visual Interface (DVI) carrying digital video.

The *SMARC-FiMX6* provides *HDMI* connection directly from the *Freescale® i.MX6* processor. Video data is provided through three differential TMDS data pairs (*HDMI\_D0±* to *HDMI\_D2±*) and one differential clock pair (*HDMI\_CLK±*). In addition, the *SMARC-FiMX6* includes one standard I2C interface (*HDMI\_CTRL\_SDA* and *HDMI\_CTRL\_SCL*) for configuring and testing the HDMI 3D Tx PHY and a pin (*HDMI\_HPD*) for HDMI hot plug detection support.

The following figure shows the HDMI block diagram.

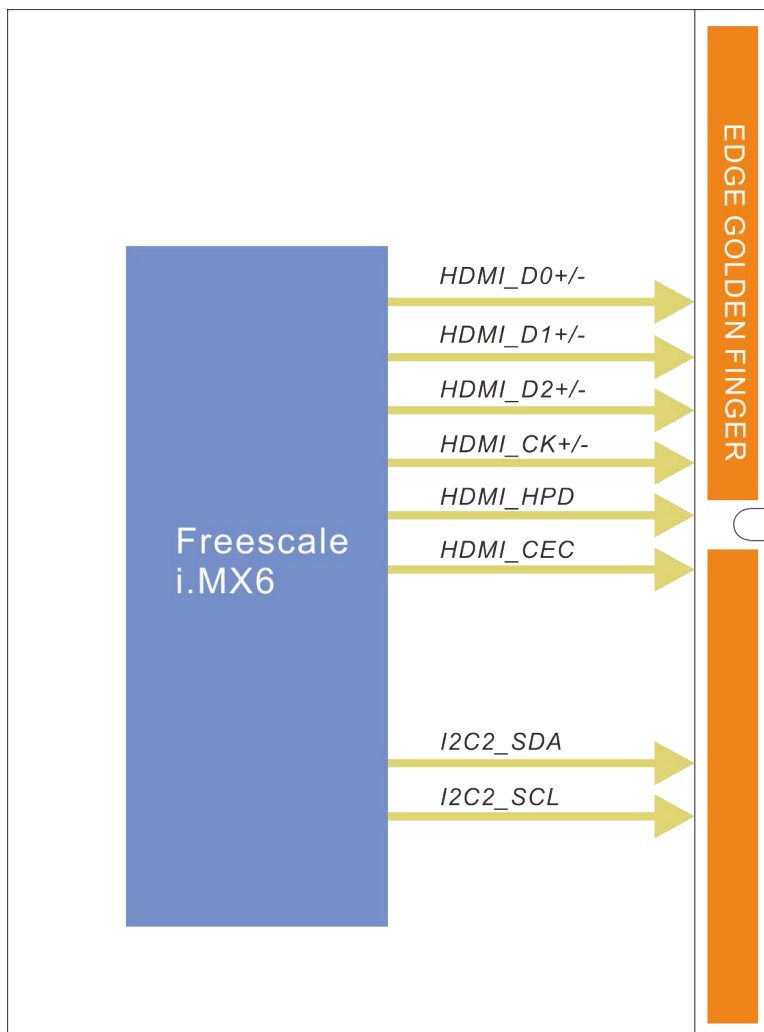

**Figure 4: SMARC-FiMX6 HDMI Diagram**



Freescale i.MX6 CPU			SMARC-FiMX6 Edge Golden Finger		Net Names	Note
Ball	Mode	Pin Name	Pin#	Pin Name		
<b>HDMI</b>						
K5	N/A	HDMI_D0M	P99	HDMI_D0-	HDMI_D0-	TMDS / HDMI data differential pair 0
K6	N/A	HDMI_D0P	P98	HDMI_D0+	HDMI_D0+	
J3	N/A	HDMI_D1M	P96	HDMI_D1-	HDMI_D1-	TMDS / HDMI data differential pair 1
J4	N/A	HDMI_D1P	P95	HDMI_D1+	HDMI_D1+	
K3	N/A	HDMI_D2M	P93	HDMI_D2-	HDMI_D2-	TMDS / HDMI data differential pair 2
K4	N/A	HDMI_D2P	P92	HDMI_D2+	HDMI_D2+	
J5	N/A	HDMI_CLKM	P102	HDMI_CK-	HDMI_CK-	HDMI differential clock output pair
J6	N/A	HDMI_CLKP	P101	HDMI_CK+	HDMI_CK+	
K1	N/A	HDMI_HPD	P104	HDMI_HPD	HDMI_HPD	HDMI Hot Plug Detect input
K2	N/A	HDMI_DDCCEC	P107	HDMI_CEC	HDMI_CEC	HDMI Consumer Electronics Control 1 – wire peripheral control interface
<b>I2C Dedicate for HDMI</b>						
T7	ALT4	KEY_ROW3__ I2C2_SDA	P106	HDMI_CTRL_DAT	HDMI_CTRL_DAT	I2C Data
U5	ALT4	KEY_COL3__ I2C2_SCL	P105	HDMI_CTRL_CLK	HDMI_CTRL_CLK	I2C Clock

### 2.1.11.1 HDMI Signals

The table below shows the HDMI related signals.

Edge Golden Finder Signal Name	Direction	Type Tolerance	Description
HDMI_D[0:2]+ HDMI_D[0:2]-	Output	TDMS	TMDS / HDMI data differential pairs
HDMI_CK+ HDMI_CK-	Output	TDMS	HDMI differential clock output pair
HDMI_HPD	Input	CMOS VDD_IO	HDMI Hot Plug Detect input
HDMI_CTRL_DAT	Bi-Dir OD	CMOS VDD_IO	I2C data line dedicated to HDMI
HDMI_CTRL_CK	Bi-Dir OD	CMOS VDD_IO	I2C clock line dedicated to HDMI
HDMI_CEC	Bi-Dir	CMOS VDD_IO	HDMI Consumer Electronics Control 1 – wire peripheral control interface

HDMI displays uses 5V I2C signaling. The Module *HDMI\_CTRL\_DAT* and *HDMI\_CTRL\_CK* signals need to be level translated on the Carrier from the Module *VDD\_IO* level (3.3V or 1.8V). A similar consideration applies to the *HDMI\_HPD* signal. There are a number of single chip devices on the market that perform ESD protection and control signal level shifting for HDMI interfaces. The Texas Instruments *TPD12S016* is one such device.

### 2.1.12 USB Interface

The Embedian *SMARC-FiMX6* module supports two USB ports (*USB 0:1*). Per the *SMARC* specification, the module supports a USB “On-The-Go” (OTG) port capable of functioning either as a client or host device, on the *SMARC* USB0 port. The *SMARC-FiMX6* module also supports one additional USB2.0 host ports, on *SMARC* USB1.

The following figure shows the USB0 and USB1 block diagram.

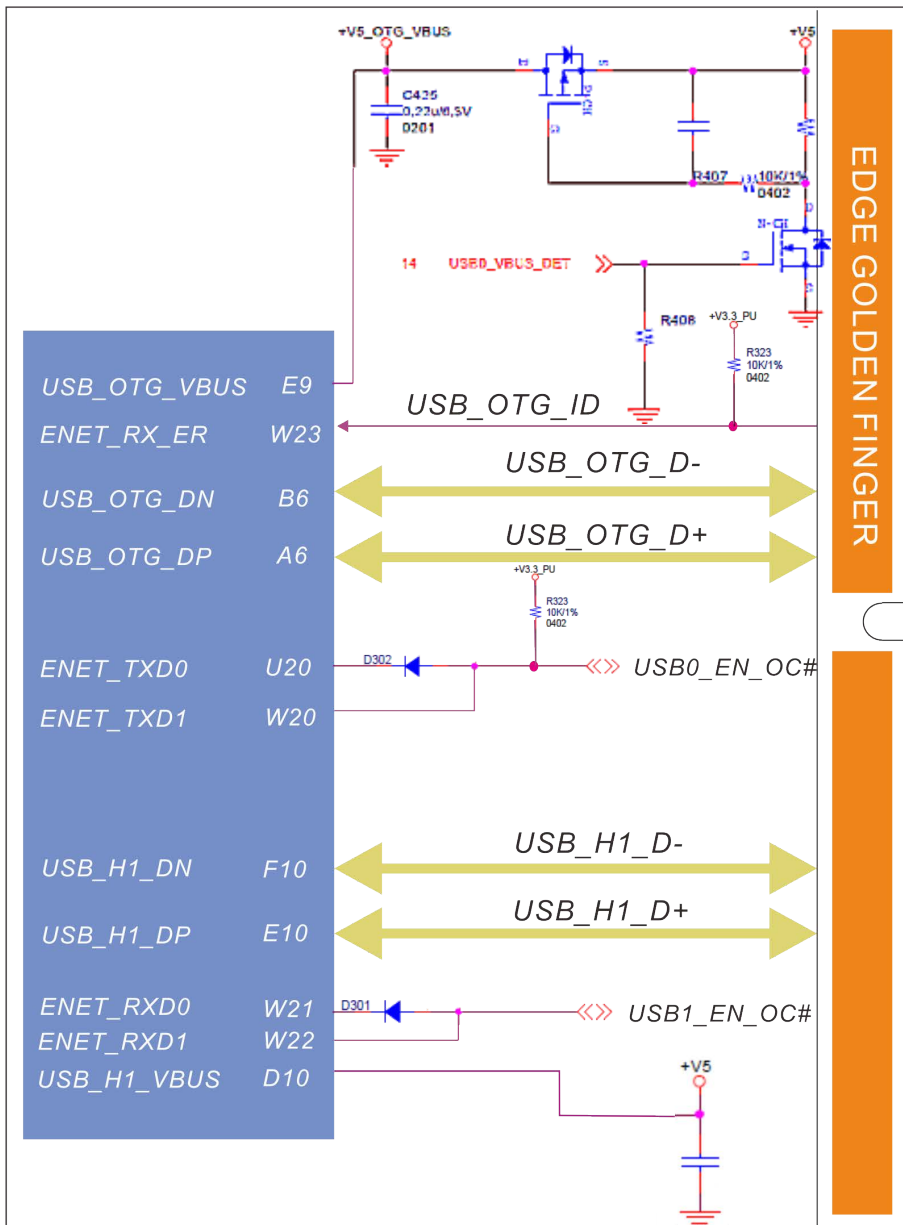

Figure 5. USB0 and USB1 Block Diagram

## Embedian, Inc.

USB interface signals are exposed on the *SMARC-FiMX6* edge connector as shown below:

Freescale i.MX6 CPU			SMARC-FiMX6 Edge Golden Finger		Net Names	Note
Ball	Mode	Pin Name	Pin#	Pin Name		
<b>USB0 Port (OTG)</b>						
A6		USB_OTG_DP	P60	USB0+	USB0+	USB0 port data pair
B6		USB_OTG_DN	P61	USB0-	USB0-	
U20	ALT5	ENET_TXD0__ GPIO1_I030	P62	USB0_EN_OC#	USB0_EN_OC#	USB Port0 power enable/over current indication signal
W20	ALT5	ENET_TXD1__ GPIO1_I029				
E9		Turn on USB_OTG_VBUS	P63	USB0_VBUS_DET	USB0_VBUS_DET	USB host power detection, when this port is used as a device.
W23	ALT0	ENET_RX_ER__ USB_OTG_ID	P64	USB0_OTG_ID	USB0_OTG_ID	USB OTG ID input, active high
<b>USB1 Port (Host 2.0)</b>						
E10		USB_H1_DP	P65	USB1+	USB1+	USB1 port data pair
F10		USB_H1_DN	P66	USB1-	USB1-	
W21	ALT5	ENET_RXD0__ GPIO1_I027	P67	USB1_EN_OC#	USB1_EN_OC#	USB Port0 power enable/over current indication signal
W22	ALT5	ENET_RXD1__ GPIO1_I026				

**2.1.12.1 USB0 Signals**

The table below shows the USB0 related signals.

<i>Edge Golden Finder Signal Name</i>	<i>Direction</i>	<i>Type Tolerance</i>	<i>Description</i>
<i>USB0+ USB0-</i>	<i>Bi-Dir</i>	<i>USB</i>	<i>Differential USB0 Data Pair</i>
<i>USB0_EN_OC#</i>	<i>Bi-Dir OD</i>	<i>CMOS 3.3V</i>	<i>Pulled low by Module OD driver to disable USB0 power.  Pulled low by Carrier OD driver to indicate over-current situation.  A 10k pull-up is present on the Module to a 3.3V rail. The pull-up rail may be switched off to conserve power if the USB port is not in use. Further details may be found in Section 2.1.12.3 USBx_EN_OC# Discussion below.</i>
<i>USB0_VBUS_DET</i>	<i>Input</i>	<i>USB VBUS 5V</i>	<i>USB host power detection, when this port is used as a device.</i>
<i>USB0_OTG_ID</i>	<i>Input</i>	<i>CMOS 3.3V</i>	<i>USB OTG ID input, active high.</i>

### 2.1.12.2 USB1 Signals

USB1 port is a USB 2.0 host port. The table below shows the USB1 related signals.

<i>Edge Golden Finder Signal Name</i>	<i>Direction</i>	<i>Type Tolerance</i>	<i>Description</i>
USB1+ USB1-	Bi-Dir	USB	Differential USB1 Data Pair
USB1_EN_OC#	Bi-Dir OD	CMOS 3.3V	<p>Pulled low by Module OD driver to disable USB0 power.</p> <p>Pulled low by Carrier OD driver to indicate over-current situation.</p> <p>A 10k pull-up is present on the Module to a 3.3V rail. The pull-up rail may be switched off to conserve power if the USB port is not in use. Further details may be found in Section 2.1.12.3 USBx_EN_OC# Discussion below.</p>

### 2.1.12.3 USBx\_EN\_OC# Discussion

The Module *USBx\_EN\_OC#* pins (where 'x' is 0 or 1 for use with USB0 or USB1) are multi-function Module pins, with a 10k pull-up to a 3.3V rail on the Module, an OD driver on the Module, and, if the OC# (over-current) monitoring function is implemented on the Carrier, an OD driver on the Carrier. The use is as follows:

- 1) On the Carrier board, for external plug-in USB peripherals (USB memory sticks, cameras, keyboards, mice, etc.) USB power distribution is typically handled by USB power switches such as the Texas Instruments TPS2052B or the *Micrel MIC2026-1* or similar devices. The Carrier implementation is more straightforward if the Carrier USB power switches have active-high power enables and active low open drain *OC#* outputs (as the TI and Micrel devices referenced do). The USB power switch Enable and *OC#* pins for a given USB channel are tied together on the Carrier. The USB power switch enable pin must function with a low input current. The TI and Micrel devices referenced above require 1 microampere or less, at a 3.3V enable voltage level.
- 2) The Module drives *USBx\_EN\_OC#* low to disable the power delivery to the *USBx* device.
- 3) The Module floats *USBx\_EN\_OC#* to enable power delivery. The line is

pulled to 3.3V by the Module pull-up, enabling the Carrier board USB power switch.

- 4) If there is a USB over-current condition, the Carrier board USB power switch drives the *USBx\_EN\_OC#* line low. This removes the over-current condition (by disabling the USB switch enable input), and allows Module software to detect the over-current condition.
- 5) The Module software should look for a falling edge interrupt on *USBx\_EN\_OC#*, while the port is enabled, to detect the *OC#* condition. The *OC#* condition will not last long, as the USB power switch is disabled when the switch IC detects the *OC#* condition.
- 6) If the USB power to the port is disabled (*USBx\_EN\_OC#* is driven low by the Module) then the Module software is aware that the port is disabled, and the low input value on the port does not indicate an over-current condition (because the port power is disabled).

Carrier Board USB peripherals that are not removable often do not make use of USB power switches with current limiting and over-current detection. It is usually deemed un-necessary for non-removable devices. In these cases, the *USBx\_EN\_OC#* pins may be left unused, or they may be used as *USBx* power enables, without making use of the over-current detect Module input feature.

## *Embedian, Inc.*

The *SMARC-FiMX6* Module USB power enable and over current indication logic implementation is shown in the following block diagram. There are 10k pull-up resistors on the Module on the *SMARC USBx\_EN\_OC#* lines. Outputs driving the *USBx\_EN\_OC#* lines are open-drain. The Carrier board USB power switch, if present, is enabled by *USBx\_EN\_OC#* after a device connection is detected on the DP/DM lines.



The Enable pin on the Carrier board USB power switch must be active – high and the Over-Current pin (OC#) must be open drain, active low (these are commonly available). No pull-up is required on the USB power switch Enable or OC# line on carrier board; they are tied together on the Carrier and fed to the Module *USBx\_EN\_OC#* pin.

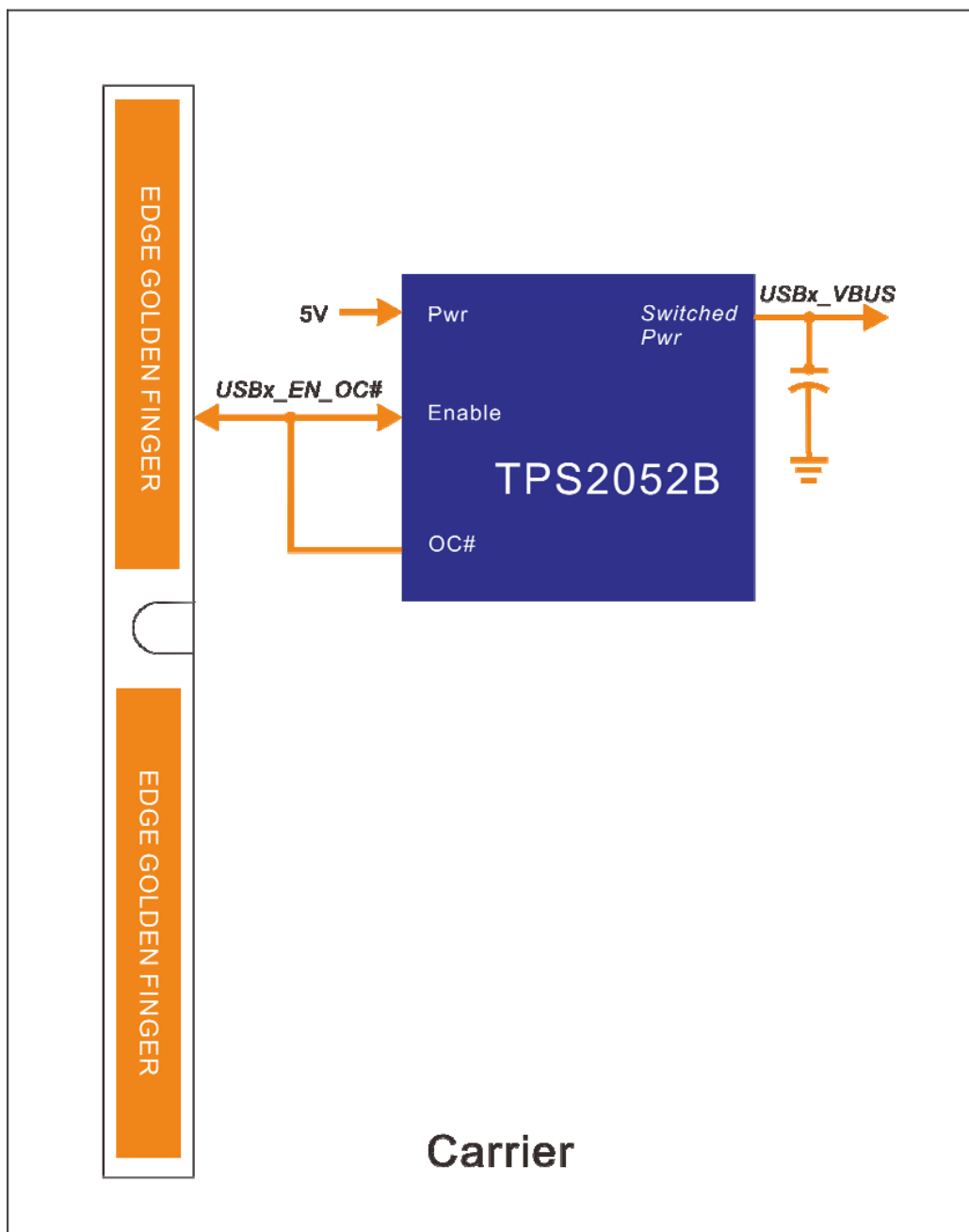

**Figure 6. USB Power Distribution Implementation on Carrier**

### **2.1.13. Gigabit Ethernet Controller (10/100/1000Mbps) Interface**

The *SMARC-FiMX6* module supports one Gigabit Ethernet (10/100/1000Mbps) interfaces. The Gigabit Ethernet controller interfaces are accomplished by using the low-power Qualcomm Atheros AR8035 physical layer (PHY) transceiver with variable I/O voltage that is compliant with the IEEE 802.3-2005 standards. The AR8035 supports communication with an Ethernet MAC via a standard RGMII interface.

The Ethernet interface consists of 4 pairs of low voltage differential pair signals designated from *GBE0\_MDI0±* to *GBE0\_MDI3±* plus control signals for link activity indicators. These signals can be used to connect to a 10/100/1000 BaseT RJ45 connector with integrated or external isolation magnetics on the carrier board.

This is diagrammed below.

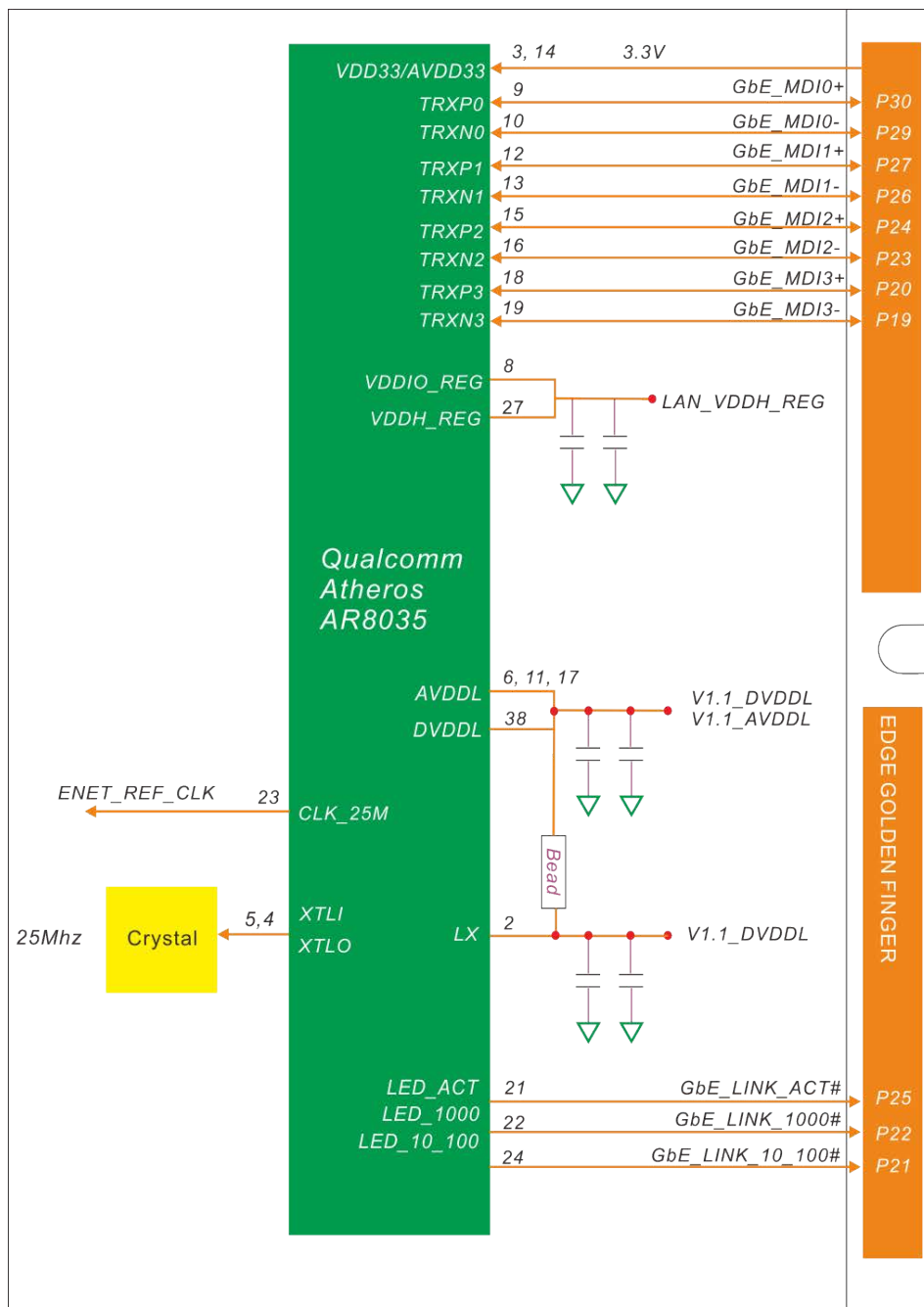

Figure 7: Gigabit Ethernet Connection from i.MX6 to Qualcomm Atheros AR8035

## Embedian, Inc.

i.MX6 processor and Qualcomm Atheros AR8035 implementation is shown in the following table:

Freescale i.MX6 CPU			Qualcomm AR8035		Net Names	Note
Ball	Mode	Pin Name	Pin#	Pin Name		
<b>Gigabit LAN</b>						
V23	ALT1	ENET_MDIO__ ENET_MDIO	39	MDIO	ENET_MDIO	Serial Management Interface data input/output
V20	ALT1	ENET_MDC__ ENET_MDC	40	MDC	ENET_MDC	Serial Management Interface clock
C24	ALT1	RGMII_RD0__ RGMII_RD0	29	RXD0	RMII_RD0	Bit 0 of the 4 data bits that are sent by the transceiver on the receive path.
B23	ALT1	RGMII_RD1__ RGMII_RD1	28	RXD1	RMII_RD1	Bit 1 of the 4 data bits that are sent by the transceiver on the receive path.
B24	ALT1	RGMII_RD2__ RGMII_RD2	26	RXD2	RMII1_RD2	Bit 2 of the 4 data bits that are sent by the transceiver on the receive path.
D23	ALT1	RGMII_RD3__ RGMII_RD3	25	RXD3	RGMII_RD3	Bit 3 of the 4 data bits that are sent by the transceiver on the receive path.
B25	ALT1	RGMII_RXC__ RGMII_RXC	31	RX_CLK	RGMII_RXC	Reference clock
D22	ALT1	RGMII_RX_CTL__ RGMII_RX_CTL	30	RX_DV	RGMII_RX_CTL	Indicates both the receive data valid (RXDV) and receive error (RXER) functions per the RGMII specification.

Freescale i.MX6 CPU			Qualcomm AR8035		Net Names	Note
Ball	Mode	Pin Name	Pin#	Pin Name		
<b>Gigabit LAN</b>						
C23	ALT1	RGMII_TX_CTL__ RGMII_TX_CTL	32	TX_EN	RGMII_TX_CT L	Indicates that valid transmission data is present on TXD[3:0].
C22	ALT1	RGMII_TD0__ RGMII_TD0	34	TXD0	RGMII_TD0	The MAC transmits data to the transceiver using this signal.
F20	ALT1	RGMII_TD1__ RGMII_TD1	35	TXD1	RGMII_TD1	The MAC transmits data to the transceiver using this signal.
E21	ALT1	RGMII_TD2__ RGMII_TD2	36	TXD2	RGMII_TD2	The MAC transmits data to the transceiver using this signal.
A24	ALT1	RGMII_TD2__ RGMII_TD2	37	TXD3	RGMII_TD3	The MAC transmits data to the transceiver using this signal.
D21	ALT1	RGMII_TXC__ RGMII_TXC	33	GTX_CLK	RGMII_TXC	Used to latch data from the MAC into the PHY.  1000BASE-T: 125MHz  100BASE-TX: 25MHz  10BASE-T: 2.5MHz

## Embedian, Inc.

The path from AR8035 to the golden finger edge connector is show in the following table.

Qualcomm AR8035		Golden Finger Edge Connector		Net Names	Note
Pin	Pin Name	Pin#	Pin Name		
<i>AR8035 PHY</i>					
9	TRXP0	P30	GbE_MDI0+	GBE_MDI0+	Differential Transmit/Receive Positive Channel 0
10	TRXN0	P29	GbE_MDI0-	GBE_MDI0-	Differential Transmit/Receive Negative Channel 0
		P28	GbE_CTREF	GBE_CTREF	Center tap reference voltage
12	TRXP1	P27	GbE_MDI1+	GBE_MDI1+	Differential Transmit/Receive Positive Channel 1
13	TRXN1	P26	GbE_MDI1-	GBE_MDI1-	Differential Transmit/Receive Negative Channel 1
15	TRXP2	P24	GbE_MDI2+	GBE_MDI2+	Differential Transmit/Receive Positive Channel 2
16	TRXN2	P23	GbE_MDI2-	GBE_MDI2-	Differential Transmit/Receive Negative Channel 2
18	TRXP3	P20	GbE_MDI3+	GBE_MDI3+	Differential Transmit/Receive Positive Channel 3
19	TRXN3	P19	GbE_MDI3-	GBE_MDI3-	Differential Transmit/Receive Negative Channel 3

Qualcomm AR8035		Golden Finger Edge Connector		Net Names	Note
Pin	Pin Name	Pin#	Pin Name		
<i>AR8035 PHY</i>					
21	LED_ACT	P25	GbE_LINK_ACT#	GBE_LINK_ACT#	<p>Link / Activity Indication LED</p> <p>Driven low on Link (10, 100 or 1000 mbps)</p> <p>Blinks on Activity</p> <p>Could be able to sink 24mA or more Carrier LED current</p>
24	LED_10_100	P21	GbE_LINK100#	GBE_LINK100#	<p>Link Speed Indication LED for 100Mbps</p> <p>Could be able to sink 24mA or more Carrier LED current</p>
22	LED_1000	P22	GbE_LINK1000#	GBE_LINK1000#	<p>Link Speed Indication LED for 1000Mbps</p> <p>Could be able to sink 24mA or more Carrier LED current</p>

**Note:** The theoretical maximum performance of 1 Gbps Ethernet is limited to 470 Mbps (total for Tx and Rx) due to internal bus throughput limitations. The actual measured performance in optimized environment is up to 400 Mbps. For more information, consult Freescale’s Errata *ERR004512*.

### 2.1.13.1. Gigabit LAN Signals

The table below shows the Gigabit LAN related signals.

<b>Edge Golden Finder Signal Name</b>	<b>Direction</b>	<b>Type Tolerance</b>	<b>Description</b>
GBE_MDI0+ GBE_MDI0-	Bi-Dir	GBE_MDI	Bi-directional transmit/receive pair 0 to magnetics (Media Dependent Interface)
GBE_MDI1+ GBE_MDI1-	Bi-Dir	GBE_MDI	Bi-directional transmit/receive pair 1 to magnetics (Media Dependent Interface)
GBE_MDI2+ GBE_MDI2-	Bi-Dir	GBE_MDI	Bi-directional transmit/receive pair 2 to magnetics (Media Dependent Interface)
GBE_MDI3+ GBE_MDI3-	Bi-Dir	GBE_MDI	Bi-directional transmit/receive pair 3 to magnetics (Media Dependent Interface)
GBE_100#	Output OD	CMOS 3.3V	Link Speed Indication LED for 100Mbps Could be able to sink 24mA or more Carrier LED current
GBE_1000#	Output OD	CMOS 3.3V	Link Speed Indication LED for 1000Mbps Could be able to sink 24mA or more Carrier LED current
GBE_LINK_ACK#	Output OD	CMOS 3.3V	Link / Activity Indication LED Driven low on Link (10, 100 or 1000 mbps) Blinks on Activity Could be able to sink 24mA or more Carrier LED current
GBE_CTREF	Output	Reference Voltage	Center-Tap reference voltage for GBE0 Carrier board Ethernet magnetic (not required by the Module GBE PHY)



*Embedian, Inc.*

**2.1.13.2. Suggested Magnetics**

Listed below are suggested magnetics.

For normal temperature (0°C ~70°C) products.

<i>Vendor</i>	<i>P/N</i>	<i>Package</i>	<i>Cores</i>	<i>Temp</i>	<i>Configuration</i>
<i>Halo</i>	<i>HFJ11-1G02E</i>	<i>Integrated RJ45</i>	<i>8</i>	<i>0°C~70°C</i>	<i>HP Auto-MDIX</i>
<i>UDE</i>	<i>RB1-BA6BT9WA</i>	<i>Integrated RJ45</i>	<i>8</i>	<i>-40°C~85°C</i>	<i>HP Auto-MDIX</i>
<i>Halo</i>	<i>TG1G-S002NZRL</i>	<i>24-pin SOIC-W</i>	<i>8</i>	<i>0°C~70°C</i>	<i>HP Auto-MDIX</i>

For industrial temperature (-40°C ~85°C) products.

<i>Vendor</i>	<i>P/N</i>	<i>Package</i>	<i>Cores</i>	<i>Temp</i>	<i>Configuration</i>
<i>UDE</i>	<i>RB1-BA6BT9WA</i>	<i>Integrated RJ45</i>	<i>8</i>	<i>-40°C~85°C</i>	<i>HP Auto-MDIX</i>
<i>Halo</i>	<i>TG1G-E012NZRL</i>	<i>24-pin SOIC-W</i>	<i>8</i>	<i>-40°C~85°C</i>	<i>HP Auto-MDIX</i>

### 2.1.14. PCIe Interface

The *SMARC-FiMX6* offers one PCI Express lane. The PCIe signals are routed from the Freescale® i.MX6 processor to the PCI Express port A of the *SMARC-FiMX6* edge finger. These signals support PCI Express Gen. 2.0 interfaces at 5 Gb/s and are backward compatible to Gen. 1.1 interfaces at 2.5 Gb/s. Only x1 PCI Express link configuration is possible.

The following figure shows the PCIe port A block diagram.

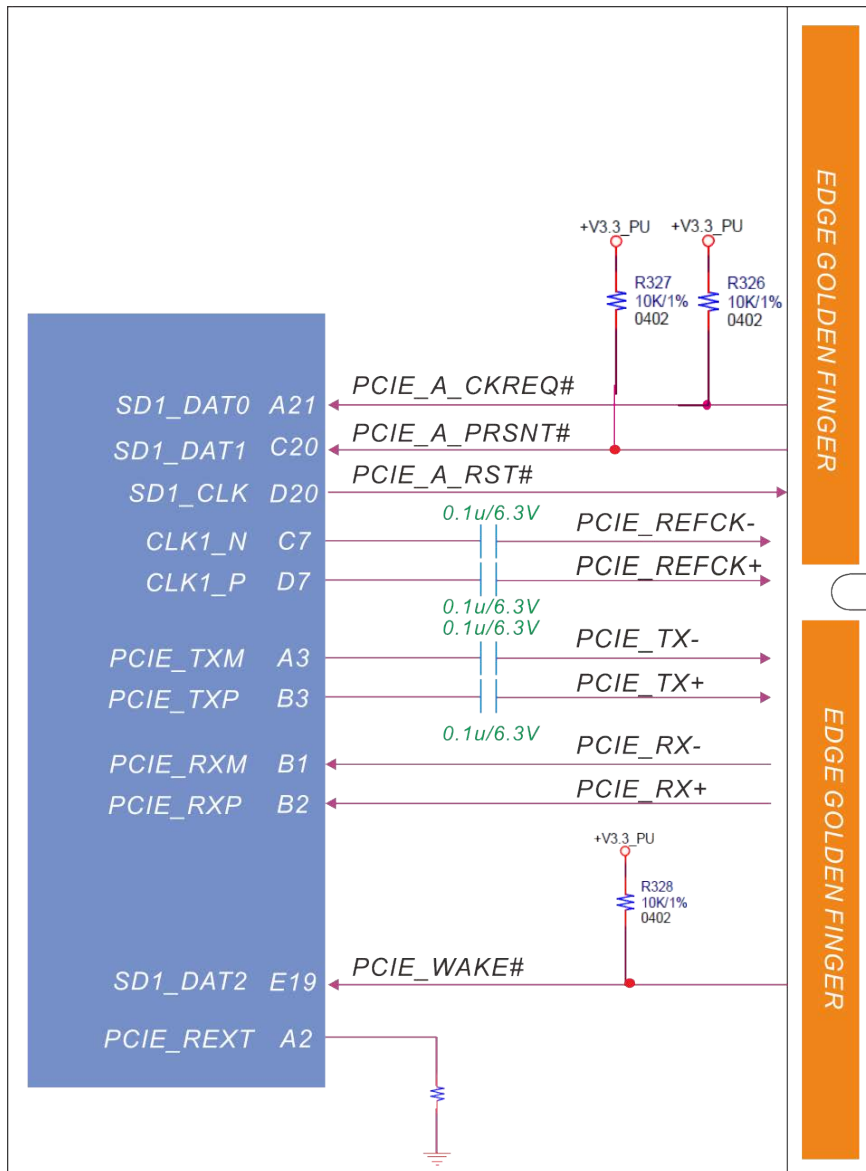

**Figure 8. PCI Express Block Diagram**

## Embedian, Inc.

PCI Express interface signals are exposed on the *SMARC-FiMX6* edge connector as shown below:

Freescale i.MX6 CPU			SMARC-FiMX6 Edge Golden Finger		Net Names	Note
Ball	Mode	Pin Name	Pin#	Pin Name		
<i>PCI Express Port A</i>						
D20	ALT5	SD1_CLK__ GPIO1_I020	P75	PCIE_A_RST#	PCIE_A_RST#	Reset Signal for external devices.
A21	ALT5	SD1_DAT0__ GPIO1_I016	P78	PCIE_A_CKREQ#	PCIE_A_CKREQ#	PCIe Port A clock request input
D7		CLK1_P	P83	PCIE_A_REFCK+	PCIE_A_REFCK+	Differential PCI Express Reference Clock Signals for Lanes A
C7		CLK1_N	P84	PCIE_A_REFCK-	PCIE_A_REFCK-	
B2		PCIE_RXP	P86	PCIE_A_RX+	PCIE_A_RX+	Differential PCIe Link A receive data pair 0
B1		PCIE_RXM	P87	PCIE_A_RX-	PCIE_A_RX-	
B3		PCIE_TXP	P89	PCIE_A_TX+	PCIE_A_TX+	Differential PCIe Link A transmit data pair 0
A3		PCIE_TXM	P90	PCIE_A_TX-	PCIE_A_TX-	
C20	ALT5	SD1_DAT1__ GPIO1_I017	P74	PCIE_A_PRSNT#	PCIE_A_PRSNT#	PCIe Port A present input
E19	ALT5	SD1_DAT2__ GPIO1_I019	S146	PCIE_WAKE#	PCIE_WAKE#	PCI Express Wake Event: Sideband wake signal asserted by components requesting wakeup.

### 2.1.14.1. PCIe\_Link A Signals

The table below shows the *PCIe\_Link A* related signals.

<i>Edge Golden Finder Signal Name</i>	<i>Direction</i>	<i>Type Tolerance</i>	<i>Description</i>
<i>PCIE_A_TX+ PCIE_A_TX-</i>	<i>Output</i>	<i>LVDS PCIe</i>	<i>Differential PCIe Link A transmit data pair 0 Series coupling caps is on the Module Caps is 0402 package 0.1uF</i>
<i>PCIE_A_RX+ PCIE_A_RX-</i>	<i>Input</i>	<i>LVDS PCIe</i>	<i>Differential PCIe Link A receive data pair 0 No coupling caps on Module</i>
<i>PCIE_A_REFCK+ PCIE_A_REFCK-</i>	<i>Output</i>	<i>LVDS PCIe</i>	<i>Differential PCIe Link A reference clock output DC coupled</i>
<i>PCIE_A_CKREQ#</i>	<i>Input</i>	<i>CMOS 3.3V</i>	<i>PCIe Port A clock request input Pulled up or terminated on Module</i>
<i>PCIE_A_RST#</i>	<i>Output</i>	<i>CMOS 3.3V</i>	<i>PCIe Port A reset output</i>
<i>PCIE_A_PRSENT#</i>	<i>Input</i>	<i>CMOS 3.3V</i>	<i>PCIe Port A present input Pulled up or terminated on Module</i>

### 2.1.14.2. PCIe Wake Signals

The table below shows the *PCIe Wake* signal.

<i>Edge Golden Finder Signal Name</i>	<i>Direction</i>	<i>Type Tolerance</i>	<i>Description</i>
<i>PCIE_WAKE#</i>	<i>Input</i>	<i>CMOS 3.3V</i>	<i>PCIe wake up interrupt to host – common to PCIe links A, B, C – pulled up or terminated on Module</i>

### **2.1.15. SATA Interface**

The Freescale® i.MX6 Cortex A9 processor on the *SMARC-FiMX6* supports one SATA port. The supported signals are coupled with 10nF capacitors and then routed to *SMARC-FiMX6* edge finger per defined in *SMARC* specification. The *SMARC-FiMX6* offers this SATA port on the MXM connector. This port supports SATA I (1.5Gbps) and SATA II (3Gbps) and is compliant with SATA specification 3.0, AHCI specification 1.3 and Advanced Microcontroller Bus Architecture (AMBA) specification 2.0.

**Note:** SATA interface is only supported on *SMARC-FiMX6* quad and dual core variants. Solo core and dual lite variants do not support SATA.

The following figure shows the SATA port A block diagram.

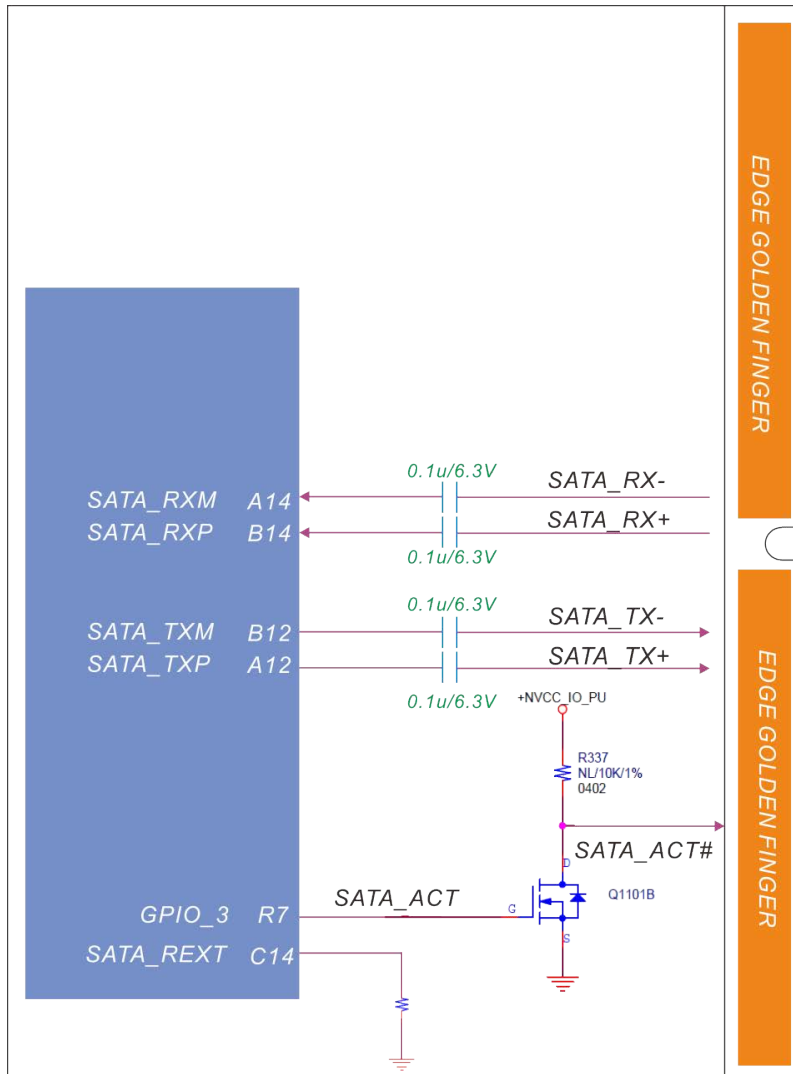

Figure 9. SATA Block Diagram

**Embedian, Inc.**

SATA interface signals are exposed on the *SMARC-FiMX6* edge connector as shown below:

<i>Freescale i.MX6 CPU</i>			<i>SMARC-FiMX6 Edge Golden Finger</i>		<i>Net Names</i>	<i>Note</i>
<i>Ball</i>	<i>Mode</i>	<i>Pin Name</i>	<i>Pin#</i>	<i>Pin Name</i>		
<b>SATA</b>						
<i>B14</i>		<i>SATA_RXP</i>	<i>P51</i>	<i>SATA_RX+</i>	<i>SATA_RX+</i>	<i>Receive Input differential pair.</i>
<i>A14</i>		<i>SATA_RXM</i>	<i>P52</i>	<i>SATA_RX-</i>	<i>SATA_RX-</i>	
<i>B12</i>		<i>SATA_TXM</i>	<i>P49</i>	<i>SATA_TX-</i>	<i>SATA_TX-</i>	<i>Transmit Output differential pair.</i>
<i>A12</i>		<i>SATA_TXP</i>	<i>P48</i>	<i>SATA_TX+</i>	<i>SATA_TX+</i>	
<i>R7</i>	<i>ALT5</i>	<i>GPIO_3__ GPIO1_I003</i>	<i>S54</i>	<i>SATA_ACT#</i>	<i>SATA_ACT#</i>	<i>Serial ATA Led. Open collector output pin driven during SATA command activity.</i>

### **2.1.15.1. SATA Signals**

The table below shows the SATA related signals.

<b>Edge Golden Finder Signal Name</b>	<b>Direction</b>	<b>Type Tolerance</b>	<b>Description</b>
SATA_TX+ SATA_TX-	Output	SATA	Differential SATA 0 transmit data Pair Series coupling caps is on the Module Caps is 0402 package 0.1uF
SATA_RX+ SATA_RX-	Input	SATA	Differential SATA 0 transmit data Series coupling caps is on the Module Caps is 0402 package 0.1uF
SATA_ACT#	Output OD	CMOS 3.3V	Active low SATA activity indicator It is able to sink 24mA or more Carrier LED current



### **2.1.16. MIPI/CMOS Serial Camera Interface**

The *Freescale® i.MX6* Image Processing Unit (*IPU*) provides connectivity to cameras via the *MIPI/CSI-2* transmitter and maintains image manipulation and processing with adequate synchronization and control. The Camera Serial Interface (*CSI*) controls the camera port and provides interface to an image sensor or a related device. The role of the camera ports is to receive input from video sources and to provide support for time-sensitive signals to the camera. Non-time-sensitive controls such as configuration, reset are performed by the ARM platform through I2C interface or GPIO signals.

The *SMARC* specification defines serial and parallel camera interface on the same pins. We can either implement it as serial or parallel camera interfaces. The camera interface on *SMARC-FiMX6* is designed as serial interfaces on CSI1 pin groups that can support 4 lanes or 2 lanes. The CSI0 interface is not connected on edge golden finger connector.

The following figure shows the serial camera interface block diagram.

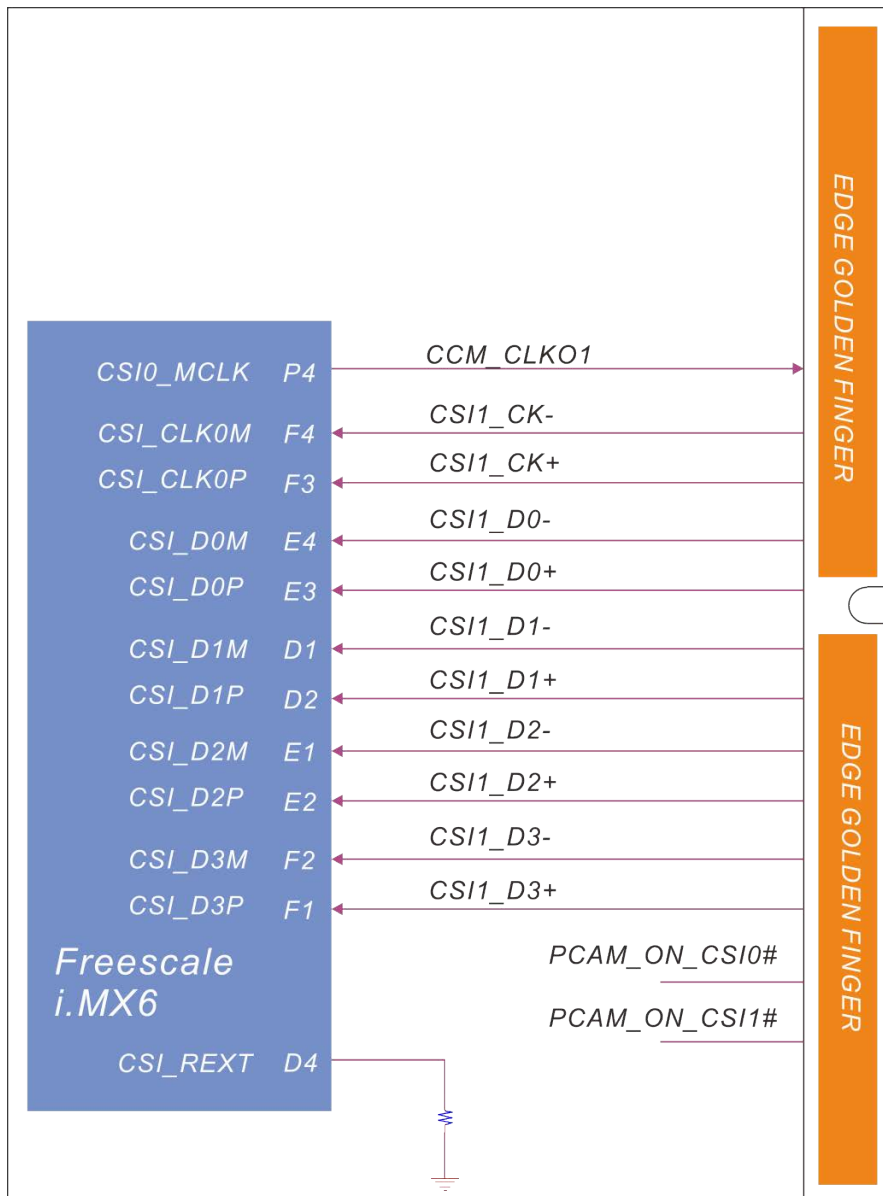

Figure 10. MIPI/Serial Camera Interface Block Diagram

**Embedian, Inc.**

MIPI/Serial Camera interface signals are exposed on the *SMARC-FiMX6* edge connector as shown below:

Freescale i.MX6 CPU			SMARC-FiMX6 Edge Golden Finger		Net Names	Note
Ball	Mode	Pin Name	Pin#	Pin Name		
<i>MIPI/Serial Camera Interface</i>						
A17	ALT4	NANDF_CS2__ CCM_CLK02	S6	CAM_MCK	CAM_MCK	Master clock output for CSI camera support
F4		CSI_CLK0M	P4	CSI1_CK-	CSI1_CK-	CSI1 differential clock inputs
F3		CSI_CLK0P	P3	CSI1_CK+	CSI1_CK+	
E4		CSI_D0M	P8	CSI1_D0-	CSI1_D0-	CSI1 differential data inputs
E3		CSI_D0P	P7	CSI1_D0+	CSI1_D0+	
D1		CSI_D1M	P11	CSI1_D1-	CSI1_D1-	
D2		CSI_D1P	P10	CSI1_D1+	CSI1_D1+	
E1		CSI_D2M	P14	CSI1_D2-	CSI1_D2-	
E2		CSI_D2P	P13	CSI1_D2+	CSI1_D2+	
F2		CSI_D3M	P17	CSI1_D3-	CSI1_D3-	
F1		CSI_D3P	P16	CSI1_D3+	CSI1_D3+	

### **2.1.16.1. Camera Type Pins**

*PCAM\_ON\_CSI1#* is used in SMARC specification to indicate to the Carrier what camera interface(s) are supported by the Module. This pin should be tied to *GND* on module if module supports a parallel camera interface on SMARC *CSI1* group. *SMARC-FiMX6* supports serial camera interface only and hence we leave this pin floating. The *CSI0* camera group is not used in *SMARC-FiMX6*, *PCAM\_ON\_CS0#* is also floating on module.

### **2.1.16.2. Camera I2C Support**

The *I2C\_CAM\_* port is intended to support serial and parallel cameras. Most contemporary cameras with I2C support allow a choice of two I2C address ranges.

<i>Edge Golden Finder Signal Name</i>	<i>Direction</i>	<i>Type Tolerance</i>	<i>Description</i>
<i>I2C_CAM_DAT</i>	<i>Bi-Dir OD</i>	<i>CMOS VDD_IO</i>	<i>Serial / Parallel camera support link - I2C data</i>
<i>I2C_CAM_CK</i>	<i>Bi-Dir OD</i>	<i>CMOS VDD_IO</i>	<i>Differential SATA 0 transmit data</i> <i>Series coupling caps is on the Module</i> <i>Caps is 0402 package 0.1uF</i>

**2.1.16.3. Serial Camera In – CSI1**

<i>Edge Golden Finder Signal Name</i>	<i>Direction</i>	<i>Type Tolerance</i>	<i>Description</i>
<i>CSI1_D[0:3]+ CSI1_D[0:3]-</i>	<i>Input</i>	<i>LVDS D-PHY</i>	<i>CSI1 differential data inputs</i>
<i>CSI1_CK+ CSI1_CK-</i>	<i>Input</i>	<i>LVDS D-PHY</i>	<i>CSI1 differential clock inputs</i>
<i>CAM_MCK</i>	<i>Output</i>	<i>CMOS VDD_IO</i>	<i>Master clock output for CSI1 camera support</i>

### 2.1.17. SD/SDMMC Interface

SMARC-FiMX6 is configured to support three MMC controllers. One is used for internal 8-bit eMMC support, and the other two could be used for external SDHC/SDIO interfaces. The SMARC-FiMX6 module supports two 4bit SDIO interface, per the SMARC specification. From the definition of SMARC specification, one will be interfaced to SD/SDHC card or device, and the other could be interfaced to external eMMC flash. However, they can be used as two SD/SDHC interfaces or external eMMC flash. The SDIO interface uses 3.3V signaling, per the SMARC spec and for compatibility with commonly available SDIO cards.

The following figure shows the SDIO/eMMC block diagram.

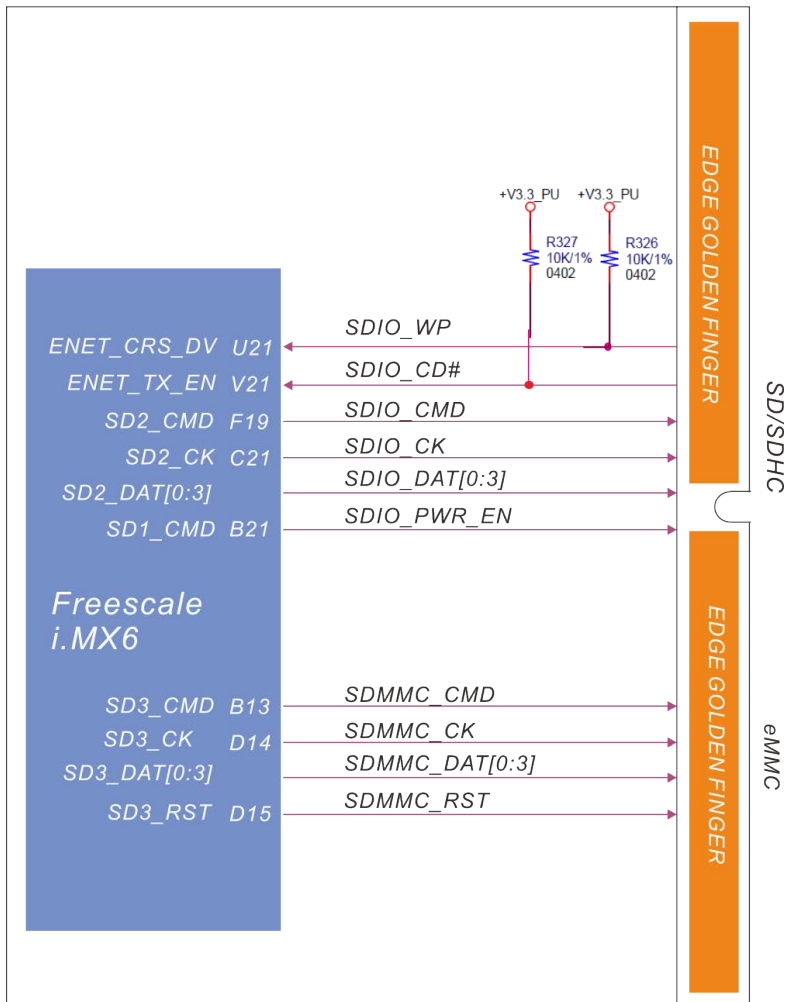

Figure 11. SD/SDIO/eMMC Interface Block Diagram

## Embedian, Inc.

SDIO and SDMMC interface signals are exposed on the SMARC golden finger edge connector as shown below:

Freescale i.MX6 CPU			SMARC-FiMX6 Edge Golden Finger		Net Names	Note
Ball	Mode	Pin Name	Pin#	Pin Name		
<b>SD/SDIO</b>						
A22	ALT0	SD2_DAT0__ SD2_DATA0	P39	SDIO_D0	SDIO_D0	SDIO Data 0
E20	ALT0	SD2_DAT1__ SD2_DATA1	P40	SDIO_D1	SDIO_D1	SDIO Data 1
A23	ALT0	SD2_DAT3__ SD2_DATA3	P41	SDIO_D2	SDIO_D2	SDIO Data 2
B22	ALT0	SD2_DAT3__ SD2_DATA3	P42	SDIO_D3	SDIO_D3	SDIO Data 3
U21	ALT0	ENET_CRS_DV__ GPIO1_I025	P33	SDIO_WP	SDIO_WP	SDIO write protect signal
F19	ALT0	SD2_CMD__ SD2_CMD	P34	SDIO_CMD	SDIO_CMD	SDIO Command signal
V21	ALT5	ENET_TX_EN__ GPIO1_I028	P35	SDIO_CD#	SDIO_CD#	SDIO card detect
C21	ALT0	SD2_CLK__ SD2_CLK	P36	SDIO_CK	SDIO_CK	SDIO Clock Signal
B21	ALT5	ENET_TX_EN__ GPIO1_I028	P37	SDIO_PWR_EN	SDIO_PWREN	SD card power enable

Freescale i.MX6 CPU			SMARC-FiMX6 Edge Golden Finger		Net Names	Note
Ball	Mode	Pin Name	Pin#	Pin Name		
<b>SDMMC</b>						
E14	ALT0	SD3_DAT0__ SD3_DATA0	S26	SDMMC_D0	SDMMC_D0	4-bit eMMC Data 0
F14	ALT0	SD3_DAT1__ SD3_DATA1	S27	SDMMC_D1	SDMMC_D1	4-bit eMMC Data 1
A15	ALT0	SD3_DAT2__ SD3_DATA2	S28	SDMMC_D2	SDMMC_D2	4-bit eMMC Data 2
B13	ALT0	SD3_DAT3__ SD3_DATA3	S29	SDMMC_D3	SDMMC_D3	4-bit eMMC Data 3
D14	ALT0	SD3_CLK__ SD3_CLK	S35	SDMMC_CK	SDMMC_CK	SDMMC Clock Signal
B13	ALT0	SD3_CMD__ SD3_CMD	S36	SDMMC_CMD	SDMMC_CMD	SDMMC Command signal
D15	ALT0	SD3_RST__ SD3_RESET	S37	SDMMC_RST#	SDMMC_RST#	Reset signal to eMMC device

**Note:**

1. The *SDIO* card power should be switched on the Carrier board and the *SDIO* lines should be *ESD* protected. The *SMARC* Evaluation Carrier schematic is useful as an implementation reference.
2. If **SD boot up function is required, the pull-up resistor to 3.3V of *SDIO\_PWR\_EN#* should be 4.7k or less.**
3. *SDIO\_WP* and *SDIO\_CD#* are 10k pull up to 3.3V on module.
4. If users would like to implement *SDMMC* interface as *SD/SDIO*, you can use other *GPIOs* for *WP* and *CD#* signals and use 10k pull-up resistors to 3.3V.



### **2.1.17.1. SDIO Card (4 bit) Interface**

The Carrier SDIO Card can be selected as the Boot Device (See section 4.3).

<i>Edge Golden Finder Signal Name</i>	<i>Direction</i>	<i>Type Tolerance</i>	<i>Description</i>
<i>SDIO_D[0:3]</i>	<i>Bi-Dir</i>	<i>CMOS 3.3V</i>	<i>4 bit data path</i>
<i>SDIO_CMD</i>	<i>Bi-Dir</i>	<i>CMOS 3.3V</i>	<i>Command Line</i>
<i>SDIO_CK</i>	<i>Output</i>	<i>CMOS 3.3V</i>	<i>Clock</i>
<i>SDIO_WP</i>	<i>Input</i>	<i>CMOS 3.3V</i>	<i>Write Protect</i>
<i>SDIO_CD#</i>	<i>Input</i>	<i>CMOS 3.3V</i>	<i>Card Detect</i>
<i>SDIO_PWR_EN</i>	<i>Output</i>	<i>CMOS 3.3V</i>	<i>SD Card Power Enable</i>

**Note:**

SD Cards are not typically available with a 1.8V I/O voltage. The Module SD Card I/O level is specified as 3.3V and not CMOS *VDD\_IO*.

### **2.1.17.2. eMMC (8 bit) Interface**

The SMARC Module pin definition allows for an 8 bit eMMC interface. However, SMARC-FiMX6 allows 4 bit eMMC interface on carrier board. There is an on-module 8 bit 8GB eMMC. Both the on-module and on-carrier eMMC be selected as the Boot Device – see Section 4.3 Boot Select.

<i>Edge Golden Finder Signal Name</i>	<i>Direction</i>	<i>Type Tolerance</i>	<i>Description</i>
<i>SDMMC_D[0:3]</i>	<i>Bi-Dir</i>	<i>CMOS VDDIO</i>	<i>4 bit data path</i>
<i>SDMMC_CMD</i>	<i>Bi-Dir</i>	<i>CMOS VDDIO</i>	<i>Command Line</i>
<i>SDMMC_CK</i>	<i>Output</i>	<i>CMOS VDDIO</i>	<i>Clock</i>
<i>SDMMC_RST</i>	<i>Output</i>	<i>CMOS VDDIO</i>	<i>Write Protect</i>

### 2.1.18. SPI Interface

The *SMARC-FiMX6* module supports two *Freescale i.MX6* SPI interfaces that are available off-Module for general purpose use. Each SPI channel has two chip-selects that can connect two SPI slave devices on each channel. Every device will share the "SPI\_DIN", "SPI\_DO" and "SPI\_CK" pins, but each device will have its own chip select pin. The chip select signal is a low active signal.

The 4MB onboard *SPI NOR* flash uses the *SPI0* interface with different chip select signal. The onboard *SPI NOR* flash on *SMARC-FiMX6* is used as first stage bootloader device. The module will always boot up from *SPI NOR* flash, and the firmware (first stage bootloader) in NOR flash will read the *BOOT\_SEL* configuration and load the second stage bootloader from the user assigned Boot Device.

The SPI interface is diagramed below.

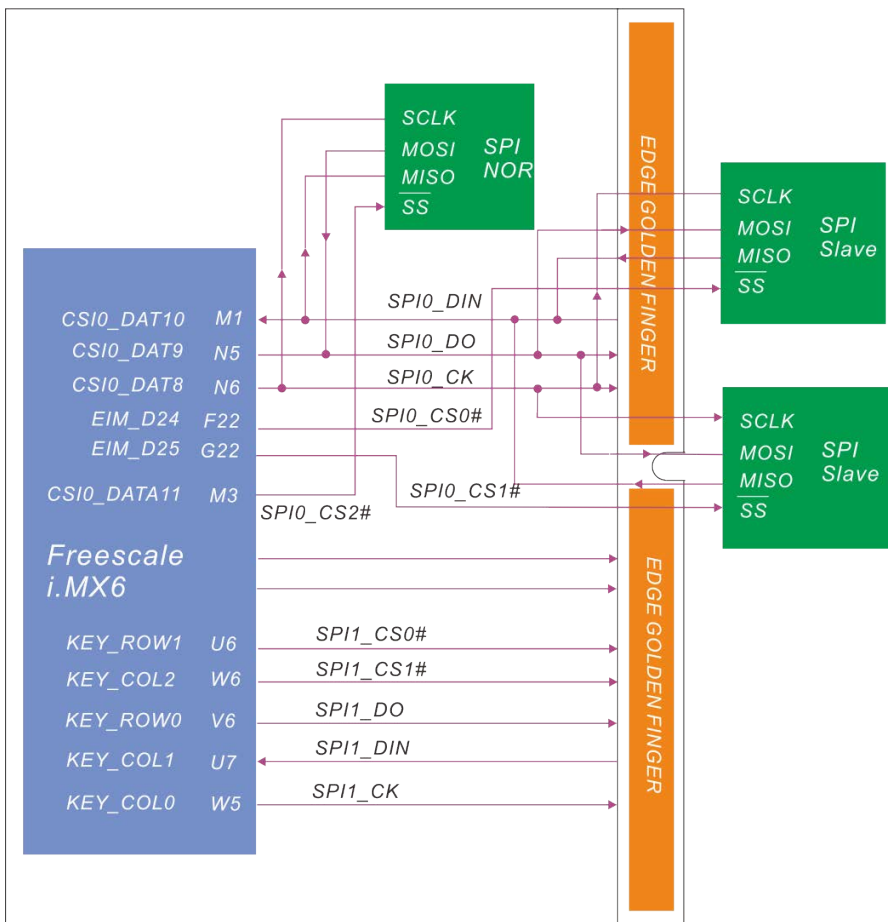

**Figure 12: SPI Serial Flash Schematics**

## Embedian, Inc.

SPI interface signals are exposed on the SMARC golden finger edge connector as shown below:

Freescale i.MX6 CPU			SMARC-FiMX6 Edge Golden Finger		Net Names	Note
Ball	Mode	Pin Name	Pin#	Pin Name		
<b>SPI0 Port</b>						
F22	ALT5	EIM_D24__ GPIO3_I024	P43	SPI0_CS0#	SPI0_CS0#	SPI0 Master Chip Select 0 output, reserve for onboard NOR flash
G22	ALT5	EIM_D25__GPI 03_I025	P31	SPI0_CS1#	SPI0_CS1#	SPI0 Master Chip Select 1 output
N6	ALT2	CSI0_DAT8__ ECSPI2_SCLK	P44	SPI0_CK	SPI0_SCLK	SPI0 Master Clock output
M1	ALT2	CSI0_DAT10__ ECSPI2_MISO	P45	SPI0_DIN	SPI0_DIN	SPI0 Master Data input (input to CPU, output from SPI device)
N5	ALT2	CSI0_DAT9__ ECSPI2_MOSI	P46	SPI0_DO	SPI0_DO	SPI0 Master Data output (output from CPU, input to SPI device)
M3	ALT5	CSI0_DAT11__ GPIO5_I029	--	--	--	Chip select for SPI NOR Flash
<b>SPI1 Port</b>						
U6	ALT5	KEY_ROW1__ GPIO4_I009	P54	SPI1_CS0#	SPI1_CS0#	SPI1 Master Chip Select 0 output
W6	ALT5	KEY_COL2__ GPIO4_I010	P55	SPI1_CS1#	SPI1_CS1#	SPI1 Master Chip Select 1 output
W5	ALT0	KEY_COL0__ ECSPI1_SCLK	P56	SPI1_CK	SPI1_SCLK	SPI1 Master Clock output
U7	ALT0	KEY_COL1__ ECSPI1_MISO	P57	SPI1_DIN	SPI1_MISO	SPI1 Master Data input (input to CPU, output from SPI device)
V6	ALT0	KEY_ROW0__ ECSPI1_MOSI	P58	SPI1_DO	SPI1_MOSI	SPI1 Master Data output (output from CPU, input to SPI device)

### **2.1.18.1. SPI0 Signals**

The Carrier SPI0 device may be selected as the Boot Device – see Section 4.3 Boot Select.

<i>Edge Golden Finder Signal Name</i>	<i>Direction</i>	<i>Type Tolerance</i>	<i>Description</i>
<i>SPI0_CS0#</i>	<i>Output</i>	<i>CMOS VDDIO</i>	<i>SPI0 Master Chip Select 0 output</i>
<i>SPI0_CS1#</i>	<i>Output</i>	<i>CMOS VDDIO</i>	<i>SPI0 Master Chip Select 1 output</i>
<i>SPI0_CK</i>	<i>Output</i>	<i>CMOS VDDIO</i>	<i>SPI0 Master Clock output</i>
<i>SPI0_DIN</i>	<i>Input</i>	<i>CMOS VDDIO</i>	<i>SPI0 Master Data input (input to CPU, output from SPI device)</i>
<i>SPI0_DO</i>	<i>Output</i>	<i>CMOS VDDIO</i>	<i>SPI0 Master Data output (output from CPU, input to SPI device)</i>

**2.1.18.2. SPI1 Signals**

<i>Edge Golden Finder Signal Name</i>	<i>Direction</i>	<i>Type Tolerance</i>	<i>Description</i>
<i>SPI1_CS0#</i>	<i>Output</i>	<i>CMOS VDDIO</i>	<i>SPI1 Master Chip Select 0 output</i>
<i>SPI1_CS1#</i>	<i>Output</i>	<i>CMOS VDDIO</i>	<i>SPI1 Master Chip Select 1 output</i>
<i>SPI1_CK</i>	<i>Output</i>	<i>CMOS VDDIO</i>	<i>SPI1 Master Clock output</i>
<i>SPI1_DIN</i>	<i>Input</i>	<i>CMOS VDDIO</i>	<i>SPI1 Master Data input (input to CPU, output from SPI device)</i>
<i>SPI1_DO</i>	<i>Output</i>	<i>CMOS VDDIO</i>	<i>SPI1 Master Data output (output from CPU, input to SPI device)</i>

### 2.1.19. I2S Interface

The *SMARC-FiMX6* module uses *I2S* format for Audio signals. These signals are derived from the Synchronous Serial Interface (SSI) of the *Freescale® i.MX6* processor. The SSI is a full duplex serial port that allows communication with external devices using a variety of serial protocols. The *I2S* protocol is part of the protocols supported by the *Freescale® i.MX6* Cortex A9 processor. The SSI supports up to 1.4 Mbps.

*I2S* interface signals are exposed on the *SMARC-FiMX6* golden finger edge connector as shown below:

Freescale i.MX6 CPU			SMARC-FiMX6 Edge Golden Finger		Net Names	Note
Ball	Mode	Pin Name	Pin#	Pin Name		
P4	ALT3	CSI0_MCLK__ CCM_CLK01	S38	Audio_MCK	AUD_MCLK	Master clock output to Audio codecs
N4	ALT4	CSI0_DAT6__ AUD3_TXFS	S39	I2S0_LRCK	I2S0_LRCK	Left& Right audio synchronization clock
P2	ALT4	CSI0_DAT5__ AUD3_TXD	S40	I2S0_SDOUT	I2S0_SDOUT	Digital audio Output
N3	ALT4	CSI0_DAT7__ AUD3_RXD	S41	I2S0_SDIN	I2S0_SDIN	Digital audio Input
N1	ALT4	CSI0_DAT4__ AUD3_TXC	S42	I2S0_CK	I2S0_CK	Digital audio clock

**Note:**

*SMARC-FiMX6* currently supports only *I2S* format. *SGTL5000 I2S* audio codec is used in *EVK-STD-CARRIER* evaluation carrier board. An external 24.576 Mhz crystal is used as a reference clock output to audio codec instead of Pin S38. Theoretically, both ways will work.

**2.1.19.1 I2S0 Signals**

<i>Edge Golden Finder Signal Name</i>	<i>Direction</i>	<i>Type Tolerance</i>	<i>Description</i>
<i>I2S0_LRCK</i>	<i>Bi-Dir</i>	<i>CMOS VDDIO</i>	<i>Left&amp; Right audio synchronization clock</i>
<i>I2S0_SDOUT</i>	<i>Output</i>	<i>CMOS VDDIO</i>	<i>Digital audio Output</i>
<i>I2S0_SDIN</i>	<i>Input</i>	<i>CMOS VDDIO</i>	<i>Digital audio Input</i>
<i>I2S0_CK</i>	<i>Bi-Dir</i>	<i>CMOS VDDIO</i>	<i>Digital audio clock</i>
<i>I2S0_MCK</i>	<i>Output</i>	<i>CMOS VDDIO</i>	<i>Master clock output to Audio codecs</i>



### **2.1.20 SPDIF Interface**

SPDIF interface signals are exposed on the *SMARC-FiMX6* golden finger edge connector as shown below:

<i>Freescale i.MX6 CPU</i>			<i>SMARC-FiMX6 Edge Golden Finger</i>		<i>Net Names</i>	<i>Note</i>
<i>Ball</i>	<i>Mode</i>	<i>Pin Name</i>	<i>Pin#</i>	<i>Pin Name</i>		
<i>R1</i>	<i>ALT4</i>	<i>GPIO_17__ SPDIF_OUT</i>	<i>S59</i>	<i>SPDIF_OUT</i>	<i>SPDIF_OUT</i>	<i>Digital Audio Out</i>
<i>R2</i>	<i>ALT4</i>	<i>GPIO_16__ SPDIF_IN</i>	<i>S60</i>	<i>SPDIF_IN</i>	<i>SPDIF_IN</i>	<i>Digital Audio In</i>

#### **2.1.20.1 SPDIF Signals**

<i>Edge Golden Finder Signal Name</i>	<i>Direction</i>	<i>Type Tolerance</i>	<i>Description</i>
<i>SPDIF_OUT</i>	<i>Output</i>	<i>CMOS VDDIO</i>	<i>Digital Audio Out</i>
<i>SPDIF_IN</i>	<i>Input</i>	<i>CMOS VDDIO</i>	<i>Digital Audio In</i>

### **2.1.21. Asynchronous Serial Port**

The *SMARC-FiMX6* module supports four UARTs (*SER0:3*). UART *SER0* and *SER2* support flow control signals (*RTS#*, *CTS#*). UART *SER1* and *SER3* do not support flow control (*TX*, *RX* only). When working with software, *SER 3* is used for *SMARC-FiMX6* debugging console port.

The module asynchronous serial port signals have a *VDDIO* (1.8V or 3.3V) level signal swing. They can be converted to RS232 level and polarity signals by using a suitable RS232 transceiver. Almost all transceivers available accept a 3.3V signal level: example include the Texas Instruments MAX3243. Note that RS232 transceivers invert the signal; a logic '1' is a negative voltage (-3.0V to -15V) and a logic '0' a positive voltage (3.0V to 15V) on the RS232 line.

If users using 1.8V *VDDIO* module, a level-shift IC from 1.8V to 3.3V might be required.

## Embedian, Inc.

Asynchronous serial ports interface signals are exposed on the SMARC golden finger edge connector as shown below:

Freescale i.MX6 CPU			SMARC-FiMX6 Edge Golden Finger		Net Names	Note
Ball	Mode	Pin Name	Pin#	Pin Name		
<b>SER0 Port</b>						
F13	ALT1	SD3_DAT7__ UART1_TX_DATA	P129	SER0_TX	SER0_TX	Asynchronous serial port data out
E13	ALT1	SD3_DAT6__ UART1_RX_DATA	P130	SER0_RX	SER0_RX	Asynchronous serial port data in
G21	ALT4	EIM_D19__ UART1_RTS_B	P131	SER0_RTS#	SER0_RTS#	Request to Send handshake line for SER0
G20	ALT4	EIM_D20__ UART1_CTS_B	P132	SER0_CTS#	SER0_CTS#	Clear to Send handshake line for SER0
<b>SER1 Port</b>						
E24	ALT4	EIM_D26__ UART2_TX_DATA	P134	SER1_TX	SER1_TX	Asynchronous serial port data out
E25	ALT4	EIM_D27__ UART2_RX_DATA	P135	SER1_RX	SER1_RX	Asynchronous serial port data in
<b>SER2 Port</b>						
M2	ALT3	CSI0_DAT12__ UART4_TX_DATA	P136	SER2_TX	SER2_TX	Asynchronous serial port data out
L1	ALT3	CSI0_DAT13__ UART4_RX_DATA	P137	SER2_RX	SER2_RX	Asynchronous serial port data in
L3	ALT3	CSI0_DAT17__ UART4_RTS_B	P138	SER2_RTS#	SER2_RTS#	Request to Send handshake line for SER2
L4	ALT3	CSI0_DAT16__ UART4_CTS_B	P139	SER2_CTS#	SER2_CTS#	Clear to Send handshake line for SER2
<b>SER3 Port (Debugging Port)</b>						
M4	ALT3	CSI0_DAT14__ UART5_TX_DATA	P140	SER3_TX	SER3_TX	Asynchronous serial port data out
M5	ALT3	CSI0_DAT15__ UART5_RX_DATA	P141	SER3_RX	SER3_RX	Asynchronous serial port data in

### **2.1.21.1. UART Signals**

Module pins for up to four asynchronous serial ports are defined. The ports are designated *SER0* – *SER3*. Ports *SER0* and *SER2* are 4 wire ports (2 data lines and 2 handshake lines). Ports *SER1* and *SER3* are 2 wire ports (data only).

<b>Edge Golden Finder Signal Name</b>	<b>Direction</b>	<b>Type Tolerance</b>	<b>Description</b>
<i>SER[0:3]_TX</i>	<i>Output</i>	<i>CMOS VDDIO</i>	<i>Asynchronous serial port data out</i>
<i>SER[0:3]_RX</i>	<i>Input</i>	<i>CMOS VDDIO</i>	<i>Asynchronous serial port data in</i>
<i>SER[0]_RTS#</i>	<i>Output</i>	<i>CMOS VDDIO</i>	<i>Request to Send handshake line for SER0</i>
<i>SER[0]_CTS#</i>	<i>Input</i>	<i>CMOS VDDIO</i>	<i>Clear to Send handshake line for SER0</i>
<i>SER[2]_RTS#</i>	<i>Output</i>	<i>CMOS VDDIO</i>	<i>Request to Send handshake line for SER2</i>
<i>SER[2]_CTS#</i>	<i>Input</i>	<i>CMOS VDDIO</i>	<i>Clear to Send handshake line for SER2</i>

### 2.1.22. I2C Interface

There is a minimum configuration of I2C ports up to a maximum of 5 ports defined in the SMARC specification: PM (Power Management), LCD (Liquid Crystal Display), GP (General Purpose), CAM (Camera) and HDMI. SMARC-FiMX6 defines all of the five I2C buses and supports multiple masters and slaves in fast mode (400 KHz operation).

The *I2C\_PM* is implemented directly from Freescale *i.MX6 I2C1* interfaces. The *I2C\_HDMI* is implemented directly from Freescale *i.MX6 I2C2* interfaces. The *I2C\_GP*, *I2C\_LCD* and *I2C\_CAM* are implemented from Freescale *i.MX6 I2C3* interfaces to a Texas Instrument *TCA9546A* 1-to-4 bi-directional translating switch at address *0x70*.

The following diagram shows the SMARC-FiMX6 I2C interfaces.

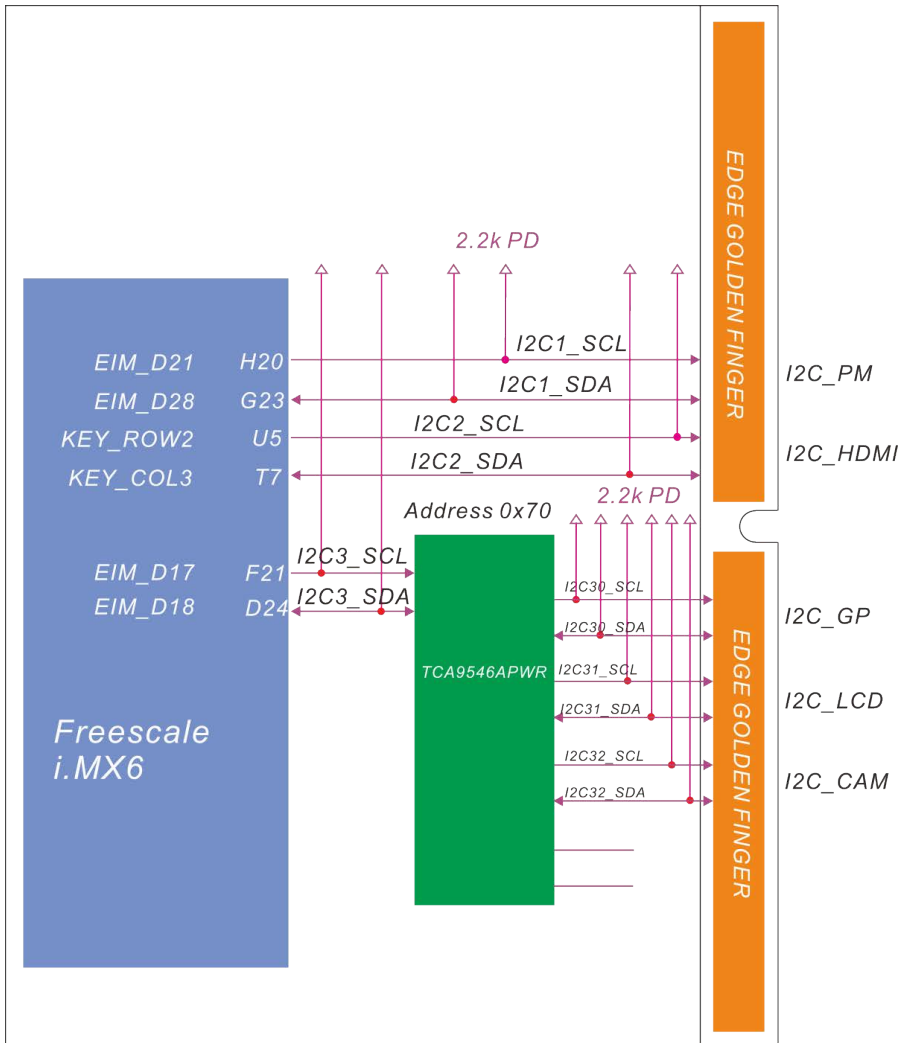

Figure 13: I2C Interface Block Diagram

## Embedian, Inc.

This will be summarized below.

<i>I2C Port</i>		<i>Primary Purpose</i>	<i>Alternative Use</i>	<i>I/O Voltage Level</i>
<i>Golden Finger Connector</i>	<i>i.MX6 CPU</i>			
<i>I2C_PM</i>	<i>I2C1</i>	<i>Power Management support</i>	<i>System configuration management</i>	<i>CMOS 1.8V</i>
<i>I2C_GP</i>	<i>I2C30</i>	<i>General purpose use</i>		<i>CMOS VDDIO</i>
<i>I2C_LCD</i>	<i>I2C31</i>	<i>LCD display support, to read LCD display EDID EEPROMs  (for parallel and LVDS LCD,)</i>	<i>General Purpose</i>	<i>CMOS VDDIO</i>
<i>I2C_CAM</i>	<i>I2C32</i>	<i>Serial / Parallel camera</i>	<i>General Purpose</i>	<i>CMOS VDDIO</i>
<i>I2C_HDMI</i>	<i>I2C2</i>	<i>Dedicated to HDMI</i>		<i>CMOS VDDIO</i>

### **Note:**

The 2.2k pull-up resistors for *I2C\_SCL* and *I2C\_SDA* signals are on module.

## Embedian, Inc.

The I2C interface signals are exposed on the SMARC golden finger edge connector as shown below:

Freescale i.MX6 CPU			SMARC-FiMX6 Edge Golden Finger		Net Names	Note
Ball	Mode	Pin Name	Pin#	Pin Name		
<b>I2C_PM</b>						
H20	ALT6	EIM_D21__ I2C1_SCL	P121	I2C_PM_CK	I2C_PM_CK	Power management I2C bus clock
G23	ALT1	EIM_D28__ I2C1_SDA	P122	I2C_PM_DAT	I2C_PM_SDA	Power management I2C bus data
<b>I2C_GP</b>						
TCA9546		I2C30_SCL	S48	I2C_GP_CK	I2C_GP_CK	General purpose I2C bus clock
		I2C30_SDA	S49	I2C_GP_DAT	I2C_GP_DAT	General purpose I2C bus data
<b>I2C_LCD</b>						
TCA9546		I2C31_SCL	S139	I2C_LCD_CK	I2C_LCD_CK	LCD display I2C bus clock
		I2C31_SDA	S140	I2C_LCD_DAT	I2C_LCD_DAT	LCD display I2C bus data
<b>I2C_CAM</b>						
TCA9546		I2C32_SCL	S5	I2C_CAM_CK	I2C_CAM_CK	Camera I2C bus clock
		I2C32_SDA	S7	I2C_CAM_DAT	I2C_CAM_DAT	Camera I2C bus data
<b>I2C_HDMI</b>						
U5	ATT4	KEY_COL3__ I2C2_SCL	P105	HDMI_CTRL_CK	HDMI_CTRL_CK	HDMI I2C bus clock
T7	ALT4	KEY_ROW3__ I2C2_SDA	P106	HDMI_CTRL_DAT	HDMI_CTRL_DAT	HDMI I2C bus data

### Note:

The Ball of I2C3\_SCL is F21 and is configured as ALT6, and pin name is EIM\_D17\_\_I2C3\_SCL. The Ball of I2C3\_SDA is D24 and is configured as ALT6 as well, and the pin name is EIM\_D18\_\_I2C3\_SDA.

## Embedian, Inc.

There are three I2C devices on the *SMARC-FiMX6* Module and two of them are on the *I2C\_PM (I2C1)* bus and are operated at 1.8V. The other one is on *I2C3* bus. Those devices and their address details are listed in the following table:

#	Device	Description	Address (7-bit)	Address (8-bit)		Notes
				Read	Write	
<i>I2C_PM (I2C1) Bus</i>						
1	<i>On Semiconductor CAT24C32</i>	<i>EEPROM</i>	<i>0x50</i>	<i>0xA1</i>	<i>0xA0</i>	<i>General purpose parameter EEPROM, Serial number, etc in PICMG EEPROM format</i>
2	<i>Seiko S-35390A</i>	<i>Real-time clock IC</i>	<i>0x30</i>	<i>0x61</i>	<i>0x60</i>	<i>General purpose parameter with INT1 register access</i>
<i>I2C3 Bus</i>						
1	<i>TI TCA9546APWR</i>	<i>4-channel I2C Switch</i>	<i>0x70</i>	<i>0xE1</i>	<i>0xE0</i>	<i>1-to-4 I2C Bidirectional Translating Switches</i>



### 2.1.23. CAN Bus Interface

The Controller Area Network (CAN) is a serial communications protocol which efficiently supports distributed real-time control with a high level of security. The *SMARC-FiMX6* module supports two CAN bus interfaces. CAN interface signals are exposed on the *SMARC* golden finger edge connector as shown below:

Freescale i.MX6 CPU			SMARC-FiMX6 Edge Golden Finger		Net Names	Note
Ball	Mode	Pin Name	Pin#	Pin Name		
<b>CAN0 BUS</b>						
R3	ALT3	GPI0_7__ FLEXCAN1_TX	P143	CAN0_TX	CAN0_TX	CAN0 Transmit output
R5	ALT3	GPI0_8__ FLEXCAN1_RX	P144	CAN0_RX	CAN0_RX	CAN0 Receive input
<b>CAN1 BUS</b>						
T6	ALT0	KEY_COL4__ FLEXCAN2_TX	P145	CAN1_TX	CAN1_TX	CAN1 Transmit output
V5	ALT0	KEY_ROW4__ FLEXCAN2_RX	P146	CAN1_RX	CAN1_RX	CAN1 Receive input

By *SMARC* hardware specification, *CAN0* bus error condition signaling should be supported on the Module *GPI08 (P116)* pin. This is an active low input to the Module from the CAN bus transceiver. *CAN1* bus error condition signaling should be supported on the Module *GPI09 (P117)* pin. This is an active low input to the Module from the CAN bus transceiver. A CAN transceiver on carrier is necessary to adapt the signals from *SMARC* golden finger edge connector, which is TTL levels, to the physical layer used. Because the CAN bus system is typically used to connect multiple systems and is often run over very long distances, both power supply and signal path must be electrically isolated to meet a certain isolation level. Users can refer the “**SMARC Carrier Board Hardware Design Guide**” or CAN transceiver application note such as TI ISO1050 for more details.

### 2.1.23.1. CAN0 BUS Signals

<i>Edge Golden Finder Signal Name</i>	<i>Direction</i>	<i>Type Tolerance</i>	<i>Description</i>
CAN0_TX	Output	CMOS VDDIO	CAN0 Transmit output
CAN0_RX	Input	CMOS VDDIO	CAN0 Receive input

### 2.1.23.2. CAN1 BUS Signals

<i>Edge Golden Finder Signal Name</i>	<i>Direction</i>	<i>Type Tolerance</i>	<i>Description</i>
CAN1_TX	Output	CMOS VDDIO	CAN1 Transmit output
CAN1_RX	Input	CMOS VDDIO	CAN1 Receive input

#### **2.1.24. GPIOs**

The *SMARC-FiMX6* module supports 12 GPIOs, per the *SMARC* specification. Specific alternate functions are assigned to some GPIOs such as PWM / Tachometer capability, Camera support, CAN Error Signaling and HD Audio reset. All pins are capable of bi-directional operation. A default direction of operation is assigned, with half of them (GPIO0 – GPIO5) for use as outputs and the remainder (GPIO6 – GPIO11) as inputs by *SMARC* hardware specification.

## Embedian, Inc.

GPIO signals are exposed on the SMARC golden finger edge connector as shown below:

Freescale i.MX6 CPU			SMARC-FiMX6 Edge Golden Finger		Net Names	Note
Ball	Mode	Pin Name	Pin#	Pin Name		
<b>GPIOs</b>						
F15	ALT5	NANDF_CS0__ GPIO6_I011	P108	GPIO0/CAM0_PWR#	GPIO0	Camera 0 Power Enable, active low output
F16	ALT5	NANDF_D2__ GPIO2_I002	P109	GPIO1/CAM1_PWR#	GPIO1	Camera 1 Power Enable, active low output
E17	ALT5	NANDF_D6__ GPIO2_I006	P110	GPIO2/CAM0_RST#	GPIO2	Camera 0 Reset, active low output
D17	ALT5	NANDF_D3__ GPIO2_I003	P111	GPIO3/CAM1_RST#	GPIO3	Camera 1 Reset, active low output
C18	ALT5	NANDF_D7__ GPIO2_I007	P112	GPIO4/HDA_RST#	GPIO4	HD Audio Reset, active low output
F18	ALT5	SD1_DAT3__ GPIO1_I021	P113	GPIO5/PWM_OUT	GPIO5	PWM output
C16	ALT5	NANDF_CS1__ GPIO6_I014	P114	GPIO6/TACHIN	GPIO6	Tachometer input (used with the GPIO5 PWM)
C15	ALT5	NANDF_CLE__ GPIO6_I007	P115	GPIO7/PCAM_FLD	GPIO7	PCAM_FLD (Field) signal input
A19	ALT5	NANDF_D4__ GPIO2_I004	P116	GPIO8/CAN0_ERR#	GPIO8	CAN0 Error signal, active low input
A18	ALT5	NANDF_D0__ GPIO2_I000	P117	GPIO9/CAN1_ERR#	GPIO9	CAN1 Error signal, active low input
B18	ALT5	NANDF_D5__ GPIO2_I005	P118	GPIO10	GPIO10	
A16	ALT5	NANDF_ALE__ GPIO6_I008	P119	GPIO11	GPIO11	

### 2.1.24.1. GPIO Signals

Twelve Module pins are allocated for GPIO (general purpose input / output) use. All pins are capable of bi-directional operation. By SMARC specification, *GPIO0 – GPIO5* are recommended for use as outputs and the remainder (*GPIO6 – GPIO11*) as inputs.

At Module power-up, the state of the GPIO pins may not be defined, and may briefly be configured in the “wrong” state, before boot loader code corrects them. Carrier designers should be aware of this and plan accordingly.

All GPIO pins are capable of generating interrupts. The interrupt characteristics (edge or level sensitivity, polarity) are generally configurable in the *i.MX6* register set.

<i>Edge Golden Finder Signal Name</i>	<i>Preferred Direction</i>	<i>Type Tolerance</i>	<i>Description</i>
<i>GPIO0/CAM0_PWR#</i>	<i>Output</i>	<i>CMOS VDDIO</i>	<i>Camera 0 Power Enable, active low output</i>
<i>GPIO1/CAM1_PWR#</i>	<i>Output</i>	<i>CMOS VDDIO</i>	<i>Camera 1 Power Enable, active low output</i>
<i>GPIO2/CAM0_RST#</i>	<i>Output</i>	<i>CMOS VDDIO</i>	<i>Camera 0 Reset, active low output</i>
<i>GPIO3/CAM1_RST#</i>	<i>Output</i>	<i>CMOS VDDIO</i>	<i>Camera 1 Reset, active low output</i>
<i>GPIO4/HDA_RST#</i>	<i>Output</i>	<i>CMOS VDDIO</i>	<i>HD Audio Reset, active low output</i>
<i>GPIO5/PWM_OUT</i>	<i>Output</i>	<i>CMOS VDDIO</i>	<i>PWM output</i>
<i>GPIO6/TACHIN</i>	<i>Input</i>	<i>CMOS VDDIO</i>	<i>Tachometer input (used with the GPIO5 PWM)</i>
<i>GPIO7/PCAM_FLD</i>	<i>Input</i>	<i>CMOS VDDIO</i>	<i>PCAM_FLD (Field) signal input</i>
<i>GPIO8/CAN0_ERR#</i>	<i>Input</i>	<i>CMOS VDDIO</i>	<i>CAN0 Error signal, active low input</i>
<i>GPIO9/CAN1_ERR#</i>	<i>Input</i>	<i>CMOS VDDIO</i>	<i>CAN1 Error signal, active low input</i>
<i>GPIO10</i>	<i>Input</i>	<i>CMOS VDDIO</i>	
<i>GPIO11</i>	<i>Input</i>	<i>CMOS VDDIO</i>	

### 2.1.25. Watchdog Timer Interface

*i.MX6* features an internal WDT. Embedian's Linux kernel enables the internal *i.MX6* WDT and makes this functionality available to users through the standard Linux Watchdog API.

A description of the API is available following the link below:

<http://www.kernel.org/doc/Documentation/watchdog/watchdog-api.txt>

WDT signals are exposed on the *SMARC* golden finger edge connector as shown below:

Freescale <i>i.MX6</i> CPU			SMARC-FiMX6 Edge Golden Finger		Net Names	Note
Ball	Mode	Pin Name	Pin#	Pin Name		
<i>Watchdog Timer</i>						
T2	ALT1	GPIO_9__ WDOG1_B	S145	WDT_TIME_OUT#	WDT_TIME_OUT#	Watchdog-Timer Output

### 2.1.26. JTAG

Figure 14 shows the *SMARC-FiMX6* JTAG connectors location and pin out.

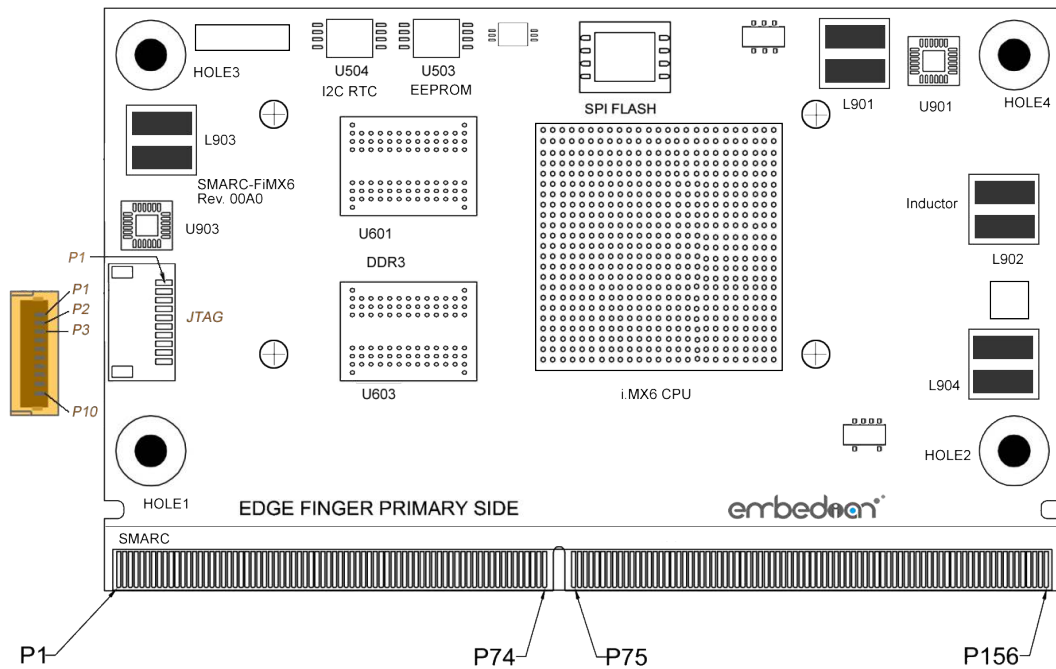

**Figure 14: JTAG Connector Location and Pinout**

JTAG functions for CPU debug and test are implemented on separate small form factor connector (CN3: *JST SM10B-SRSS-TB*, 1mm pitch R/A SMD Header). The JTAG pins are used to allow test equipment and circuit emulators to have access to the Module CPU. The pin-outs shown below are used:

Freescale i.MX6 CPU			JTAG(Connector: JST SM10B-SRSS-TB, 1mm pitch R/A SMD Header)		Type	Note
Ball	Mode	Pin Name	Pin#	Pin Name		
<b>JTAG</b>						
			1	VDD_33A	Power	JTAG I/O Voltage (sourced by Module)
C2	ATL0	JTAG_TRSTB	2	nTRST	I	JTAG Reset, active Low
C3	ALT0	JTAG_TMS	3	TMS	I	JTAG mode select
G6	ALT0	JTAG_TDO	4	TDO	O	JTAG data out
G5	ALT0	JTAG_TDI	5	TDI	I	JTAG data in
H5	ALT0	JTAG_TCK	6	TCK	I	JTAG clock
			7	RTCK	I	JTAG return clock
			8	GND	Ground	Ground
			9	MFG_Mode#	I	Pulled low to allow in-circuit SPI ROM update
			10	GND	Ground	Ground

### 2.1.27. Boot ID EEPROM

The *SMARC-FiMX6* module includes an I2C serial EEPROM available on the *I2C\_PM* bus. An On Semiconductor 24C32 or equivalent EEPROM is used in the module. The device operates at 1.8V. The Module serial EEPROM is placed at I2C slave addresses A2 A1 A0 set to 0 (I2C slave address 50 hex, 7 bit address format or A0 / A1 hex, 8 bit format) (for I2C EEPROMs, address bits A6 A5 A4 A3 are set to binary 0101 convention).

The module serial EEPROM is intended to retain module parameter information, including serial number. The module serial EEPROM data structure conforms to the PICMG® EEEP Embedded EEPROM Specification.



**Note:**

The *EEPROM ID* memory layout is now follow the mainline and as follows.

<b>Name</b>	<b>Size (Bytes)</b>	<b>Contents</b>
<b>Header</b>	4	MSB 0xEE3355AA LSB
<b>Board Name</b>	8	<p>Name for Board in ASCII “SMCMXQ1G” = Embedian SMARC-FiMX6 Computer on Module with Quad Core and 1GB DDR3 Configuration</p> <p>“SMCMXQ2G” = Embedian SMARC-FiMX6 Computer on Module with Quad Core and 2GB DDR3 Configuration</p> <p>“SMCMXD1G” = Embedian SMARC-FiMX6 Computer on Module with Dual Core and 1GB DDR3 Configuration</p> <p>“SMCMXD2G” = Embedian SMARC-FiMX6 Computer on Module with Dual Core and 2GB DDR3 Configuration</p> <p>“SMCMXU1G” = Embedian SMARC-FiMX6 Computer on Module with DualLite Core and 1GB DDR3 Configuration</p> <p>“SMCMXS00” = Embedian SMARC-FiMX6 Computer on Module with Solo Core and 512MB DDR3 Configuration</p>
<b>Version</b>	4	Hardware version code for version in ASCII “00A0” = rev. A0
<b>Serial Number</b>	12	<p>Serial number of the board. This is a 12 character string which is: WWYYMSD1nnnn</p> <p>Where: WW = 2 digit week of the year of production</p> <p>YY = 2 digit year of production</p> <p>MS = Module Serial Number</p> <p>D1/Q1/D2/Q2/UC/SC = CPU Core and DDR Configuration Variants</p> <p>nnnn = incrementing board number</p>
<b>Configuration Option</b>	32	<p>Codes to show the configuration setup on this board. For the available module variants supported, the following codes are used:</p> <p>ASCII = “SMCMXQ1G” = default configuration</p> <p>Remaining 24 bytes are reserved</p>
<b>MAC Address</b>	6	Ethernet MAC Address (10:0D:32:XX:XX:XX)
<b>MAC Address</b>	6	Ethernet MAC Address for 2 <sup>nd</sup> LAN (if any)
<b>AvaiLable</b>	32720	Available space for other non-volatile codes/data

## 2.2 SMARC-FiMX6 Debug

### 2.2.1. Serial Port Debug

SMARC module has 4 serial output ports, *SER0*, *SER1*, *SER2* and *SER3*. Out of these 4 serial ports, *SER3* is set as the serial debug port use for i.MX6 from Embedian. Users can change to any port they want to. *SER3* is exposed (along with all other serial ports available on the module) in the *SMARC-FiMX6* Evaluation Carrier. The default baud rate setting is 115,200 8N1.

*SER3* pin out of the *SMARC-FiMX6* is shown below:

Freescale i.MX6 CPU		SMARC-FiMX6 Edge Golden Finger		Net Names	Notes
mode	Pin Name	Pin#	Pin Name		
<i>SER3 (Debugging Port)</i>					
ALT3	CSI0_DAT14__ UART5_TX_DATA	P140	SER3_TX	SER3_TX	Asynchronous serial port data out
ALT3	CSI0_DAT15__ UART5_RX_DATA	P141	SER3_RX	SER3_RX	Asynchronous serial port data in

## 2.3 Mechanical Specifications

### 2.3.1. Module Dimensions

The *SMARC-FiMX6* complies with *SMARC* Hardware Specification in an 82mm x 50 mm form factor.

### 2.3.2. Height on Top

2.9mm maximum (without PCB) complied with *SMARC* specification defines as 3mm as the maximum.

### 2.3.3. Height on Bottom

0.9mm maximum (without PCB) complied with *SMARC* specification defines as 1.3mm as the maximum.

### 2.3.4. Mechanical Drawings

The mechanical information is shown in Figure 15: *SMARC-FiMX6* Mechanical Drawings (Top View) and Figure 16: *SMARC-FiMX6* Mechanical Drawings (Bottom View)

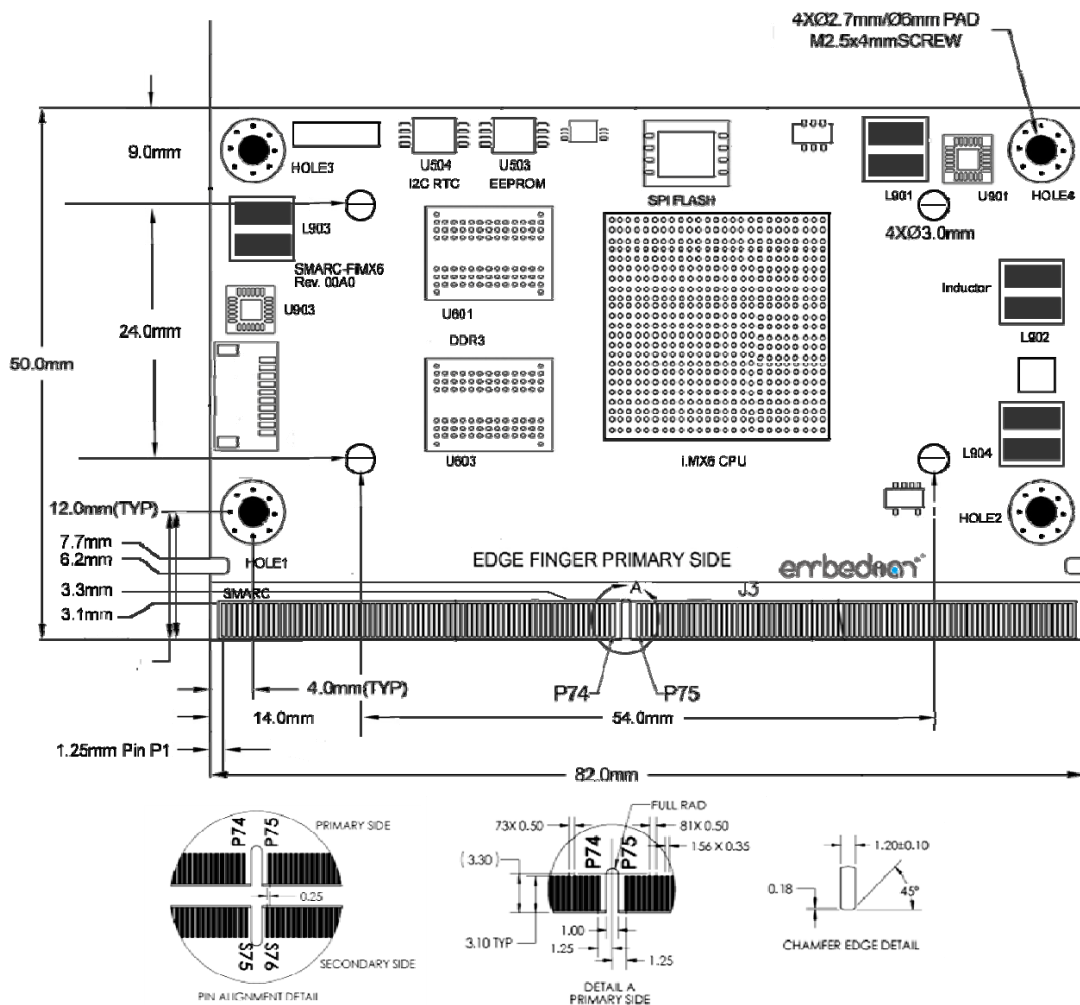
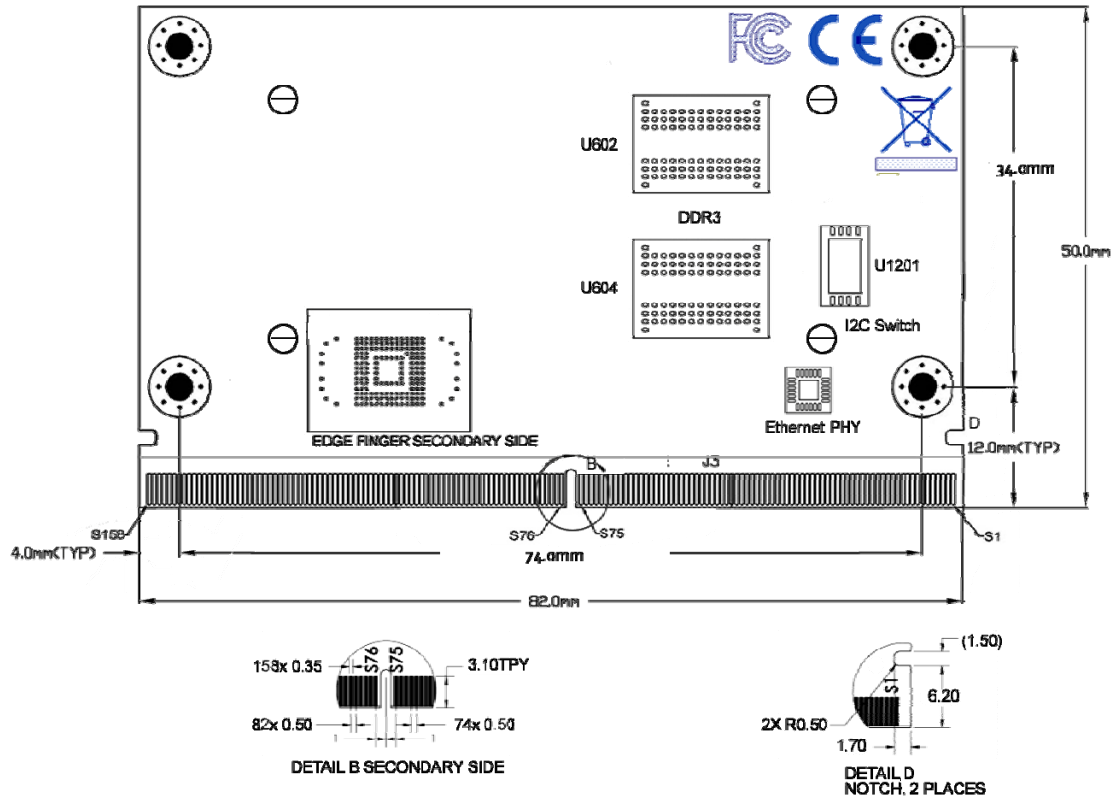

Figure 15. *SMARC-FiMX6* Mechanical Drawings (Top View)



**Figure 16. SMARC-FiMX6 Mechanical Drawings (Bottom View)**

The figure on the following page details the 82mm x 50mm Module mechanical attributes, including the pin numbering and edge finger pattern.

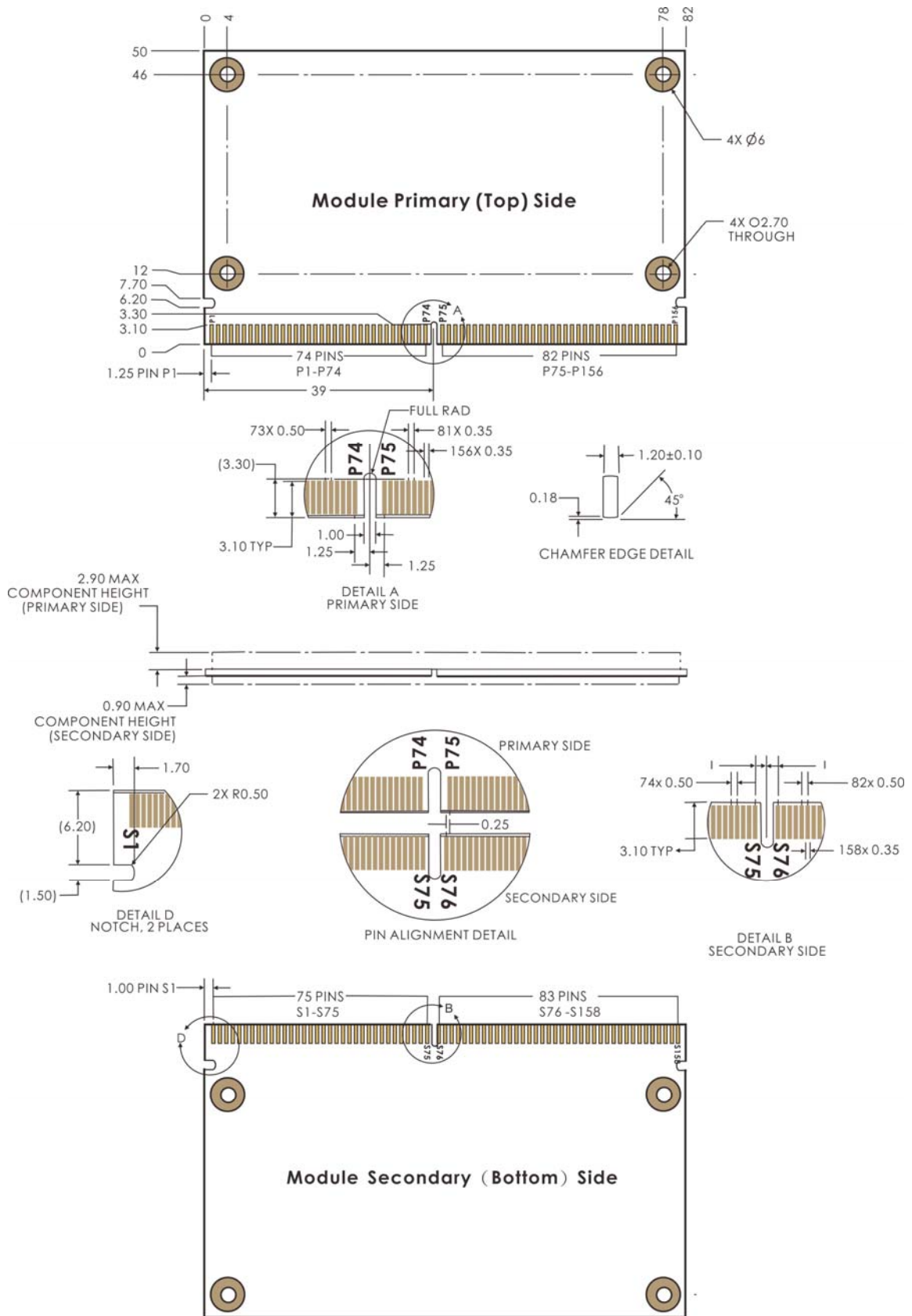

Figure 17: SMARC-FiMX6 Module Mechanical Outline

Top side major component (IC and Connector) information is shown in Figure 18: *SMARC-FiMX6* Top side components.

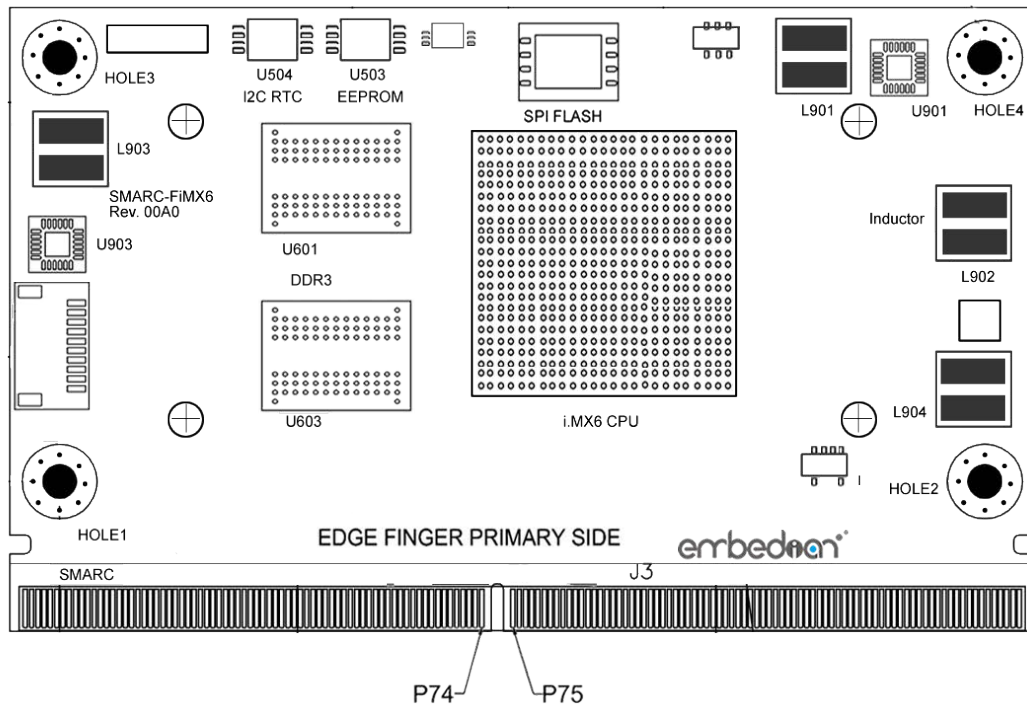
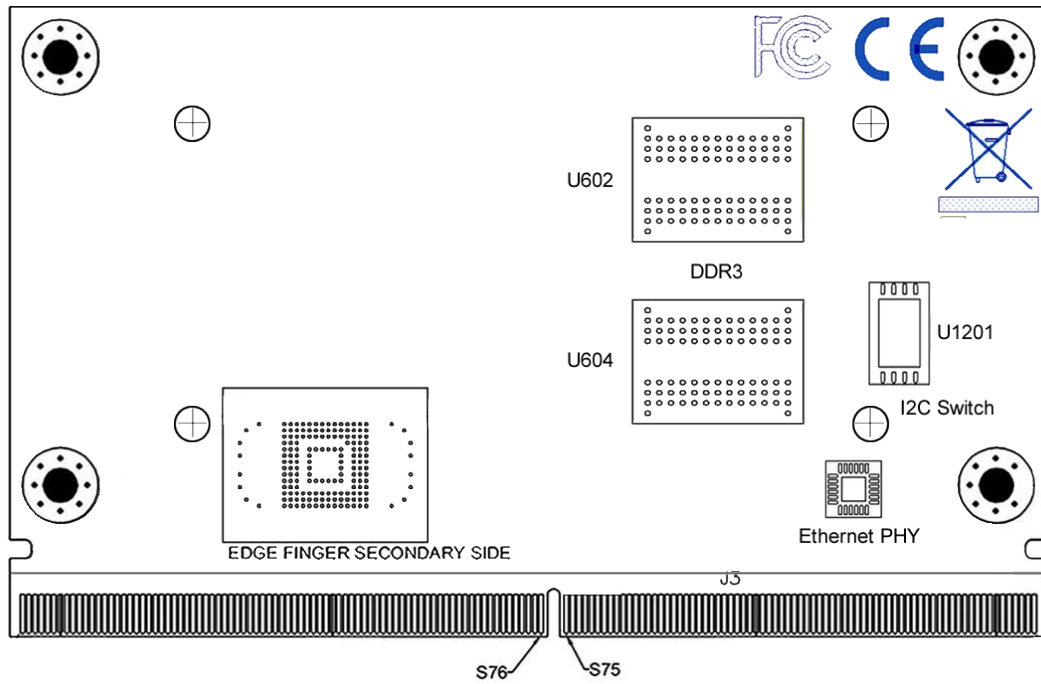

Figure 18. *SMARC-FiMX6* Top Side Components

Bottom side major component (IC and Connector) information is shown in Figure 19: *SMARC-FiMX6* Bottom side components.



**Figure 19. *SMARC-FiMX6* Bottom Side Components**

SMARC-FiMX6 height information from Carrier board Top side to tallest Module component is shown in Figure 20: SMARC-FiMX6 Minimum “Z” Height:

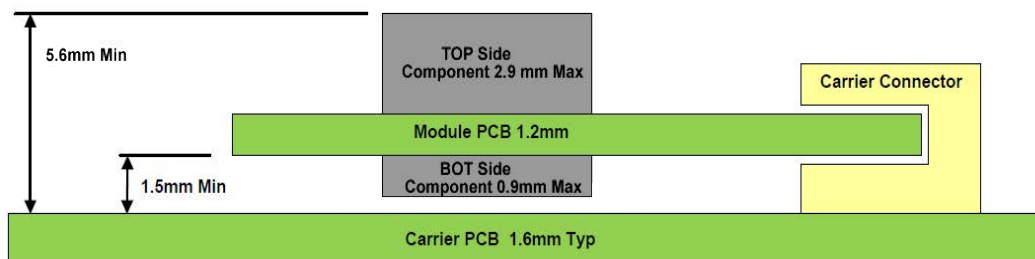

**Figure 20. SMARC-FiMX6 Minimum “Z” Height**

The SMARC connector board-to-board stack heights that are available may result in the use of non-standard spacer lengths. The board-to-board stack heights available include 1.5mm, 2.7mm and 5mm. Of these three, only the spacer for the 5mm stack would likely be a standard length.

When a 1.5mm stack height Carrier board connector is used, there shall not be components on the Carrier board Top side in the Module region. Additionally, when 1.5mm stack height connectors are used, there should not be PCB traces on the Carrier top side in the Module shadow. This is to prevent possible problems with metallic Module heat sink attachment hardware that may protrude through the Module.

If Carrier board components are required in this region, then the Carrier components must be on the Carrier Bottom side, or a taller Module-to-Carrier connector may be used. Stack heights of 2.7mm, 3mm, 5mm and up are available.



### 2.3.5. Carrier Board Connector PCB Footprint

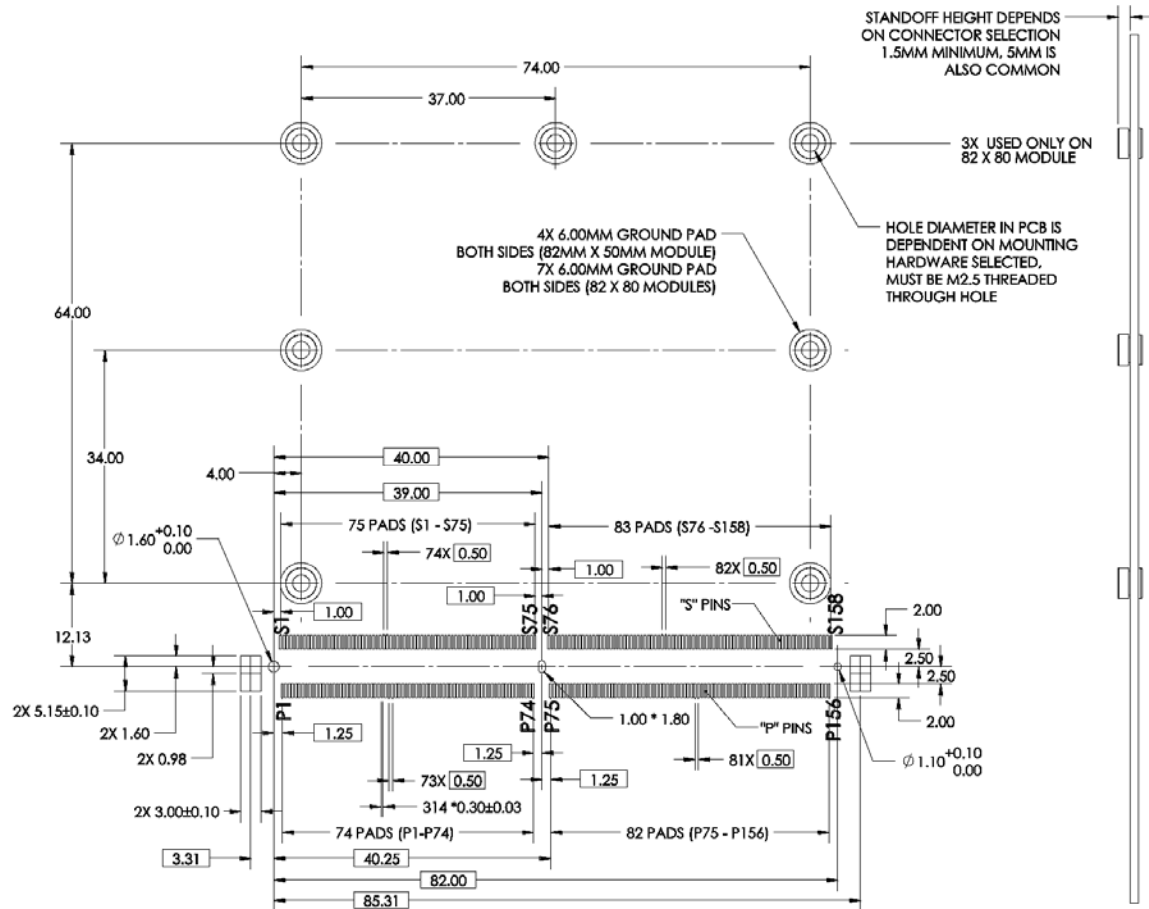

Figure 21: Carrier Board Connector PCB Footprint

**Note:**

The hole diameter for the 4 holes (82mm x 50mm Module) or 7 holes (82mm x 80mm Module) depends on the spacer hardware selection. See the section below for more information on this.

### 2.3.6. Module Assembly Hardware

The *SMARC-FiMX6* module is attached to the carrier with four M2.5 screws. A 4mm length screw is usually used. The attachment holes are located on the corners of the module. Attachment holes have a 6mm diameter pad, 2.7

mm dia drill hole as shown Figure 15: *SMARC-FiMX6* Mechanical Drawings (Top View)

### **2.3.7. Carrier Board Standoffs**

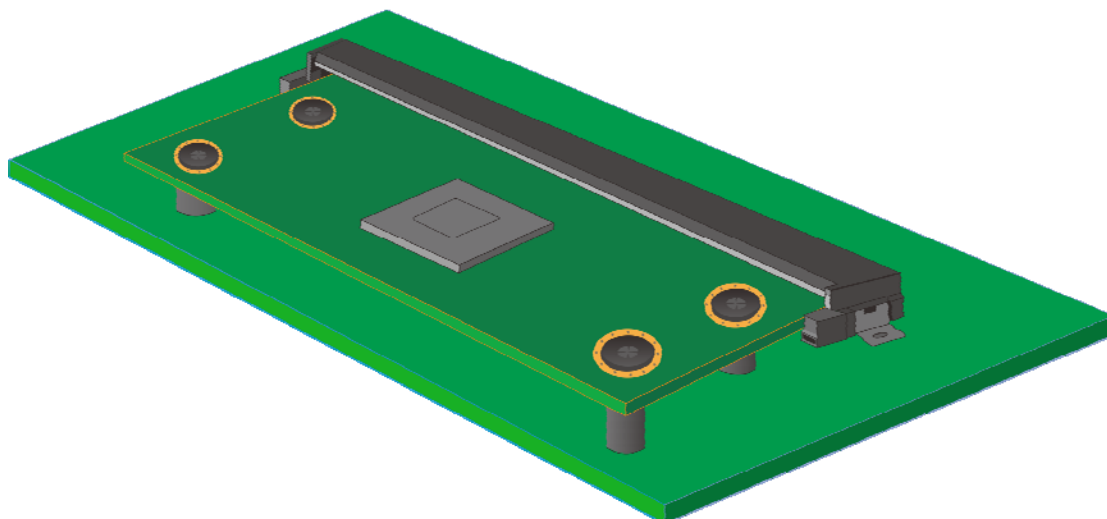

**Figure 22: Screw Fixation**

Standoffs secured to the Carrier board are expected. The standoffs are to be used with M2.5 hardware. Most implementations will use Carrier board standoffs that have M2.5 threads (as opposed to clearance holes). A short M2.5 screw and washer, inserted from the Module top side, secures the Module to the Carrier board threaded standoff.

The *SMARC* connector board-to-board stack heights that are available may result in the use of non-standard spacer lengths. The board-to-board stack heights available include 1.5mm, 2.7mm and 5mm. Of these three, only the spacer for the 5mm stack would likely be a standard length.

Penn Engineering and Manufacturing (PEM) ([www.pemnet.com](http://www.pemnet.com)) makes surface mount spacers with M2.5 internal threads. The product line is called SMTSO (“surface mount technology stand offs”). The shortest standard length offered is 2mm. A custom part with 1.5mm standoff length, M2.5 internal thread, and 5.56mm standoff OD is available from PEM. The Carrier PCB requires a 4.22mm hole and 6.2mm pad to accept these parts.

## *Embedian, Inc.*

Other vendors such as RAF Electronic Hardware ([www.rafhdwe.com](http://www.rafhdwe.com)) offer M2.5 compatible swaged standoffs. Swaged standoffs require the use of a press and anvil at the CM. Their use is common in the industry. The standoff OD and Carrier PCB hole size requirements are different from the PEM SMTSO standoffs described above.

### **2.3.8. Carrier Connector**

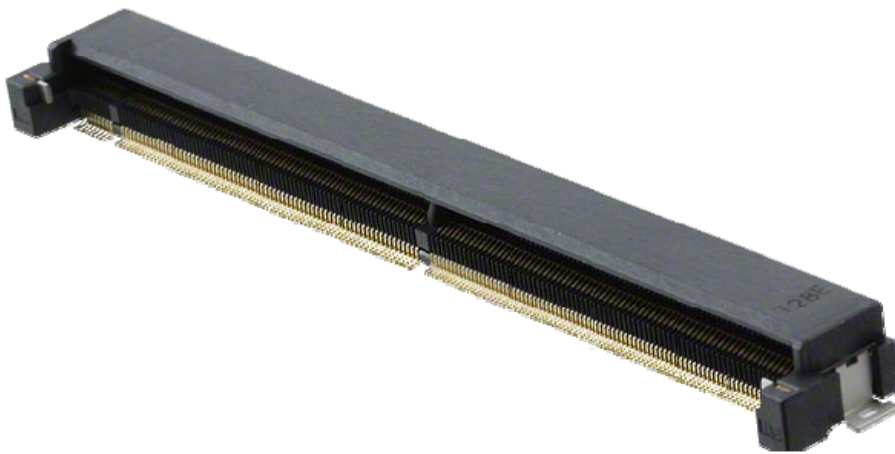

**Figure 23: MXM3 Carrier Connector**

## Embedian, Inc.

The Carrier board connector is a 314 pin 0.5mm pitch right angle part designed for use with 1.2mm thick mating PCBs with the appropriate edge finger pattern. The connector is commonly used for MXM3 graphics cards. The SMARC Module uses the connector in a way quite different from the MXM3 usage.

<i>Vender</i>	<i>Vendor P/N</i>	<i>Stack Height</i>	<i>Body Height</i>	<i>Contact Plating</i>	<i>Pin Style</i>	<i>Body Color</i>
<i>Foxconn</i>	<i>AS0B821-S43B - *H</i>	<i>1.5mm</i>	<i>4.3mm</i>	<i>Flash</i>	<i>Std</i>	<i>Black</i>
<i>Foxconn</i>	<i>AS0B821-S43N - *H</i>	<i>1.5mm</i>	<i>4.3mm</i>	<i>Flash</i>	<i>Std</i>	<i>Ivory</i>
<i>Foxconn</i>	<i>AS0B826-S43B - *H</i>	<i>1.5mm</i>	<i>4.3mm</i>	<i>10 u-in</i>	<i>Std</i>	<i>Black</i>
<i>Foxconn</i>	<i>AS0B826-S43N - *H</i>	<i>1.5mm</i>	<i>4.3mm</i>	<i>10 u-in</i>	<i>Std</i>	<i>Ivory</i>
<i>Lotes</i>	<i>AAA-MXM-008-P04_A</i>	<i>1.5mm</i>	<i>4.3mm</i>	<i>Flash</i>	<i>Std</i>	<i>Tan</i>
<i>Lotes</i>	<i>AAA-MXM-008-P03</i>	<i>1.5mm</i>	<i>4.3mm</i>	<i>15 u-in</i>	<i>Std</i>	<i>Tan</i>
<i>Speedtech</i>	<i>B35P101-02111-H</i>	<i>1.56mm</i>	<i>4.0mm</i>	<i>Flash</i>	<i>Std</i>	<i>Black</i>
<i>Speedtech</i>	<i>B35P101-02011-H</i>	<i>1.56mm</i>	<i>4.0mm</i>	<i>Flash</i>	<i>Std</i>	<i>Tan</i>
<i>Speedtech</i>	<i>B35P101-02112-H</i>	<i>1.56mm</i>	<i>4.0mm</i>	<i>10 u-in</i>	<i>Std</i>	<i>Black</i>
<i>Speedtech</i>	<i>B35P101-02012-H</i>	<i>1.56mm</i>	<i>4.0mm</i>	<i>10 u-in</i>	<i>Std</i>	<i>Tan</i>
<i>Speedtech</i>	<i>B35P101-02113-H</i>	<i>1.56mm</i>	<i>4.0mm</i>	<i>15 u-in</i>	<i>Std</i>	<i>Black</i>
<i>Speedtech</i>	<i>B35P101-02013-H</i>	<i>1.56mm</i>	<i>4.0mm</i>	<i>15 u-in</i>	<i>Std</i>	<i>Tan</i>
<i>Aces</i>	<i>91781-314 2 8-001</i>	<i>2.7mm</i>	<i>5.2mm</i>	<i>3 u-in</i>	<i>Std</i>	<i>Black</i>

<i>Vender</i>	<i>Vendor P/N</i>	<i>Stack Height</i>	<i>Body Height</i>	<i>Contact Plating</i>	<i>Pin Style</i>	<i>Body Color</i>
<i>Foxconn</i>	<i>AS0B821-S55B - *H</i>	<i>2.7mm</i>	<i>5.5mm</i>	<i>Flash</i>	<i>Std</i>	<i>Black</i>
<i>Foxconn</i>	<i>AS0B821-S55N - *H</i>	<i>2.7mm</i>	<i>5.5mm</i>	<i>Flash</i>	<i>Std</i>	<i>Ivory</i>
<i>Foxconn</i>	<i>AS0B826-S55B - *H</i>	<i>2.7mm</i>	<i>5.5mm</i>	<i>10 u-in</i>	<i>Std</i>	<i>Black</i>
<i>Foxconn</i>	<i>AS0B826-S55N - *H</i>	<i>2.7mm</i>	<i>5.5mm</i>	<i>10 u-in</i>	<i>Std</i>	<i>Ivory</i>
<i>Speedtech</i>	<i>B35P101-02121-H</i>	<i>2.76mm</i>	<i>5.2mm</i>	<i>Flash</i>	<i>Std</i>	<i>Black</i>
<i>Speedtech</i>	<i>B35P101-02021-H</i>	<i>2.76mm</i>	<i>5.2mm</i>	<i>Flash</i>	<i>Std</i>	<i>Tan</i>
<i>Speedtech</i>	<i>B35P101-02122-H</i>	<i>2.76mm</i>	<i>5.2mm</i>	<i>10 u-in</i>	<i>Std</i>	<i>Black</i>
<i>Speedtech</i>	<i>B35P101-02022-H</i>	<i>2.76mm</i>	<i>5.2mm</i>	<i>10 u-in</i>	<i>Std</i>	<i>Tan</i>
<i>Speedtech</i>	<i>B35P101-02123-H</i>	<i>2.76mm</i>	<i>5.2mm</i>	<i>15 u-in</i>	<i>Std</i>	<i>Black</i>
<i>Speedtech</i>	<i>B35P101-02023-H</i>	<i>2.76mm</i>	<i>5.2mm</i>	<i>15 u-in</i>	<i>Std</i>	<i>Tan</i>
<i>Foxconn</i>	<i>AS0B821-S78B - *H</i>	<i>5.0mm</i>	<i>7.8mm</i>	<i>Flash</i>	<i>Std</i>	<i>Black</i>
<i>Foxconn</i>	<i>AS0B821-S78N - *H</i>	<i>5.0mm</i>	<i>7.8mm</i>	<i>Flash</i>	<i>Std</i>	<i>Ivory</i>
<i>Foxconn</i>	<i>AS0B826-S78B - *H</i>	<i>5.0mm</i>	<i>7.8mm</i>	<i>10 u-in</i>	<i>Std</i>	<i>Black</i>
<i>Foxconn</i>	<i>AS0B826-S78N - *H</i>	<i>5.0mm</i>	<i>7.8mm</i>	<i>10 u-in</i>	<i>Std</i>	<i>Ivory</i>
<i>Yamaichi<sup>(1)</sup></i>	<i>CN113-314-2001</i>	<i>5.0mm</i>	<i>7.8mm</i>	<i>0.3 u-meter</i>	<i>Std</i>	<i>Black</i>

Other, taller stack heights may be available from these and other vendors. Stack heights as tall as 11mm are shown on the Aces web site.

**Note:**

1. *Yamaichi CN113-314-2001* is automotive grade.
2. The vendor drawings for the connectors listed above show a PCB footprint pattern for use with an MXM3 graphics card. This footprint, and the associated pin numbering, is not suitable for SMARC use. The

MXM3 standard gangs large groups of pins together to provide ~80W capable power paths needed for X86 graphics cards. The *SMARC* module “ungangs” these pins to allow more signal pins. Footprint and pin numbering information for application of this 314 pin connector to *SMARC* is given in the sections below.

### **2.3.9. Module Cooling Solution—Heat Spreader**

A standard heat-spreader plate for use with the *SMARC* 82mm x 50mm form factor is described below. A standard heat spreader plate definition allows the customer to use a Module from multiple vendors.

The heat spreader plate is sized at 82mm x 42mm x 3mm, and sits 3mm above the *SMARC* Module. The heat spreader plate ‘Y’ dimension is deliberately set at 42mm and not 50mm, to allow the plate to clear the *SMARC* MXM3 connector. The plate is shown in the figures below.

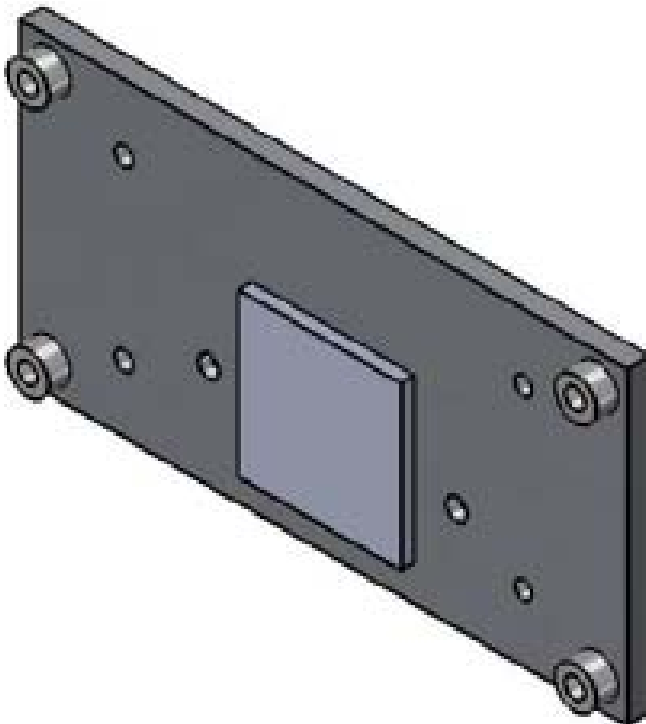

**Figure 24: Heat Spreader**

*Embedian, Inc.*

The internal square in the figure above is a thermally conductive and mechanically compliant Thermal Interface Material (or “TIM”). The exact X-Y position and Z thickness details of the TIM vary from design to design.

The two holes immediately adjacent to the TIM serve to secure the PCB in the SOC area and compress the TIM.

The four interior holes that are further from the center allow a heat sink to be attached to the heat spreader plate, or they can be used to secure the heat spreader plate to a chassis wall that serves as a heat sink.

Dimensions and further details may be found in the following figure.

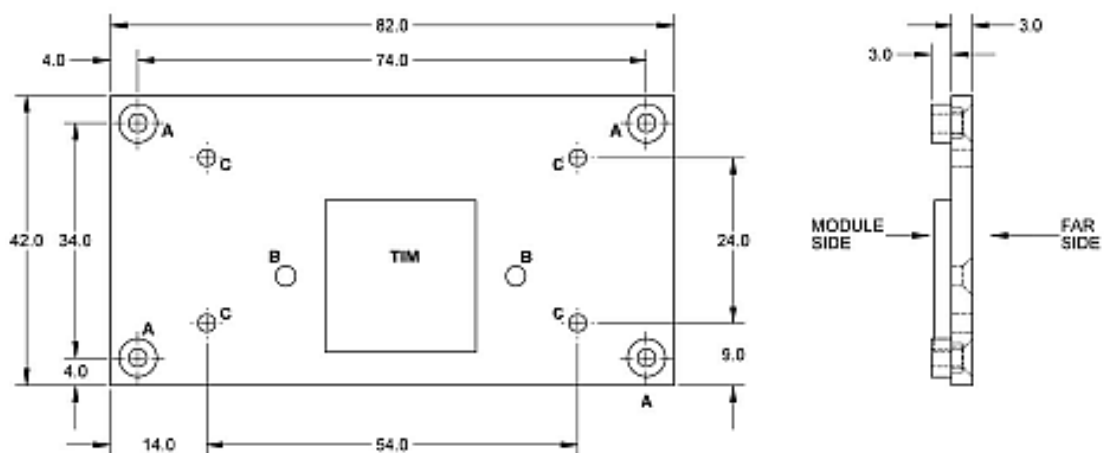

Dimensions in the figure above are in millimeters. “TIM” stands for “Thermal Interface Material”. The TIM takes up the small gap between the SOC top and the Module - facing side of the heat spreader.

<b>Hole Reference</b>	<b>Description</b>	<b>Size</b>
<b>A</b>	<p><i>SMARC Module corner mounting holes Spacing determined by SMARC specification for 82mm x 50mm Modules.</i></p> <p><i>Typically these holes have 3mm length press fit or swaged clearance standoffs on the Module side.</i></p> <p><i>These holes are typically countersunk on the far side of the plate, to allow the heat spreader plate to be flush with a secondary heat sink.</i></p>	<p><i>Hole size depends on standoffs used. Standoff diameter must be compatible with SMARC Module mounting hole pad and hole size (6.0mm pads, 2.7mm holes on the Module). The holes and standoffs are for use with M2.5 screw hardware.</i></p> <p><i>The far side of these holes are counter-sunk to allow the attachment screw to be flush with the far side heat spreader surface.</i></p>
<b>B</b>	<i>Not Defined</i>	
<b>C</b>	<p><i>Fixed location holes to allow the attachment of a heat sink to the heat spreader, or to allow the heat spreader to be secured to a chassis wall that can serve as a heat sink.</i></p>	<i>M3 threaded holes</i>



## **2.4 Electrical Specifications**

### **2.4.1. Supply Voltage**

The *SMARC-FiMX6* module operates over an input voltage range of 3.0V to 5.25V. Power is provided from the carrier through 10 power pins as defined by the *SMARC* specification.

**Caution!** A single 5V DC input is recommended.

### **2.4.2. RTC/Backup Voltage**

3.0V RTC backup power is provided through the VDD\_RTC pin from the carrier board. This connection provides back up power to the module PMIC. The RTC is powered via the primary system 3.3V supply during normal operation and via the VBAT power input, if it is present, during power-off.

### **2.4.3. No Separate Standby Voltage**

The *SMARC-FiMX6* does not have a standby power rail. Standby operation is powered through the main supply voltage rail, as defined in the *SMARC* specification.

### **2.4.4. Module I/O Voltage**

The *SMARC-FiMX6* module supports 1.8V (*SMARC* v1.1 compliant) or 3.3V (*SMARC* v1.0 compliant) level I/O voltage depending on the part number that users selected.

### **2.4.5. MTBF**

The *SMARC-FiMX6* System MTBF (hours) : >100,000 hours

## *Embedian, Inc.*

The above MTBF (Mean Time Between Failure) values were calculated using a combination of manufacturer's test data, if the data was available, and a Bellcore calculation for the remaining parts. The Bellcore calculation used is "Method 1 Case 1". In that particular method the components are assumed to be operating at a 50 % stress level in a 40° C ambient environment and the system is assumed to have not been burned in. Manufacturer's data has been used wherever possible. The manufacturer's data, when used, is specified at 50°C, so in that sense the following results are slightly conservative. The MTBF values shown below are for a 40°C in an office or telecommunications environment. Higher temperatures and other environmental stresses (extreme altitude, vibration, salt water exposure, etc.) lower MTBF values.

### **2.4.6. Power Consumption**

The power consumption values listed in this document were measured under a controlled environment. The hardware used for testing includes an *SMARC-FiMX6* module, carrier board for *SMARC* ARM, TFT monitor, micro-SD card and USB keyboard. The carrier board was powered externally by a power supply unit so that it does not influence the power consumption value that is measured for the module. The USB keyboard was detached once the module was configured within the OS. All recorded values were averaged over a 30 second time period. The modules were cooled by the heatspreader specific to the module variants.

Each module was measured while running 32 bit Linaro Ubuntu 14.04. To measure the worst case power consumption, the cooling solution was removed and the CPU core temperature was allowed to run between 95° and 100°C at 100% workload. The peak current value was then recorded. This value should be taken into consideration when designing the system's power supply to ensure that the power supply is sufficient during worst case scenarios.

Power consumption values were recorded during the following stages:  
Linaro Ubuntu 14.04 (32 bit)

- Desktop Idle
- 100% CPU workload
- 100% CPU workload at approximately 100°C peak power consumption

**Note:** With the linux stress tool, we stressed the CPU to maximum frequency.

## Embedian, Inc.

The table below provides additional information about the different variants offered by the *SMARC-FiMX6*.

### 2.4.6.1. Freescale *i.MX6* Cortex A9 1GHz Solo Core 512KB L2

**Cache** With 8GB onboard eMMC.

<i>P/N: SMARC-FiMX6-S</i>	<i>Freescale i.MX6 Cortex A9 1GHz Solo Core 512KB L2 Cache</i>		
<i>Memory Size</i>	512MB		
<i>Operating System</i>	Ubuntu 14.04		
<i>Power States</i>	<i>Desktop Idle</i>	<i>100% workload</i>	<i>Max. power consumption</i>
<i>Power Consumption (Amp/Watts)</i>	0.22A/1.1W	0.31A/1.55W	0.42A/2.1W

### 2.4.6.2. Freescale *i.MX6* Cortex A9 1GHz Dual Lite Core 512KB L2

**Cache**

With 8GB onboard eMMC.

<i>P/N: SMARC-FiMX6-U</i>	<i>Freescale i.MX6 Cortex A9 1GHz Dual Lite Core 512KB L2 Cache</i>		
<i>Memory Size</i>	1GB		
<i>Operating System</i>	Ubuntu 14.04		
<i>Power States</i>	<i>Desktop Idle</i>	<i>100% workload</i>	<i>Max. power consumption</i>
<i>Power Consumption (Amp/Watts)</i>	0.26A/1.3W	0.44A/2.2W	0.66A/3.3W

**2.4.6.3. Freescale i.MX6 Cortex A9 1GHz Dual Core 1MB L2**

**Cache** With 8GB onboard eMMC.

<i>P/N: SMARC-FiMX6-D-1G</i>	<i>Freescale i.MX6 Cortex A9 1GHz Dual Core 1MB L2 Cache</i>		
<i>Memory Size</i>	<i>1GB</i>		
<i>Operating System</i>	<i>Ubuntu 14.04</i>		
<i>Power States</i>	<i>Desktop Idle</i>	<i>100% workload</i>	<i>Max. power consumption</i>
<i>Power Consumption (Amp/Watts)</i>	<i>0.28A/1.4W</i>	<i>0.5A/2.5W</i>	<i>0.7A/3.5W</i>

**2.4.6.4. Freescale i.MX6 Cortex A9 1GHz Quad Core 1MB L2**

**Cache** With 8GB onboard eMMC.

<i>P/N: SMARC-FiMX6-Q-1G</i>	<i>Freescale i.MX6 Cortex A9 1GHz Quad Core 1MB L2 Cache</i>		
<i>Memory Size</i>	<i>1GB</i>		
<i>Operating System</i>	<i>Ubuntu 14.04</i>		
<i>Power States</i>	<i>Desktop Idle</i>	<i>100% workload</i>	<i>Max. power consumption</i>
<i>Power Consumption (Amp/Watts)</i>	<i>0.3A/1.5W</i>	<i>0.72A/3.6W</i>	<i>0.92A/4.6W</i>

#### **2.4.6.5. Freescale i.MX6 Cortex A9 1GHz Dual Core 1MB L2**

**Cache** With 8GB onboard eMMC.

<b>P/N: SMARC-FiMX6-D-2G</b>	<b>Freescale i.MX6 Cortex A9 1GHz Quad Core 1MB L2 Cache</b>		
<i>Memory Size</i>	2GB		
<i>Operating System</i>	Ubuntu 14.04		
<i>Power States</i>	<i>Desktop Idle</i>	<i>100% workload</i>	<i>Max. power consumption</i>
<i>Power Consumption (Amp/Watts)</i>	0.28A/1.4W	0.52A/2.6W	0.72A/3.6W

#### **2.4.6.6. Freescale i.MX6 Cortex A9 1GHz Quad Core 1MB L2**

**Cache** With 8GB onboard eMMC.

<b>P/N: SMARC-FiMX6-Q-2G</b>	<b>Freescale i.MX6 Cortex A9 1GHz Quad Core 1MB L2 Cache</b>		
<i>Memory Size</i>	2GB		
<i>Operating System</i>	Ubuntu 14.04		
<i>Power States</i>	<i>Desktop Idle</i>	<i>100% workload</i>	<i>Max. power consumption</i>
<i>Power Consumption (Amp/Watts)</i>	0.3A/1.5W	0.74A/3.7W	0.94A/4.7W

## **2.5 Environmental Specifications**

### **2.5.1. Operating Temperature**

The *SMARC-FiMX6* module operates from 0°C to 60°C air temperature, without a passive heat sink arrangement. Industrial temperature (-40°C ~85°C is also available with different part number *SMARC-FiMX6-I*).

### **2.5.2. Humidity**

Operating: 10% to 90% RH (non-condensing).  
Non-operating: 5% to 95% RH (non-condensing).

### **2.5.3. ROHS/REACH Compliance**

The *SMARC-FiMX6* module is compliant to the 2002/95/EC *RoHS* directive and *REACH* directive.

# Chapter 3

## Connector PinOut

This Chapter gives detail pinout of *SMARC-FiMX6* golden finger edge connector.

Section include :

- *SMARC-FiMX6* Connector Pin Mapping

## Chapter 3 Connector Pinout

The Module pins are designated as P1 – P156 on the Module Primary (Top) side, and S1 – S158 on the Module Secondary (Bottom) side. There are total of 314 pins on the Module. The connector is sometimes identified as a 321 pin connector, but 7 pins are lost to the key (4 on the primary side and 3 on secondary side).

The Secondary (Bottom) side faces the Carrier board when a normal or standard Carrier connector is used.

The *SMARC-FiMX6* module pins are deliberately numbered as P1 – P156 and S1 – S158 for clarity and to differentiate the *SMARC* Module from *MXM3* graphics modules, which use the same connector but use the pins for very different functions. *MXM3* cards and *MXM3* baseboard connectors use different pin numbering scheme.

### 3.1 SMARC-FiMX6 Connector Pin Mapping

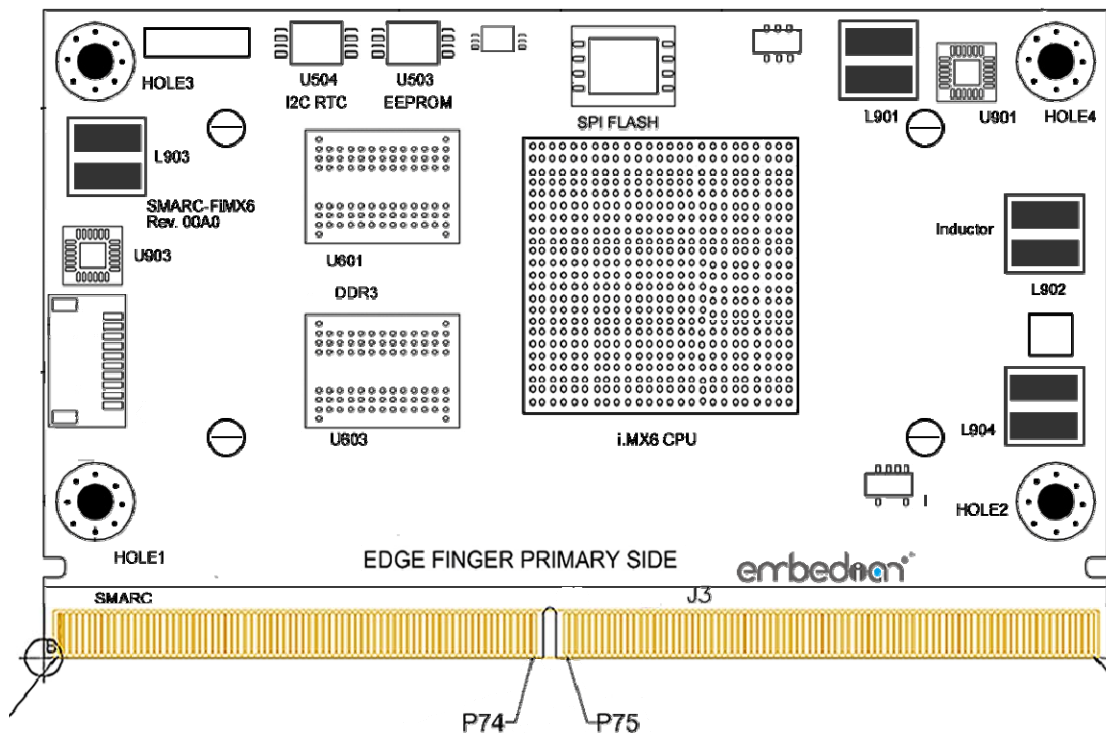

Figure 25: SMARC-FiMX6 edge finger primary pins



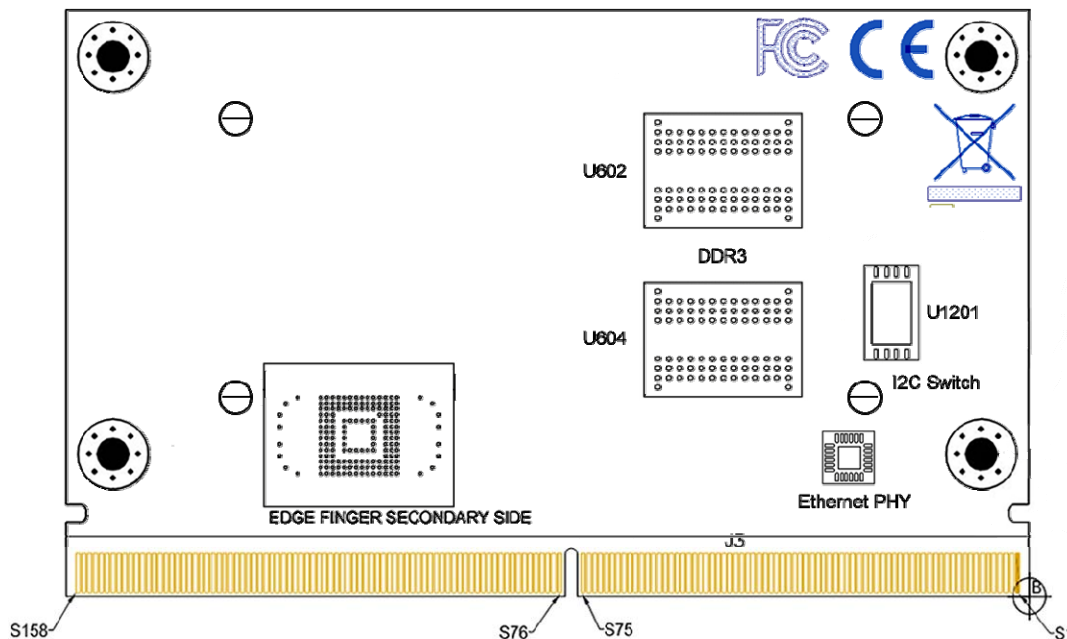

Figure 26: SMARC-FiMX6 edge finger secondary pins

The next tables describe each pin, its properties, and its use on the module and development board.

The “SMARC Edge Finger” column shows the connection of the signals defined in the SMARC specification. The “Freescale i.MX6 CPU” column shows the connection of the CPU signals on the module. The format of this column is “Ball/Mode/Signal Name” where “Signal Name” is the chip where the signals are connected, and “Ball” is the name of the pad where the signals are connected as they are defined in the i.MX6 processor datasheet.

### Pinout Legend

<b>I</b>	<i>Input</i>
<b>O</b>	<i>Output</i>
<b>I/O</b>	<i>Input or output</i>
<b>P</b>	<i>Power</i>
<b>AI</b>	<i>Analogue input</i>
<b>AO</b>	<i>Analogue output</i>
<b>AIO</b>	<i>Analogue Input or analogue output</i>
<b>OD</b>	<i>Open Drain Signal</i>
<b>#</b>	<i>Low level active signal</i>

SMARC Edge Finger		Freescale i.MX6 CPU			Type	Description
Pin#	Pin Name	Ball	Mode	Signal Name		
P1	PCAM_PXL_CK1					Not used
P2	GND				P	Ground
P3	CSI1_CK+ / PCAM_D0	F3		CSI_CLK0P	I	CSI1 differential clock inputs
P4	CSI1_CK- / PCAM_D1	F4		CSI_CLK0M	I	CSI1 differential clock inputs
P5	PCAM_DE					Not used
P6	PCAM_MCK					Not used
P7	CSI1_D0+ / PCAM_D2	E3		CSI_D0P	I	CSI1 differential data inputs
P8	CSI1_D0- / PCAM_D3	E4		CSI_D0M	I	CSI1 differential data inputs
P9	GND				P	Ground
P10	CSI1_D1+ / PCAM_D4	D2		CSI_D1P	I	CSI1 differential data inputs
P11	CSI1_D1- / PCAM_D5	D1		CSI_D1M	I	CSI1 differential data inputs
P12	GND				P	Ground
P13	CSI1_D2+ / PCAM_D6	E2		CSI_D2P	I	CSI1 differential data inputs
P14	CSI1_D2- / PCAM_D7	E1		CSI_D2M	I	CSI1 differential data inputs
P15	GND				P	Ground
P16	CSI1_D3+ / PCAM_D8	F1		CSI_D3P	I	CSI1 differential data inputs
P17	CSI1_D3- / PCAM_D9	F2		CSI_D3M	I	CSI1 differential data inputs
P18	GND				P	Ground

SMARC Edge Finger		Freescale i.MX6 CPU			Type	Description
Pin#	Pin Name	Ball	Mode	Signal Name		
P19	GbE_MDI3-	--	--	--	AIO	Qualcomm AR8035 Differential Transmit/Receive Negative Channel 3
P20	GbE_MDI3+	--	--	--	AIO	Qualcomm AR8035 Differential Transmit/Receive Positive Channel 3
P21	GbE_LINK100#	--	--	--	O OD	Link Speed Indication LED for 100Mbps Could be able to sink 24mA or more Carrier LED current
P22	GbE_LINK1000#	--	--	--	O OD	Link Speed Indication LED for 1000Mbps Could be able to sink 24mA or more Carrier LED current
P23	GbE_MDI2-	--	--	--	AIO	Qualcomm AR8035 Differential Transmit/Receive Negative Channel 2
P24	GbE_MDI2+	--	--	--	AIO	Qualcomm AR8035 Differential Transmit/Receive Positive Channel 2
P25	GbE_LINK_ACT#	--	--	--	O OD	Link / Activity Indication LED Driven low on Link (10, 100 or 1000 mbps) Blinks on Activity Could be able to sink 24mA or more Carrier LED current

SMARC Edge Finger		Freescale i.MX6 CPU			Type	Description
Pin#	Pin Name	Ball	Mode	Signal Name		
P26	GbE_MDI1-	--	--	--	AIO	Qualcomm AR8035 Differential Transmit/Receive Negative Channel 1
P27	GbE_MDI1+	--	--	--	AIO	Qualcomm AR8035 Differential Transmit/Receive Positive Channel 1
P28	GbE_CTREF	--	--	--	0	Qualcomm AR8035 Center tap reference voltage for GBE Carrier board Ethernet magnetic
P29	GbE_MDI0-	--	--	--	AIO	Qualcomm AR8035 Differential Transmit/Receive Negative Channel 0
P30	GbE_MDI0+	--	--	--	AIO	Qualcomm AR8035: Differential Transmit/Receive Positive Channel 0

SMARC Edge Finger		Freescale i.MX6 CPU			Type	Description
Pin#	Pin Name	Ball	Mode	Signal Name		
P31	SPI0_CS1#	G22	ALT5	EIM_D25__ GPIO3_I025	O	SPI0 Master Chip Select 1 output.
P32	GND				P	Ground
P33	SDIO_WP	U21	ALT0	ENET_CRS_DV__ GPIO1_I025	I	Write Protect
P34	SDIO_CMD	F19	ALT0	SD2_CMD__ SD2_CMD	IO	Command Line
P35	SDIO_CD#	V21	ALT5	ENET_TX_EN__ GPIO1_I028	I	Card Detect
P36	SDIO_CLK	C21	ALT0	SD2_CLK__ SD2_CLK	O	Clock
P37	SDIO_PWR_EN	B21	ALT5	ENET_TX_EN__ GPIO1_I028	O	SD card power enable
P38	GND				P	Ground
P39	SDIO_D0	A22	ALT0	SD2_DAT0__ SD2_DATA0	IO	Data path
P40	SDIO_D1	E20	ALT0	SD2_DAT1__ SD2_DATA1	IO	Data path
P41	SDIO_D2	A23	ALT0	SD2_DAT3__ SD2_DATA3	IO	Data path
P42	SDIO_D3	B22	ALT0	SD2_DAT3__ SD2_DATA3	IO	Data path
P43	SPI0_CS0#	F22	ALT5	EIM_D24__ GPIO3_I024	O	SPI0 Master Chip Select 0 output, reserved for on-module NOR flash
P44	SPI0_CLK	N6	ALT2	CSI0_DAT8__ ECSPI2_SCLK	O	SPI0 Master Clock output
P45	SPI0_DIN	M1	ALT2	CSI0_DAT10__E CSPI2_MISO	I	SPI0 Master Data input (input to CPU, output from SPI device)

SMARC Edge Finger		Freescale i.MX6 CPU			Type	Description
Pin#	Pin Name	Ball	Mode	Signal Name		
P46	SPI0_DO	N5	ALT2	CSI0_DAT9__ ECSPI2_MOSI	O	SPI0 Master Data output (output from CPU, input to SPI device)
P47	GND				P	Ground
P48	SATA_TX+	A12		SATA_TXP	O	Transmit Output differential pair.
P49	SATA_TX-	B12		SATA_TXM	O	Transmit Output differential pair.
P50	GND				P	Ground
P51	SATA_RX+	B14		SATA_RXP	I	Receive Input differential pair
P52	SATA_RX-	A14		SATA_RXM	I	Receive Input differential pair
P53	GND				P	Ground
P54	SPI1_CS0#	U6	ALT5	KEY_ROW1__ GPIO4_I009	O	SPI1 Master Chip Select 0 output
P55	SPI1_CS1#	W6	ALT5	KEY_COL2__ GPIO4_I010	O	SPI1 Master Chip Select 1 output
P56	SPI1_CK	W5	ALT0	KEY_COL0__ ECSPI1_SCLK	O	SPI1 Master Clock output
P57	SPI1_DIN	U7	ALT0	KEY_COL1__ ECSPI1_MISO	I	SPI1 Master Data input (input to CPU, output from SPI device)
P58	SPI1_DO	V6	ALT0	KEY_ROW0__ ECSPI1_MOSI	O	SPI1 Master Data output (output from CPU, input to SPI device)
P59	GND				P	Ground

SMARC Edge Finger		Freescale i.MX6 CPU			Type	Description
Pin#	Pin Name	Ball	Mode	Signal Name		
P60	USB0+	N17	Mode0	USB0_DP	IO	Differential USB0 data
P61	USB0-	N18	Mode0	USB0_DM	IO	Differential USB0 data
P62	USB0_EN_OC#	U20 W20	ALT5 ALT5	ENET_TXD0__ GPIO1_I030 ENET_TXD1__ GPIO1_I029	IO OD	Pulled low by Module OD driver to disable USB0 power Pulled low by Carrier OD driver to indicate over-current situation If this signal is used, a pull-up is required on the Carrier
P63	USB0_VBUS_DET	E9		Turn on USB_OTG_VBUS	I	USB host power detection, when this port is used as a device
P64	USB0_OTG_ID	W23	ALT0	ENET_RX_ER__ USB_OTG_ID	I	USB OTG ID input, active high
P65	USB1+	E10		USB_H1_DP	IO	Differential USB0 data pair
P66	USB1-	F10		USB_H1_DN	IO	

SMARC Edge Finger		Freescale i.MX6 CPU			Type	Description
Pin#	Pin Name	Ball	Mode	Signal Name		
P67	USB1_EN_OC#	W21	ALT5	ENET_RXD0__ GPIO1_I027	IO OD	Pulled low by Module OD driver to disable USB0 power Pulled low by Carrier OD driver to indicate over-current situation If this signal is used, a pull-up is required on the Carrier
		W22	ALT5	ENET_RXD1__ GPIO1_I026		
P68	GND				P	Ground
P69	USB2+					Not used
P70	USB2-					Not used
P71	USB2_EN_OC#					Not used
P72	PCIE_C_PRSENT#					Not used
P73	PCIE_B_PRSENT#					Not used
P74	PCIE_A_PRSENT#	C20	ALT5	SD1_DAT1__ GPIO1_I017	I	PCIe Port A present input
P75	PCIE_A_RST#	D20	ALT5	SD1_CLK__ GPIO1_I020	O	Reset Signal for external devices.
P76	PCIE_C_CKREQ#					Not used
P77	PCIE_B_CKREQ#					Not used
P78	PCIE_A_CKREQ#	A21	ALT5	SD1_DAT0__ GPIO1_I016	I	PCIe Port A clock request input
P79	GND				P	Ground
P80	PCIE_C_REFCK+					Not used



SMARC Edge Finger		Freescale i.MX6 CPU			Type	Description
Pin#	Pin Name	Ball	Mode	Signal Name		
P81	PCIE_C_REFCK-					Not used
P82	GND				P	Ground
P83	PCIE_A_REFCK+	D7		CLK1_P	O	Differential PCI Express Reference Clock Signals for Lanes A
P84	PCIE_A_REFCK-	C7		CLK1_N	O	Differential PCI Express Reference Clock Signals for Lanes A
P85	GND				P	
P86	PCIE_A_RX+	B2		PCIE_RXP	I	Differential PCIe Link A receive data pair 0
P87	PCIE_A_RX-	B1		PCIE_RXM	I	Differential PCIe Link A receive data pair 0
P88	GND				P	Ground
P89	PCIE_A_TX+	B3		PCIE_TXP	O	Differential PCIe Link A transmit data pair 0
P90	PCIE_A_TX-	A3		PCIE_TXM	O	Differential PCIe Link A transmit data pair 0
P91	GND				P	Ground
P92	HDMI_D2+	K4	N/A	HDMI_D2P	O	TMDS / HDMI data differential pair 2
P93	HDMI_D2-	K3	N/A	HDMI_D2M	O	TMDS / HDMI data differential pair 2

SMARC Edge Finger		Freescale i.MX6 CPU			Type	Description
Pin#	Pin Name	Ball	Mode	Signal Name		
P94	GND				P	Ground
P95	HDMI_D1+	J4	N/A	HDMI_D1P	O	TMDS / HDMI data differential pair 1
P96	HDMI_D1-	J3	N/A	HDMI_D1M	O	TMDS / HDMI data differential pair 1
P97	GND				P	Ground
P98	HDMI_D0+	K6	N/A	HDMI_D0P	O	TMDS / HDMI data differential pair 0
P99	HDMI_D0-	K5	N/A	HDMI_D0M	O	TMDS / HDMI data differential pair 0
P100	GND				P	Ground
P101	HDMI_CK+	J6	N/A	HDMI_CLKP	O	HDMI differential clock output pair
P102	HDMI_CK-	J5	N/A	HDMI_CLKM	O	HDMI differential clock output pair
P103	GND				P	Ground
P104	HDMI_HPD	K1	N/A	HDMI_HPD	I	HDMI Hot Plug Detect input
P105	HDMI_CTRL_CK	U5	ALT4	KEY_COL3__ I2C2_SCL	IO OD	I2C Clock
P106	HDMI_CTRL_DAT	T7	ALT4	KEY_ROW3__ I2C2_SDA	IO OD	I2C Data

SMARC Edge Finger		Freescale i.MX6 CPU			Type	Description
Pin#	Pin Name	Ball	Mode	Signal Name		
P107	HDMI_CEC	K2	N/A	HDMI_DDCCE C	IO  OD	HDMI Consumer Electronics Control  1 – wire peripheral control interface
P108	GPI00 / CAM0_PWR#	F15	ALT5	NANDF_CS0_ _GPI06_I011	IO	Camera 0 Power Enable, active low output
P109	GPI01 / CAM1_PWR#	F16	ALT5	NANDF_D2_ GPI02_I002	IO	Camera 1 Power Enable, active low output
P110	GPI02 / CAM0_RST#	E17	ALT5	NANDF_D6_ GPI02_I006	IO	Camera 0 Reset, active low output
P111	GPI03 / CAM1_RST#	D17	ALT5	NANDF_D3_ GPI02_I003	IO	Camera 1 Reset, active low output
P112	GPI04 / HDA_RST#	C18	ALT5	NANDF_D7 GPI02_I007	IO	HD Audio Reset, active low output
P113	GPI05 / PWM_OUT	F18	ALT5	SD1_DAT3_ GPI01_I021	IO	PWM output
P114	GPI06 / TACHIN	C16	ALT5	NANDF_CS1_ GPI06_I014	IO	Tachometer input (used with the GPI05 PWM)
P115	GPI07 / PCAM_FLD	C15	ALT5	NANDF_CLE_ GPI06_I007	IO	PCAM_FLD (Field) signal input
P116	GPI08 / CAN0_ERR#	A19	ALT5	NANDF_D4_ GPI02_I004	IO	CAN0 Error signal, active low input
P117	GPI09 / CAN1_ERR#	A18	ALT5	NANDF_D0_ GPI02_I000	IO	CAN1 Error signal, active low input
P118	GPI010	B18	ALT5	NANDF_D5_ GPI02_I005	IO	

SMARC Edge Finger		Freescale i.MX6 CPU			Type	Description
Pin#	Pin Name	Ball	Mode	Signal Name		
P119	GPI011	A16	ALT5	NANDF_ALE__ GPIO6_I008	IO	
P120	GND				P	
P121	I2C_PM_CK	H20	ALT6	EIM_D21__ I2C1_SCL	IO OD	Power management I2C bus clock
P122	I2C_PM_DAT	G23	ALT1	EIM_D28__ I2C1_SDA	IO OD	Power management I2C bus data
P123	BOOT_SEL0#	--	--	--	I	SYSBOOT and Line De-multiplexer Logic Pulled up on Module. Driven by OD part on Carrier.
P124	BOOT_SEL1#	--	--	--	I	SYSBOOT and Line De-multiplexer Logic Pulled up on Module. Driven by OD part on Carrier.
P125	BOOT_SEL2#	--	--	--	I	SYSBOOT and Line De-multiplexer Logic Pulled up on Module. Driven by OD part on Carrier.
P126	RESET_OUT#	--	--	--	O	General purpose reset output to Carrier board.

SMARC Edge Finger		Freescale i.MX6 CPU			Type	Description
Pin#	Pin Name	Ball	Mode	Signal Name		
P127	RESET_IN#	--	--	--	I	Reset input from Carrier board. Carrier drives low to force a Module reset, floats the line otherwise Pulled up on Module. Driven by OD part on Carrier.
P128	POWER_BTN#	--	--	--	I	Power-button input from carrier board. Carrier to float the line in in-active state. Active low, level sensitive. It is de-bounced on the Module Pulled up on Module. Driven by OD part on Carrier.
P129	SER0_TX	F13	ALT1	SD3_DAT7__ UART1_TX_DATA	O	Asynchronous serial port data out
P130	SER0_RX	E13	ALT1	SD3_DAT6__ UART1_RX_DATA	I	Asynchronous serial port data in
P131	SER0_RTS#	G21	ALT4	EIM_D19__ UART1_RTS_B	O	Request to Send handshake line for SER0
P132	SER0_CTS#	G20	ALT4	EIM_D20__ UART1_CTS_B	I	Clear to Send handshake line for SER0
P133	GND				P	Ground
P134	SER1_TX	E24	ALT4	EIM_D26__ UART2_TX_DATA	O	Asynchronous serial port data out
P135	SER1_RX	E25	ALT4	EIM_D27__ UART2_RX_DATA	I	Asynchronous serial port data in

SMARC Edge Finger		Freescale i.MX6 CPU			Type	Description
Pin#	Pin Name	Ball	Mode	Signal Name		
P136	SER2_TX	M2	ALT3	CSI0_DAT12__ UART4_TX_DATA		Asynchronous serial port data out
P137	SER2_RX	L1	ALT3	CSI0_DAT13__ UART4_RX_DATA		Asynchronous serial port data in
P138	SER2_RTS#	L3	ALT3	CSI0_DAT17__ UART4_RTS_B		Request to Send handshake line for SER2
P139	SER2_CTS#	L4	ALT3	CSI0_DAT16__ UART4_CTS_B		Clear to Send handshake line for SER2
P140	SER3_TX	M4	ALT3	CSI0_DAT14__ UART5_TX_DATA	O	Asynchronous serial port data out
P141	SER3_RX	M5	ALT3	CSI0_DAT15__ UART5_RX_DATA	I	Asynchronous serial port data in
P142	GND				P	Ground
P143	CAN0_TX	R3	ALT3	GPIO_7__ FLEXCAN1_TX	O	CAN0 Transmit output
P144	CAN0_RX	R5	ALT3	GPIO_8__ FLEXCAN1_RX	I	CAN0 Receive input
P145	CAN1_TX	T6	ALT0	KEY_COL4__ FLEXCAN2_TX	O	CAN1 Transmit output
P146	CAN1_RX	V5	ALT0	KEY_ROW4__ FLEXCAN2_RX	I	CAN1 Receive input
P147	VDD_IN				P	Power in
P148	VDD_IN				P	Power in
P149	VDD_IN				P	Power in
P150	VDD_IN				P	Power in
P151	VDD_IN				P	Power in
P152	VDD_IN				P	Power in

<i>SMARC Edge Finger</i>		<i>Freescale i.MX6 CPU</i>			<i>Type</i>	<i>Description</i>
<i>Pin#</i>	<i>Pin Name</i>	<i>Ball</i>	<i>Mode</i>	<i>Signal Name</i>		
<i>P153</i>	<i>VDD_IN</i>				<i>P</i>	<i>Power in</i>
<i>P154</i>	<i>VDD_IN</i>				<i>P</i>	<i>Power in</i>
<i>P155</i>	<i>VDD_IN</i>				<i>P</i>	<i>Power in</i>
<i>P156</i>	<i>VDD_IN</i>				<i>P</i>	<i>Power in</i>

SMARC Edge Finger		Freescale i.MX6 CPU			Type	Description
Pin#	Pin Name	Ball	Mode	Signal Name		
S1	PCAM_VSYNC					Not used
S2	PCAM_HSYNC					Not used
S3	GND				P	Ground
S4	PCAM_PXL_CK0					Not used
S5	I2C_CAM_CK	--	--	--	IO OD	Port3 of TCA9546 Camera I2C bus clock
S6	CAM_MCK	A17	ALT4	NANDF_CS2__ CCM_CLK02	O	Master clock output for CSI camera support
S7	I2C_CAM_DAT	--	--	--	IO OD	Port3 of TCA9546 Camera I2C bus data
S8	CSI0_CK+ / PCAM_D10					Not used
S9	CSI0_CK- / PCAM_D11					Not used
S10	GND				P	Ground
S11	CSI0_D0+ / PCAM_D12					Not used
S12	CSI0_D0- / PCAM_D13					Not used
S13	GND				P	Ground
S14	CSI0_D1+ / PCAM_D14					Not used
S15	CSI0_D1- / PCAM_D15					Not used
S16	GND				P	Ground



SMARC Edge Finger		Freescale i.MX6 CPU			Type	Description
Pin#	Pin Name	Ball	Mode	Signal Name		
S17	AFB0_OUT					Not used
S18	AFB1_OUT					Not used
S19	AFB2_OUT					Not used
S20	AFB3_IN					Not used
S21	AFB4_IN					Not used
S22	AFB5_IN					Not used
S23	AFB6_PTIO					Not used
S24	AFB7_PTIO					Not used
S25	GND				P	Ground
S26	SDMMC_D0	E14	ALT0	SD3_DAT0__ SD3_DATA0	IO	4-bit eMMC Data 0
S27	SDMMC_D1	F14	ALT0	SD3_DAT1__ SD3_DATA1	IO	4-bit eMMC Data 1
S28	SDMMC_D2	A15	ALT0	SD3_DAT2__ SD3_DATA2	IO	4-bit eMMC Data 2
S29	SDMMC_D3	B13	ALT0	SD3_DAT3__ SD3_DATA3	IO	4-bit eMMC Data 3

SMARC Edge Finger		Freescale i.MX6 CPU			Type	Description
Pin#	Pin Name	Ball	Mode	Signal Name		
S30	SDMMC_D4					Not used
S31	SDMMC_D5					Not used
S32	SDMMC_D6					Not used
S33	SDMMC_D7					Not used
S34	GND					Ground
S35	SDMMC_CLK	D14	ALT0	SD3_CLK__ SD3_CLK	O	SDMMC Clock Signal
S36	SDMMC_CMD	B13	ALT0	SD3_CMD__ SD3_CMD	O	SDMMC Command signal
S37	SDMMC_RST#	D15	ALT0	SD3_RST__ SD3_RESET	O	Reset signal to eMMC device
S38	AUDIO_MCK	P4	ALT3	CSI0_MCLK__ CCM_CLK01	O	Master clock output to Audio codecs
S39	I2S0_LRCK	N4	ALT4	CSI0_DAT6__ AUD3_TXFS	IO	Left& Right audio synchronization clock
S40	I2S0_SDOUT	P2	ALT4	CSI0_DAT5__ AUD3_TXD	O	Digital audio Output
S41	I2S0_SDIN	N3	ALT4	CSI0_DAT7__ AUD3_RXD	I	Digital audio Input
S42	I2S0_CK	N1	ALT4	CSI0_DAT4__ AUD3_TXC	IO	Digital audio clock
S43	I2S1_LRCK					Not used
S44	I2S1_SDOUT					Not used
S45	I2S1_SDIN					Not used
S46	I2S1_CK					Not used
S47	GND				G	Ground

SMARC Edge Finger		Freescale i.MX6 CPU			Type	Description
Pin#	Pin Name	Ball	Mode	Signal Name		
S48	I2C_GP_CK	--	--	--	IO OD	Port1 of TCA9546 General purpose I2C bus clock
S49	I2C_GP_DAT	--	--	--	IO OD	Port1 of TCA9546 General purpose I2C bus clock
S50	I2S2_LRCK					Not used
S51	I2S2_SDOUT					Not used
S52	I2S2_SDIN					Not used
S53	I2S2_CK					Not used
S54	SATA_ACT#	R7	ALT5	GPIO_3__ GPIO1_I003	O OD	Serial ATA Led. Open collector output pin driven during SATA command activity.
S55	AFB8_PTIO					Not used
S56	AFB9_PTIO					Not used
S57	PCAM_ON_CSI0#					Not used
S58	PCAM_ON_CSI1#					Not used
S59	SPDIF_OUT	R1	ALT4	GPIO_17__ SPDIF_OUT	O	Digital Audio Out

SMARC Edge Finger		Freescale i.MX6 CPU			Type	Description
Pin#	Pin Name	Ball	Mode	Signal Name		
S60	SPDIF_IN	R2	ALT4	GPIO_16__ SPDIF_IN	I	Digital Audio In
S61	GND				P	Ground
S62	AFB_DIFF0+	Y2	ALT0	LVDS1_TX0_P	AIO	LVDS1 LCD data channel differential pairs 1
S63	AFB_DIFF0-	Y1	ALT0	LVDS1_TX0_N	AIO	LVDS1 LCD data channel differential pairs 1
S64	GND					
S65	AFB_DIFF1+	AA1	ALT0	LVDS1_TX1_P	AIO	LVDS1 LCD data channel differential pairs 2
S66	AFB_DIFF1-	AA2	ALT0	LVDS1_TX1_N	AIO	LVDS1 LCD data channel differential pairs 2
S67	GND				P	Ground
S68	AFB_DIFF2+	AB2	ALT0	LVDS1_TX2_P	AIO	LVDS1 LCD data channel differential pairs 3
S69	AFB_DIFF2-	AB1	ALT0	LVDS1_TX2_N	AIO	LVDS1 LCD data channel differential pairs 3
S70	GND				P	Ground
S71	AFB_DIFF3+	Y4	ALT0	LVDS1_CLK_P	AIO	LVDS1 LCD differential clock pairs
S72	AFB_DIFF3-	Y3	ALT0	LVDS1_CLK_N	AIO	LVDS1 LCD differential clock pairs
S73	GND				P	Ground

SMARC Edge Finger		Freescale i.MX6 CPU			Type	Description
Pin#	Pin Name	Ball	Mode	Signal Name		
S74	AFB_DIFF4+	AA4	ALT0	LVDS1_TX3_P	AIO	LVDS1 LCD data channel differential pairs 4
S75	AFB_DIFF4-	AA3	ALT0	LVDS1_TX3_N	AIO	LVDS1 LCD data channel differential pairs 4
S76	PCIE_B_RST#					Not used
S77	PCIE_C_RST#					Not used
S78	PCIE_C_RX+					Not used
S79	PCIE_C_RX-					Not used
S80	GND				P	Ground
S81	PCIE_C_TX+					Not used
S82	PCIE_C_TX-					Not used
S83	GND				P	Ground
S84	PCIE_B_REFCK+					Not used
S85	PCIE_B_REFCK-					Not used
S86	GND				P	Ground
S87	PCIE_B_RX+					Not used
S88	PCIE_B_RX-					Not used
S89	GND				P	Ground
S90	PCIE_B_TX+					Not used
S91	PCIE_B_TX-					Not used
S92	GND				P	Ground

SMARC Edge Finger		Freescale i.MX6 CPU			Type	Description
Pin#	Pin Name	Ball	Mode	Signal Name		
S93	LCD_D0	P24	ALT0	DISP0_DAT0__ IPU1_DISP0_DATA00	O	8 bit BLU color data - 18 bit display implementations leave the two LS bits (D0, D1) not connected
S94	LCD_D1	P22	ALT0	DISP0_DAT1__ IPU1_DISP0_DATA01	O	
S95	LCD_D2	V23	ALT0	DISP0_DAT2__ IPU1_DISP0_DATA02	O	
S96	LCD_D3	P21	ALT0	DISP0_DAT3__ IPU1_DISP0_DATA03	O	
S97	LCD_D4	P20	ALT0	DISP0_DAT4__ IPU1_DISP0_DATA04	O	
S98	LCD_D5	R25	ALT0	DISP0_DAT5__ IPU1_DISP0_DATA05	O	
S99	LCD_D6	R23	ALT0	DISP0_DAT6__ IPU1_DISP0_DATA06	O	
S100	LCD_D7	R24	ALT0	DISP0_DAT7__ IPU1_DISP0_DATA07	O	
S101	GND				P	Ground

SMARC Edge Finger		Freescale i.MX6 CPU			Type	Description
Pin#	Pin Name	Ball	Mode	Signal Name		
S102	LCD_D8	R22	ALT0	DISP0_DAT8__ IPU1_DISP0_DATA08	O	8 bit GRN color data - 18 bit display implementations leave the two LS bits (D8, D9) not connected
S103	LCD_D9	T25	ALT0	DISP0_DAT9__ IPU1_DISP0_DATA09	O	
S104	LCD_D10	R21	ALT0	DISP0_DAT10__ IPU1_DISP0_DATA10	O	
S105	LCD_D11	T23	ALT0	DISP0_DAT11__ IPU1_DISP0_DATA11	O	
S106	LCD_D12	T24	ALT0	DISP0_DAT12__ IPU1_DISP0_DATA12	O	
S107	LCD_D13	R20	ALT0	DISP0_DAT13__ IPU1_DISP0_DATA13	O	
S108	LCD_D14	U25	ALT0	DISP0_DAT14__ IPU1_DISP0_DATA14	O	
S109	LCD_D15	T22	ALT0	DISP0_DAT15__ IPU1_DISP0_DATA15	O	
S110	GND				P	Ground

SMARC Edge Finger		Freescale i.MX6 CPU			Type	Description
Pin#	Pin Name	Ball	Mode	Signal Name		
S111	LCD_D16	T21	ALT0	DISP0_DAT16__ IPU1_DISP0_DATA16	O	8 bit RED color data - 18 bit display implementations leave the two LS bits (D16, D17) not connected
S112	LCD_D17	U24	ALT0	DISP0_DAT17__ IPU1_DISP0_DATA17	O	
S113	LCD_D18	V25	ALT0	DISP0_DAT18__ IPU1_DISP0_DATA18	O	
S114	LCD_D19	U23	ALT0	DISP0_DAT19__ IPU1_DISP0_DATA19	O	
S115	LCD_D20	U22	ALT0	DISP0_DAT20__ IPU1_DISP0_DATA20	O	
S116	LCD_D21	T20	ALT0	DISP0_DAT21__ IPU1_DISP0_DATA21	O	
S117	LCD_D22	V24	ALT0	DISP0_DAT22__ IPU1_DISP0_DATA22	O	
S118	LCD_D23	W24	ALT0	DISP0_DAT23__ IPU1_DISP0_DATA23	O	
S119	GND				P	Ground
S120	LCD_DE	N21	ALT0	DI0_PIN15__ IPU1_DI0_PIN15	O	Display Enable-signal is high during the active display line; low otherwise
S121	LCD_VS	N20	ALT0	DI0_PIN3__ IPU1_DI0_PIN03	O	Vertical Sync-high pulse indicates the start of a new display frame
S122	LCD_HS	N25	ALT0	DI0_PIN2__ IPU1_DI0_PIN02	O	Horizontal Sync - high pulse indicates the start of a new horizontal display line



SMARC Edge Finger		Freescale i.MX6 CPU			Type	Description
Pin#	Pin Name	Ball	Mode	Signal Name		
S123	LCD_PCK	N19	ALT0	DI0_DISP_CLK_ IPU1_DI0_DISP_CLK	O	Pixel clock - display data transitions on the positive clock edge
S124	GND				P	Ground
S125	LVDS0+	U1	ALT0	LVDS0_TX0_P	AIO	LVDS0 LCD data channel differential pairs 1
S126	LVDS0-	U2	ALT0	LVDS0_TX0_N	AIO	LVDS0 LCD data channel differential pairs 1
S127	LCD_BKLT_EN	T5	ALT5	GPIO_0_ GPIO1_I000	O	High enables panel backlight
S128	LVDS1+	U3	ALT0	LVDS0_TX1_P	AIO	LVDS0 LCD data channel differential pairs 2
S129	LVDS1-	U4	ALT0	LVDS0_TX1_N	AIO	LVDS0 LCD data channel differential pairs 2
S130	GND				P	Ground
S131	LVDS2+	V1	ALT0	LVDS0_TX2_P	AIO	LVDS0 LCD data channel differential pairs 3
S132	LVDS2-	V2	ALT0	LVDS0_TX2_N	AIO	LVDS0 LCD data channel differential pairs 3
S133	LCD_VDD_EN	T1	ALT5	GPIO_2_ GPIO1_I002	O	High enables panel VDD
S134	LVDS_CK+	V3	ALT0	LVDS0_CLK_P		LVDS0 LCD differential clock pairs

SMARC Edge Finger		Freescale i.MX6 CPU			Type	Description
Pin#	Pin Name	Ball	Mode	Signal Name		
S135	LVDS_CK-	V4	ALT0	LVDS0_CLK_N		LVDS0 LCD differential clock pairs
S136	GND				P	Ground
S137	LVDS3+	W1	ALT0	LVDS0_TX3_P	AIO	LVDS0 LCD data channel differential pairs 4
S138	LVDS3-	W2	ALT0	LVDS0_TX3_N	AIO	LVDS0 LCD data channel differential pairs 4
S139	I2C_LCD_CK	--	--	--	IO OD	Port2 of TCA9546  LCD display I2C bus clock
S140	I2C_LCD_DAT	--	--	--	IO OD	Port2 of TCA9546  LCD display I2C bus clock
S141	LCD_BKLT_PWM	T4	ALT5	GPIO_1__  PWM2_OUT	O	Display backlight PWM control
S142	LCD_DUAL_PCK					Not used
S143	GND				P	Ground
S144	RSVD / EDP_HPD					Not used
S145	WDT_TIME_OUT#	T2	ALT1	GPIO_9__ WDOG1_B	O	Watchdog-Timer Output
S146	PCIE_WAKE#	E19	ALT5	SD1_DAT2__ GPIO1_I019	I	PCI Express Wake Event: Sideband wake signal asserted by components requesting wakeup.

SMARC Edge Finger		Freescale i.MX6 CPU			Type	Description
Pin#	Pin Name	Ball	Mode	Signal Name		
S147	VDD_RTC				P	Low current RTC circuit backup power - 3.0V nominal It is sourced from a Carrier based Lithium cell or Super Cap
S148	LID#	J24	ALT5	EIM_OE__ GPIO2_IO25	I	Lid open/close indication to Module. Low indicates lid closure (which system may use to initiate a sleep state). Carrier to float the line in in-active state. Active low, level sensitive. Should be de-bounced on the Module Pulled up on Module. Driven by OD part on Carrier.
S149	SLEEP#	H24	ALT5	EIM_CS0__ GPIO2_IO23	I	Sleep indicator from Carrier board. May be sourced from user Sleep button or Carrier logic. Carrier to float the line in in-active state. Active low, level sensitive. Should be de-bounced on the Module. Pulled up on Module. Driven by OD part on Carrier.

SMARC Edge Finger		Freescale i.MX6 CPU			Type	Description
Pin#	Pin Name	Ball	Mode	Signal Name		
S150	VIN_PWR_BAD#				I	Power bad indication from Carrier board. Module and Carrier power supplies (other than Module and Carrier power supervisory circuits) shall not be enabled while this signal is held low by the Carrier. Pulled up on Module. Driven by OD part on Carrier.
S151	CHARGING#	J23	ALT5	EIM_CS1__ GPIO2_IO24	I	Held low by Carrier if DC input for battery charger is present. Pulled up on Module. Driven by OD part on Carrier.
S152	CHARGER_PRSENT#				I	
S153	CARRIER_STBY#	P6	ALT3	GPIO_18__ GPIO7_IO13	O	The Module shall drive this signal low when the system is in a standby power state

SMARC Edge Finger		Freescale i.MX6 CPU			Type	Description
Pin#	Pin Name	Ball	Mode	Signal Name		
S154	CARRIER_PWR_ON				O	Carrier board circuits (apart from power management and power path circuits) should not be powered up until the Module asserts the CARRIER_PWR_ON signal.
S155	FORCE_RECOV#	D25	ALT5	EIM_D23__ GPIO3_IO23	I	Pulled up on Module. Driven by OD part on Carrier.
S156	BATLOW#	J19	ALT5	EIM_D29__ GPIO3_IO29	I	Battery low indication to Module. Carrier to float the line in in-active state. Pulled up on Module. Driven by OD part on Carrier.
S157	TEST#				I	Held low by Carrier to invoke Module SD Boot UP. Pulled up on Module. Driven by OD part on Carrier.
S158	VDD_IO_SEL#				IO	If the Carrier supports only 1.8V I/O, then the Carrier shall tie the VDD_IO_SEL# pin directly to GND. Otherwise floating this pin.

# Chapter 4

## Power Control Signals between SMARC Module and Carrier

This Chapter points out the handshaking rule between *SMARC* module and carrier.

Section include :

- *SMARC-FiMX6* Module Power
- Power Signals
- Power Flow and Control Signals Block Diagram
- Power States
- Power Sequences
- Terminations
- Boot Select

## **Chapter 4 Power Control Signals between SMARC-FiMX6 Module and Carrier**

SMARC modules are designed to be driven with a single +3V to +5.25V input power rail. A +5V is recommended for non-battery operated systems. Unlike Q7 module, there is no separate voltage rail for standby power, other than the very low current RTC voltage rail. All module operating and standby power comes from the single set of *VDD\_IN* pins. This suits battery power sources well, and is also easy to use with non-battery sources.

SMARC module has specific handshaking rules to the carrier by SMARC hardware specification. To design the carrier board, users need to follow these rules or it might not boot up. Some pull-up and pull-down also need to be cared to make all functions work.

### **4.1 SMARC-FiMX6 Module Power**

#### **4.1.1. Input Voltage / Main Power Rail**

The allowable Module DC input voltage range for *SMARC-FiMX6* is from 3.0V to 5.25V. This voltage is brought in on the *VDD\_IN* pins and returned through the numerous *GND* pins on the connector. A single 5V DC input is recommended if device is not operated by battery.

Ten pins are allocated to *VDD\_IN*. The connector pin current rating is 0.5A per pin. This works out to 5A total for the 10 pins. At the lowest allowed Module input voltage, this would allow up to 16.75W of electrical power to be brought in (with no de-rating on the connector current capability). With a 40% connector current de-rating, up to 10W may be brought in at 3V.

*SMARC-FiMX6* typically consumes 1.5~4W depending on solo or quad cores and is pretty safe in using the connector.

#### **4.1.2. No Separate Standby Voltage**

There is no separate voltage rail for standby power, other than the very low

current RTC voltage rail. *SMARC-FiMX6* operating and standby power comes from the single set of *VDD\_IN* pins. This suits battery power sources well, and is also easy to use with non-battery sources.

#### **4.1.3. RTC/Backup Voltage**

RTC backup power is brought in on the *VDD\_RTC* rail. The RTC consumption is typically 15 microA or less. The allowable *VDD\_RTC* voltage range shall be 2.0V to 3.25V. The *VDD\_RTC* rail is sourced from a Carrier based Lithium cell, or it may be left open if the RTC backup functions are not required. *SMARC-FiMX6* module is able to boot without a *VDD\_RTC* voltage source.

Lithium cells, if used on Carrier, shall be protected against charging by a Carrier Schottky diode. The diode is placed in series with the positive battery terminal. The diode anode is on the battery side, and the cathode on the Module *VDD\_RTC* side.

Note that if a Super cap is used, current may flow out of the Module *VDD\_RTC* rail to charge the Super Cap.

#### **4.1.4. Power Sequencing**

The Module signal *CARRIER\_PWR\_ON* exists to ensure that the Module is powered before the main body of Carrier circuits (those outside the power and power control path on the Carrier). The main body of Carrier board circuits should not be powered until the Module asserts the *CARRIER\_PWR\_ON* signal as a high. Module hardware will assert *CARRIER\_PWR\_ON* when all Module supplies necessary for Module booting are up.

The IO power of carrier board will be turn on at the stage of power on sequence. If the IO power of carrier board been turn on earlier than the *SMARC* module, the power on carrier board might feedback to *SMARC* module through IO lines and disturbs the *SMARC* module power on sequence. More seriously, it might cause to the CPU won't boot up. It is always recommended that the power on module has to be earlier than that on carrier board.

The boot up of module depends on when you release the reset signal of your carrier board. The module will boot up when the reset signal on your carrier board is released. Before that, the module will not boot up. That's



why designer needs to put the *RESET\_IN#* in the last stage of power to serve as the "power good" signal of the carrier board.

The module will not boot up till the module power is ready because the carrier board hasn't released the reset signal yet.

The sequence is as follows:

Module Power Ready --> *CARRIER\_POWER\_ON* -->*RESET\_IN#* -->Boot Up

#### **4.1.5. RESET\_IN#**

The *SMARC* module does not know the IO power status from the carrier board, and put *RESET\_IN#* in the last stage of power can serve as the "power good" signal of carrier board. This also assures that the power of carrier board is good when *SMARC* module booting up.

#### **4.1.6. VDD\_IO**

*SMARC* 1.0 specification defines the I/O voltage to be 1.8V or 3.3V or both. The 3.3V *VDD\_IO* is depreciated from *SMARC* 1.1 specification. However, many users still preferred 3.3V *VDD\_IO* because it is easier for carrier design.

*SMARC-FiMX6* supports 1.8V or 3.3V *VDD\_IO*. If the Carrier supports only 1.8V I/O, then the Carrier will tie the *VDD\_IO\_SEL#* pin directly to GND. If the Carrier supports only 3.3V *VDD\_IO*, Carriers will float the signal for 3.3V. 3.3V *SMARC-FiMX6* will not power up if module senses a 1.8V *VDD\_IO* Carrier on the *VDD\_IO\_SEL#* (due to the Carrier pulling the line down) to protect the module. It will cut the module power down if *VDD\_IO\_SEL#* is connected to GND (this is the case of 1.8V *SMARC* module).

#### **4.1.7. Power Bad Indication (VIN\_PWR\_BAD#)**

Power bad indication is from carrier board and is an input signal for Module. Module and Carrier power supplies (other than Module and Carrier power supervisory circuits) will not be enabled while this signal is held low by the Carrier.

This signal has a 100K pull-up on module and is driven by OD part on Carrier.

#### **4.1.8. System Power Domains**

It is useful to describe an *SMARC* system as being divided into a hierarchy of three power domains:

- 1) Battery Charger power domain (can be neglected if the system is not battery powered only)
- 2) *SMARC* Module power domain
- 3) Carrier Circuits power domain

The Battery Charger domain includes circuits that are active whenever either charger input power and / or battery power are available. These circuits may include power supply supervisor(s), battery chargers, fuel gauges and, depending on the battery configuration, switching power section(s) to step down a high incoming battery voltage.

The *SMARC* Module domain includes the *SMARC* module.

The Carrier Circuits domain includes “everything else” (and does not include items from the Battery Charger and Module domain, even though they may be mounted on the Carrier).

This is illustrated in the figure below.

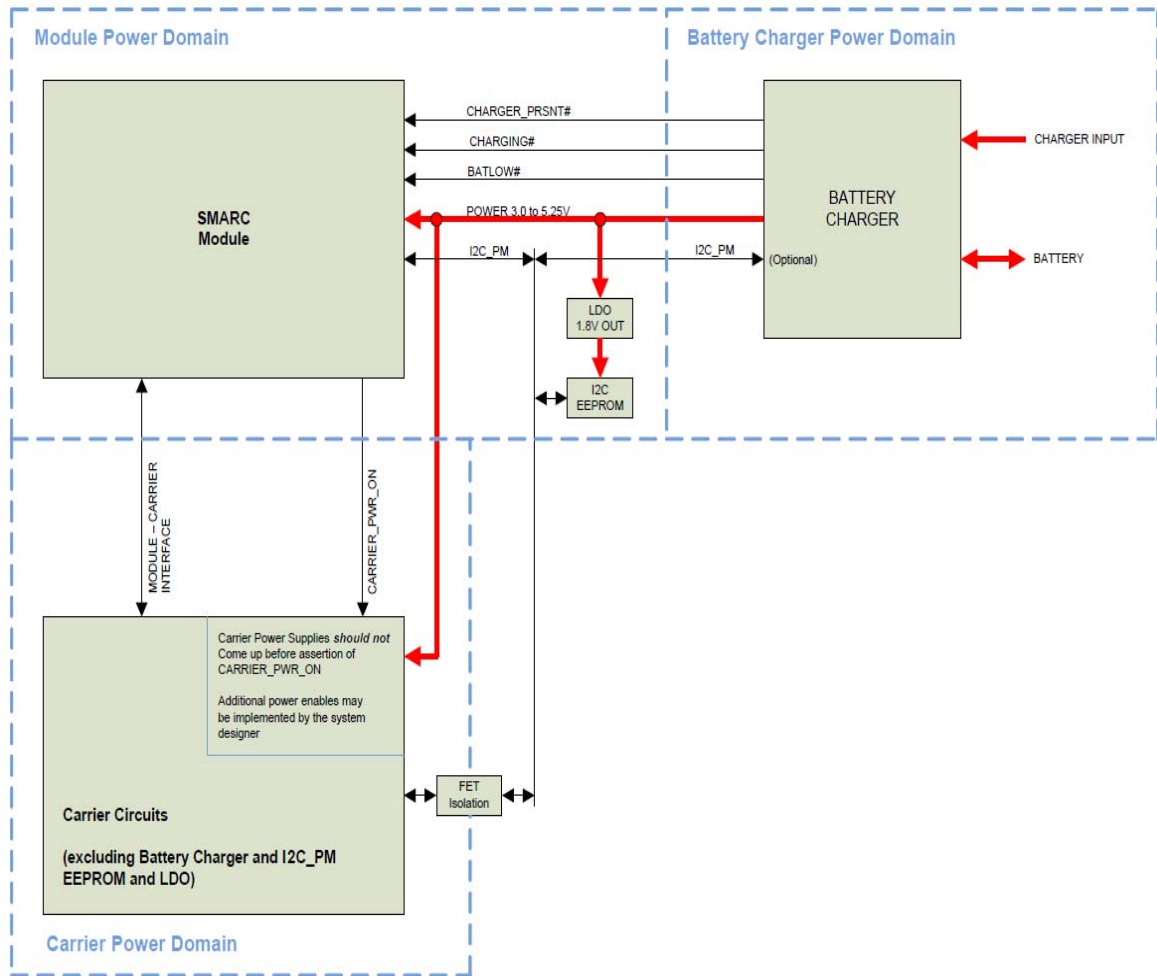

Figure 27 System Power Domains

## 4.2 Power Signals

### 4.2.1. Power Supply Signals

SMARC Edge Finger	I/O	Type	Power Rail	Description
Pin#	Pin Name			
P147, P148, P149, P150, P151, P152, P153, P154, P155, P156	VDD_IN	I	PWR 3.0V~5.25V <sup>1</sup>	Main power supply input for the module
P2, S3, P9, S10, P12, S13, P15, S16, P18, S25, P32, S34, P38, S47, P47, P50, P53, P59, S61, S64, S67, P68, S70, S73, P79, S80, P82, S83, P85, S86, P88, S89, P91, S92, P94, P97, P100, S101, P103, S110, S119, P120, S124, S130, P133, S136, P142, S143	GND	I	PWR	Common signal and power ground
S147	VDD_RTC	I	PWR 3.3V	RTC supply, can be left unconnected if internal RTC is not used

**Note:** 5V is recommended for non-battery operated system.

### 4.2.2. Power Control Signals

The input pins listed in the following table are all active low and are meant to be driven by OD (open drain) devices on the Carrier. The Carrier either floats the line or drives it to *GND*. No Carrier pull-ups are needed. The pull-up functions are performed on the Module. The voltage rail that these lines are pulled to on the Module varies, depending on the design, and may be 3.3V or *VDD\_IN*.

SMARC Edge Finger		I/O	Type	Power Rail	Description
Pin#	Pin Name				
S150	VIN_PWR_BAD#	I	CMOS	VDD_IN	Power bad indication from Carrier board
S154	CARRIER_PWR_ON	O	CMOS	VDD_IO	Signal to inform Carrier board circuits being powered up
P126	RESET_OUT#	O	CMOS	VDD_IO	General purpose reset output to Carrier board.
P127	RESET_IN#	I	CMOS	VDD_IO	Reset input from Carrier board. Carrier drives low to force a Module reset, floats the line otherwise.  Pulled up on Module.  Driven by OD part on Carrier.
S158	VDD_IO_SEL#	IO	Strap	VDD_IN	A low logic level on this signal indicates that the Module VDD_IO level is configured for the default level of 1.8V; a high value indicates that the Module is configured for 3.3V VDD_IO.  Pullup to VDD_IN rail through a resistance of 100K on module
P128	POWER_BTN#	I	CMOS	VDD_IO	Power-button input from Carrier board. Carrier to float the line in in-active state. Active low, level sensitive. It is de-bounced on the Module  Pulled up on Module.  Driven by OD part on Carrier.

### 4.2.3. Power Management Signals

The pins listed in the following table are related to power management. They will be used in a battery-operated system.

SMARC Edge Finger		I/O	Type	Power Rail	Description
Pin#	Pin Name				
S156	BATLOW#	I	CMOS	VDD_IO	Battery low indication to Module. Carrier to float the line in in-active state.  Pulled up on Module.  Driven by OD part on Carrier.
S154	CARRIER_PWR_ON	O	CMOS	VDD_IO	Signal to inform Carrier board circuits being powered up
S153	CARRIER_STBY#	O	CMOS	VDD_IO	Module will drive this signal low when the system is in a standby power state
S152	CHARGER_PRSENT#	I	CMOS	VDD_IO	Held low by Carrier if DC input for battery charger is present.  Pulled up on Module.  Driven by OD part on Carrier.
S151	CHARGING#	I	Strap	VDD_IO	Held low by Carrier during battery charging. Carrier to float the line when charge is complete.  Pulled up on Module.  Driven by OD part on Carrier.

SMARC Edge Finger		I/O	Type	Power Rail	Description
Pin#	Pin Name				
S149	SLEEP#	I	CMOS	VDD_IO	<p>Sleep indicator from Carrier board. May be sourced from user Sleep button or Carrier logic. Carrier to float the line in in-active state.</p> <p>Active low, level sensitive. Should be de-bounced on the Module.</p> <p>Pulled up on Module.</p> <p>Driven by OD part on Carrier.</p>
S148	LID#	I	CMOS	VDD_IO	<p>Lid open/close indication to Module. Low indicates lid closure (which system may use to initiate a sleep state). Carrier to float the line in in-active state. Active low, level sensitive. Should be de-bounced on the Module</p> <p>Pulled up on Module.</p> <p>Driven by OD part on Carrier.</p>

#### 4.2.4. Special Control Signals (TEST#)

SMARC-FiMX6 module boots up from an onboard NOR Flash first. The firmware (u-boot) in boot rom will read the *BOOT\_SEL* configuration and decides where to load the kernel.

In some situations like the firmware in NOR flash needed to be upgrade or at factory default where the boot rom in NOR flash is empty or at development stage that the firmware in NOR needs to be modified, users will need an alternative way to boot up from SD card first. The *TEST#* pin serves as this purpose. The *TEST#* pin is pulled high on module. If carrier board leaves this pin floating or pulls high, the module will boot from *SPI NOR*. If carrier board pulls this pin to *GND*, the module will boot up from SD card. The first stage bootloader in *i.MX6* CPU ROM codes will load the 2<sup>nd</sup> stage bootloader based on the setting of this *#TEST* pin (S157).

### 4.3 Power Flow and Control Signals Block Diagram

Following figures shows the power flow and control signals block diagram.

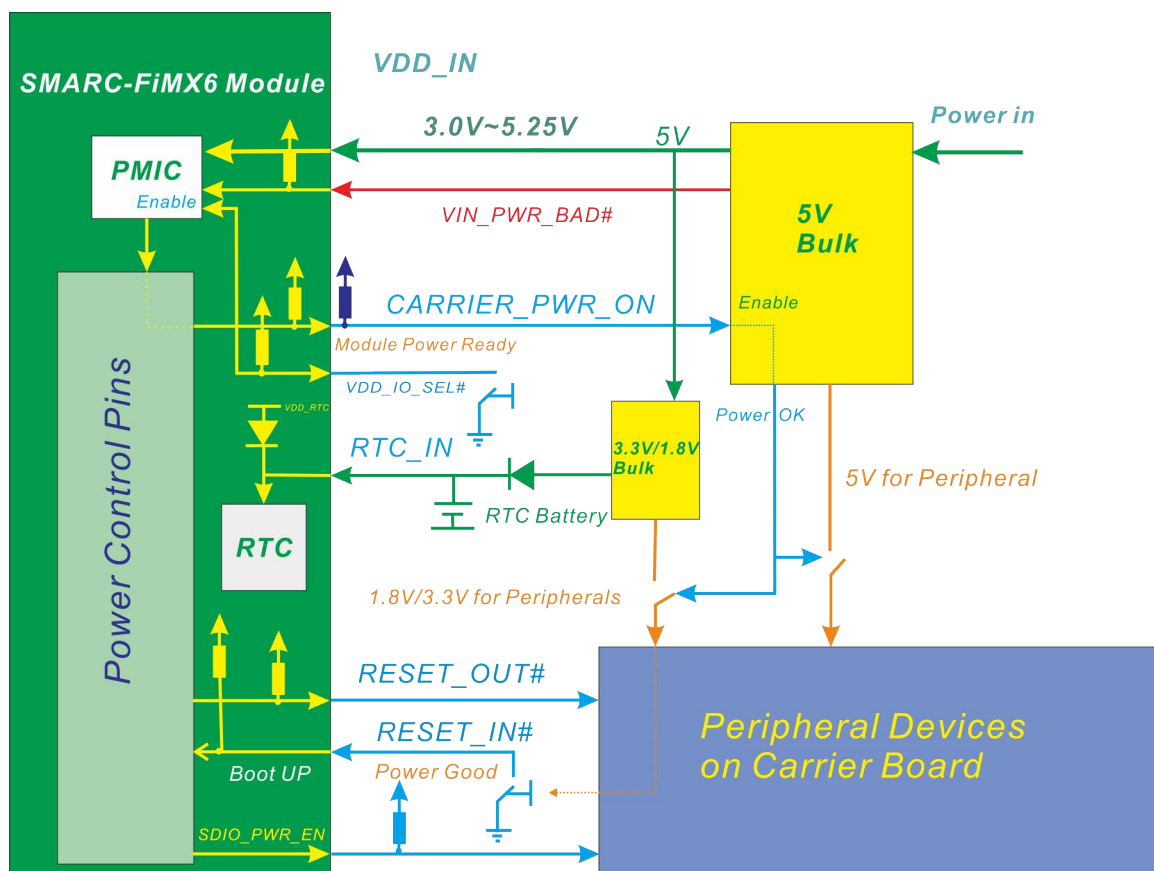

Figure 28: Power Block Diagram



## *Embedian, Inc.*

When main power is supplied from the carrier, a voltage detector will assert *VIN\_PWR\_BAD#* signal to tell the module and carrier that the power is good. *VDD\_IO\_SEL#* will be floating on carrier that represents a 3.3V *VDD\_IO* carrier or connecting to GND on carrier for 1.8V *VDD\_IO*. These two signals will turn on the PMIC on module to power on the module. If *SMARC-FiMX6* supports 3.3V I/O only, the carrier needs to float *VDD\_IO\_SEL#* pin. The module will not power up if the module senses a low level on the *VDD\_IO\_SEL#* (due to the carrier pulling the line down) and the Module supports only 3.3V I/O or receives a low-active *VIN\_PWR\_BAD#* signal.

Carrier power circuits in the carrier Power domain should not power up unless the module asserts *CARRIER\_PWR\_ON*. The module signal *CARRIER\_PWR\_ON* exists to ensure that the module is powered before the main body of carrier circuits (those outside the power and power control path on the carrier).

The main body of carrier board circuits will not be powered until the module asserts the *CARRIER\_PWR\_ON* and *VDD\_IO\_SEL#* signals being correct. Module hardware will assert *CARRIER\_PWR\_ON* and *VDD\_IO\_SEL#* when all power supplies necessary for module booting are ready. The module will continue to assert signal *RESET\_OUT#* after the release of *CARRIER\_PWR\_ON*, for a period sufficient to allow carrier power circuits to come up. When Carrier power is ready, it will assert *RESET\_IN#* to inform module booting up.

If users would like to have SD boot up, *SDIO\_PWR\_EN* signal have to be pull up to 3.3V on carrier.

Module and carrier power supplies will not be enabled if the *VIN\_PWR\_BAD#* is held low by carrier. It is a power bad indication signal from carrier and is 100k pull up to *VDD\_IN* on module.

## 4.4 Power States

The *SMARC-FiMX6* module supports different power states. The table below describes the behavior in the different states and which power rails and peripherals are active. Additional power states can be implemented if required using available GPIOs to control additional power domains and peripherals.

<b>Abbr.</b>	<b>Name</b>	<b>Description</b>	<b>Module</b>	<b>Carrier Board</b>
<i>UPG</i>	<i>Unplugged</i>	<i>No power is applied to the system, except the RTC battery might be available</i>	<i>No main VDD_IN applied from fixed DC supply, VDD_IN available if backup battery is implemented</i>	<i>No power supply input, RTC battery maybe inserted</i>
<i>OFF</i>	<i>off</i>	<i>System is off, but the carrier board input supply is available</i>	<i>The main VDD_IN is available, but the CPU and peripherals are not running. Only the PMIC is running</i>	<i>Carrier board provides power for module, the peripheral supplies are not available</i>
<i>SUS</i>	<i>Suspend</i>	<i>System is suspended and waits for wakeup sources to trigger</i>	<i>CPU is suspended, wakeup capable peripherals are running while others might be switched off</i>	<i>Power rails are available on carrier board, peripherals might be stopped by software</i>
<i>RUN</i>	<i>Running</i>	<i>System is running</i>	<i>All power rails are available, CPU and peripherals are running</i>	<i>All power rails are available, peripherals are running</i>
<i>RST</i>	<i>Reset</i>	<i>System is put in reset state by holding RESET_IN# is low</i>	<i>All power rails are available, CPU and peripherals are in reset state</i>	<i>All power rails are available, peripherals are in reset state</i>

The figure below shows a sequence diagram for the different power states. The module automatically enters into the running mode when the main power rail is applied to the module. In the running mode, the system can be set to suspend by software. There might be different wake up sources available. Consult the datasheet for *SMARC-FiMX6* module for more information about the available wakeup events.

In the running state, a shutdown request can be triggered by software. This turns off all power rails on the module and requests the carrier board to switch of the power rails for the peripherals. The module can be brought back to the

running mode in two ways. The module main voltage rail ( $VDD\_IN$ ) can be removed and applied again. If needed, this could also be done with a button and a small circuit. *SMARC-FiMX6* module supports being power cycled by asserting the  $RESET\_IN\#$  signal (e.g. by pressing the reset button or shunt and relief the reset jumper), please consult the associated module datasheet for more information about the support power cycle methods.

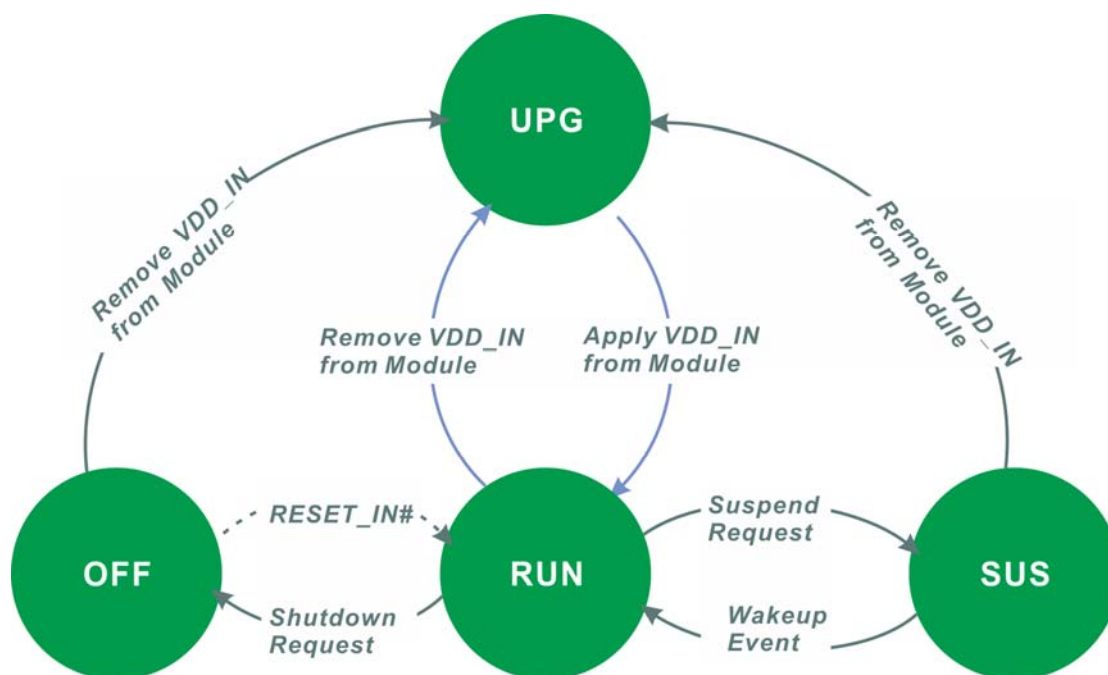

Figure 29: Power States and Transitions

#### 4.5 Power Sequences

When main power is supplied from the carrier, a voltage detector will assert  $VIN\_PWR\_BAD\#$  signal to tell the module and carrier that the power is good.  $VDD\_IO\_SEL\#$  will be floating on carrier that represents a 3.3V  $VDD\_IO$  carrier and connecting to  $GND$  on carrier that represents a 1.8V  $VDD\_IO$ . These two signals will enable the PMIC on module to power on the module. The module will not power up if the module senses an incorrect voltage level on the  $VDD\_IO\_SEL\#$  or receives a low-active  $VIN\_PWR\_BAD\#$  signal.

The *SMARC-FiMX6* module starts asserting  $CARRIER\_PWR\_ON$  and  $VDD\_IO\_SEL\#$  as soon as the main voltage supply is applied to the module and all module supplies necessary for module booting are up. This is to ensure

that the module is powered before the main body of carrier circuits (those outside the power and power control path on the carrier) and the *VDD\_IO* of module and carrier is matching. The module will continue to assert signal *RESET\_OUT#* after the release of *CARRIER\_PWR\_ON* and *VDD\_IO\_SEL#*, for a period sufficient time (at least 10ms) to allow carrier power circuits that the peripheral supplies need to ramp up.

The peripheral power rails on the carrier board need to ramp up in a correct sequence. The sequence starts normally with the highest voltage (e.g. 5V) followed by the lower voltages (e.g. 3.3V then 1.8V and so on). Peripherals normally require that a lower voltage rails is never present if a higher rail is missing. Check the datasheet of all peripheral components on the carrier board for a proper sequencing. The *SMARC-FiMX6* modules guarantees to apply the reset output *RESET\_OUT#* not earlier than 100ms after the *CARRIER\_PWR\_ON* goes high. This gives the carrier board a sufficient time for ramping up all power rails. *SDIO\_PWR\_EN* signal have to be pull up to 3.3V on carrier if users would like to have SD boot up functionality.

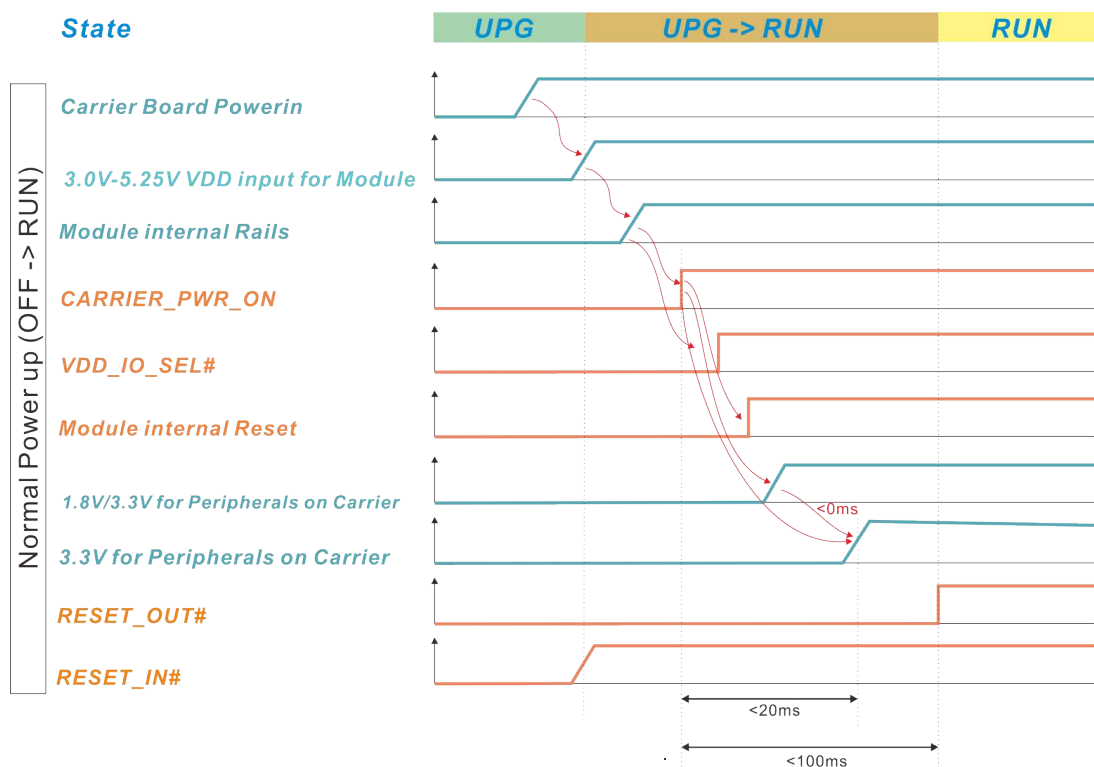

Figure 30: Power-Up Sequence

If the operating system supports it, a shutdown sequence can be initiated. Some systems may benefit from shutting down instead of just removing the main power supply as this allows the operating system to take care of any

housekeeping (e.g. bringing mass storage devices to a controlled halt). Some operating system may not provide the shutdown function.

As it is not permitted that a lower voltage rail is present when a higher voltage rail has been switched off, the sequence of shutting down the peripheral voltages needs to be considered. The lower voltages (e.g. peripheral 3.3V) need to ramp down before the higher ones do (e.g. peripheral 5V).

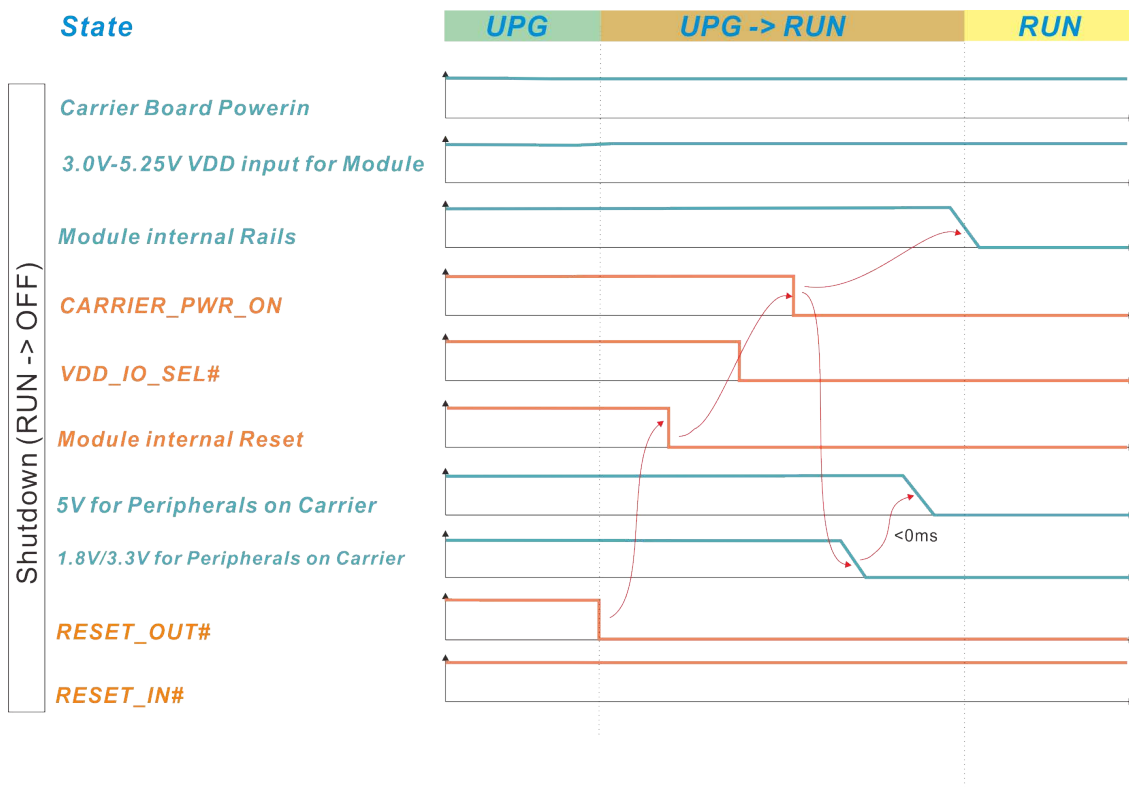

Figure 31: Shutdown Sequence

When the *RESET\_IN#* is asserted, a reset cycle is initiated. The module internal reset and the external reset output *RESET\_OUT#* are asserted as long as *RESET\_IN#* is asserted. If the reset input *RESET\_IN#* is de-asserted, the internal reset and the *RESET\_OUT#* will remain low for at least 1ms until they are also de-asserted and the module starts booting again. This guarantees a minimum reset time of 1ms even if the reset input *RESET\_IN#* is triggered for a short time.

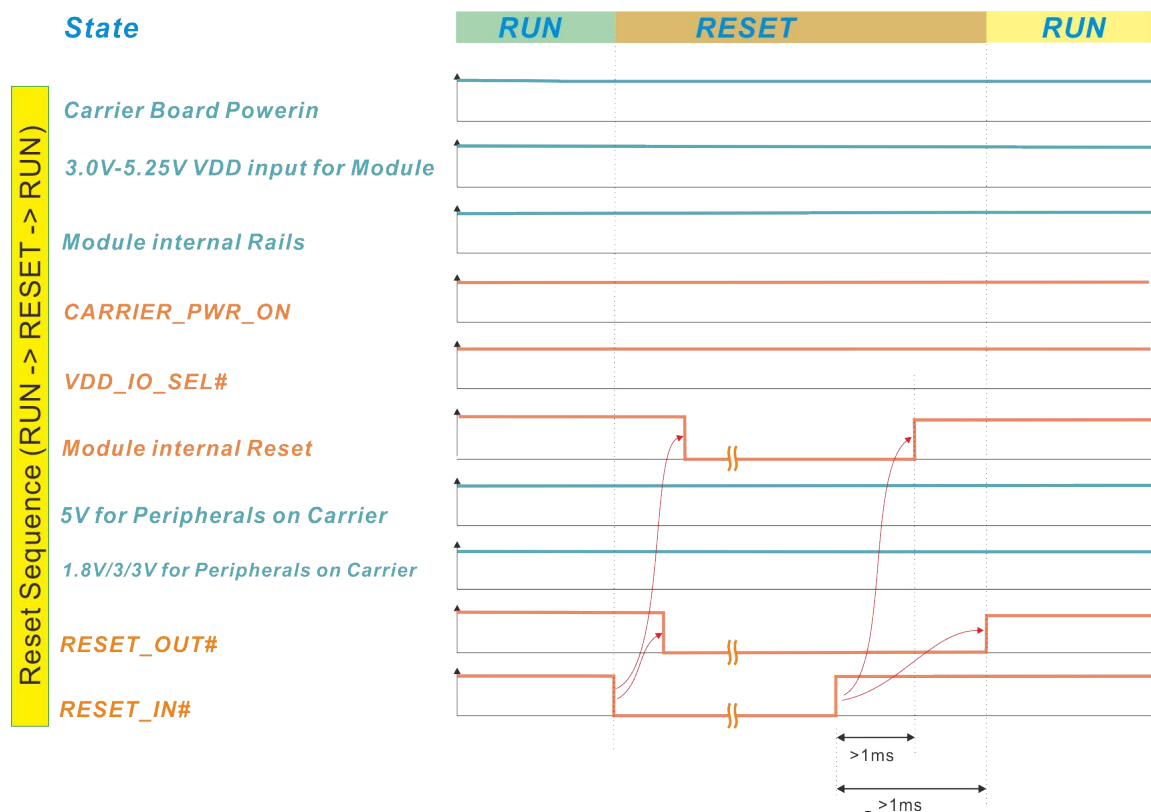

Figure 32: Reset Sequence

## 4.6 Terminations

### 4.6.1. Module Terminations

The Module signals listed below will be terminated on the Module. The terminations follow the guidance given in the table below.

<b>Signal Name</b>	<b>Series Termination</b>	<b>Parallel Termination</b>	<b>Notes</b>
<i>HDMI_CTRL_DAT</i>		<i>100k pull-up to VDD_IO</i>	
<i>HDMI_CTRL_CK</i>		<i>100k pull-up to VDD_IO</i>	
<i>HDMI_CEC</i>		<i>100k pull-up to VDD_IO</i>	
<i>I2C_PM_DAT</i>		<i>2.2K pull-up to 1.8V</i>	
<i>I2C_PM_CK</i>		<i>2.2K pull-up to 1.8V</i>	
<i>I2C_LCD_DAT</i>		<i>2.2K pull-up to VDD_IO</i>	
<i>I2C_LCD_CK</i>		<i>2.2K pull-up to VDD_IO</i>	
<i>I2C_CAM_DAT</i>		<i>2.2K pull-up to VDD_IO</i>	
<i>I2C_CAM_CK</i>		<i>2.2K pull-up to VDD_IO</i>	
<i>I2C_GP_DAT</i>		<i>2.2K pull-up to VDD_IO</i>	
<i>I2C_GP_CK</i>		<i>2.2K pull-up to VDD_IO</i>	
<i>SDIO_CD#</i>		<i>10k pull-up to 3.3V</i>	
<i>SDIO_WP</i>		<i>10k pull-up to 3.3V</i>	

<b>Signal Name</b>	<b>Series Termination</b>	<b>Parallel Termination</b>	<b>Notes</b>
<b>USBx_EN_OC#</b>		10K pull-up to 3.3V or a switched 3.3V on the Module	x is '0' or '1'  Switched 3.3V: if a USB channel is not used, then the USBx_EN_OC# pull-up rail may be held at GND to prevent leakage currents.
<b>VIN_PWR_BAD#</b>		100k pull-up to VIN	
<b>PCIE_A_TX+</b>	0.1 uF 0402 capacitor		
<b>PCIE_A_TX-</b>	0.1 uF 0402 capacitor		
<b>SATA0_TX+</b>	0.1 uF 0402 capacitor		
<b>SATA0_TX-</b>	0.1 uF 0402 capacitor		
<b>SATA0_RX+</b>	0.1 uF 0402 capacitor		
<b>SATA0_RX-</b>	0.1 uF 0402 capacitor		



#### 4.6.2. Carrier/Off-Module Terminations

The following Carrier terminations are required, if the relevant interface is used. If unused, the SMARC Module pins may be left un-connected.

<i>Module Signal</i>	<i>Carrier Series</i>	<i>Carrier Parallel</i>	<i>Notes</i>
<i>Group Name</i>	<i>Termination</i>	<i>Termination</i>	
<b>GBE_MDI</b>	<i>Magnetics module appropriate for 10/100/1000 GBE transceivers</i>	<i>Secondary side center tap terminations appropriate for Gigabit Ethernet implementations</i>	
<b>GBE_LINK</b> <i>(GBE status LED sinks)</i>		<i>If used, current limiting resistors and diodes to pulled to a positive supply rail</i>	<i>The open drain GBE status signals, GBE_LINK100#, GBE_LINK1000# and GBE_LINK_ACT#, if used, need Carrier based current limiting resistors and LEDs. The LED may be integrated into a Carrier RJ45 jack. A resistor of 68 ohms, and a LED with the anode tied to Carrier 3.3V, is typical.</i>
<b>LVDS LCD</b>		<i>100 ohm resistive termination across the differential pairs at the endpoint of the signal path, usually on the display assembly</i>	

<i>Module Signal</i>	<i>Carrier Series</i>	<i>Carrier Parallel</i>	<i>Notes</i>
<i>Group Name</i>	<i>Termination</i>	<i>Termination</i>	
<i>HDMI_CTRL_DAT</i>			<p><i>Pull-ups to VDD_IO on each of these lines is required on the Carrier.</i></p> <p><i>The pull-ups may be part of an integrated HDMI ESD protection and control-line level shift device, such as the Texas Instruments TPD12S016.</i></p> <p><i>If discrete Carrier pull-ups are used, they should be 10K.</i></p>
<i>HDMI_CTRL_CK</i>			
<i>HDMI_CEC</i>			
<i>PCIE_A_RX</i>	<i>Series coupling caps near the TX pins of the Carrier board PCIe device</i>		

## 4.7 Boot Device Selection

SMARC hardware specification defines three pins (*BOOT\_SEL[0:2]*) that allow the Carrier board user to select from eight possible boot devices. The first stage of bootloader on *SMARC-FiMX6* will boot up to SPI NOR flash first. The firmware on NOR flash will read the boot device configuration and load the second stage bootloader from selected boot devices. The *BOOT\_SELx#* pins are weakly pulled up on the Module and the pin states decoded by module logic. The Carrier shall either leave the Module pin Not Connected (“Float” in the table below) or shall pull the pin to GND, per the table below.

	Carrier Connection			Boot Source
	<i>BOOT_SEL2#</i>	<i>BOOT_SEL1#</i>	<i>BOOT_SEL0#</i>	
0	GND	GND	GND	Carrier SATA
1	GND	GND	Float	Carrier SD Card
2	GND	Float	GND	Carrier eMMC Flash
3	GND	Float	Float	Carrier SPI
4	Float	GND	GND	Module Device (TBD)
5	Float	GND	Float	Remote Boot (TBD)
6	Float	Float	GND	Module eMMC Flash
7	Float	Float	Float	Module SPI