

User's Manual

Computer on Module

*Qualcomm/NXP i.MX7 Cortex A7
24bits dual-channel LVDS LCD
4 x COM Ports
1 x SDHC
1 x USB OTG 2.0
2 x 10/100/1000M Gigabit Ethernet
2 x CAN Bus, 2 x SPIs, 4 x I2Cs
1 x PCIe, 1 x MIPI*

SMARC-FiMX7

(SMARC 2.0 Compliant)





Revision History

<i>Revision</i>	<i>Date</i>	<i>Changes from Previous Revision</i>
1.0	2017/01/6	Initial Release
2.0	2017/08/02	Change Pinmux for Rev. 00B0
2.1	2019/07/03	Fix PinMux of FLEXCAN2_RX

USER INFORMATION

About This Manual

This document provides information about products from EMBEDIAN, INC. No warranty of suitability, purpose, or fitness is implied. While every attempt has been made to ensure that the information in this document is accurate, the information contained within is supplied “as-is” and is subject to change without notice.

For the circuits, descriptions and tables indicated, EMBEDIAN assumes no responsibility as far as patents or other rights of third parties are concerned.

Copyright Notice

Copyright © 2017 EMBEDIAN, INC..

All rights reserved. No part of this manual may be reproduced, transmitted, transcribed, stored in a retrieval system, or translated into any language or computer language, in any form or by any means (electronic, mechanical, photocopying, recording, or otherwise), without the express written permission of EMBEDIAN.

Trademarks

The following lists the trademarks of components used in this board.

- ARM is a registered trademark of ARM Limited.
- Android is a registered trademark of Google
- Linux is a registered trademark of Linus Torvalds.
- WinCE is a registered trademark of Microsoft
- Qualcomm is a registered trademark of Qualcomm
- All other products and trademarks mentioned in this manual are trademarks of their respective owners.

Standards

EMBEDIAN is ISO 9001:2008 and ISO14001-certified manufacturer. SMARC is an SGET standard for ARM computer on module.

Warranty

This EMBEDIAN product is warranted against defects in material and workmanship for the warranty period from the date of shipment. During the warranty period, EMBEDIAN will at its discretion, decide to repair or replace defective products.

Within the warranty period, the repair of products is free of charge as long as warranty conditions are observed.

The warranty does not apply to defects resulting from improper or inadequate maintenance or handling by the buyer, unauthorized modification or misuse, operation outside of the product’s environmental specifications or improper installation or maintenance.

Embedian, Inc.

EMBEDIAN will not be responsible for any defects or damages to other products not supplied by EMBEDIAN that are caused by a faulty EMBEDIAN product.

Technical Support

Technicians and engineers from EMBEDIAN and/or its subsidiaries and official distributors are available for technical support. We are committed to making our product easy to use and will help you use our products in your systems.

Before contacting EMBEDIAN technical support, please consult our Web site for the latest product documentation, utilities, and drivers. If the information does not help solve the problem, contact us by e-mail or telephone.

Table of Contents

CHAPTER 1 INTRODUCTION.....	9
1.1 FEATURES AND FUNCTIONALITY.....	10
1.2 MODULE VARIANT.....	12
1.3 DIFFERENCES BETWEEN MODULE VARIANTS.....	13
1.4 BLOCK DIAGRAM.....	14
1.5 SOFTWARE SUPPORT / HARDWARE ABSTRACTION.....	15
1.6 DOCUMENT AND STANDARD REFERENCES.....	15
CHAPTER 2 SPECIFICATIONS.....	19
2.1 SMARC-FIMX7 GENERAL FUNCTIONS.....	19
2.2 SMARC-FIMX7 DEBUG.....	88
2.3 MECHANICAL SPECIFICATIONS.....	88
2.4 ELECTRICAL SPECIFICATIONS.....	103
2.5 ENVIRONMENTAL SPECIFICATIONS.....	106
CHAPTER 3 CONNECTOR PINOUT.....	108
3.1 SMARC-FIMX7 CONNECTOR PIN MAPPING.....	108
CHAPTER 4 POWER CONTROL SIGNALS BETWEEN SMARC-FIMX7 MODULE AND CARRIER.....	139
4.1 SMARC-FIMX7 MODULE POWER.....	139
4.2 POWER SIGNALS.....	143
4.3 POWER FLOW AND CONTROL SIGNALS BLOCK DIAGRAM.....	147
4.4 POWER STATES.....	149
4.5 POWER SEQUENCES.....	150
4.6 TERMINATIONS.....	154
4.7 BOOT DEVICE SELECTION.....	157

Using this Manual

This guide provides information about the Embedian *SMARC-FiMX7* for Qualcomm/NXP *i.MX7* embedded *SMARC* core module family.

Conventions used in this guide

This table describes the typographic conventions used in this guide:

<i>This Convention</i>	<i>Is used for</i>
<i>Italic type</i>	Emphasis, new terms, variables, and document titles.
monospaced type	Filenames, pathnames, and code examples.

Embedian Information

Document Updates

Please always check the product specific section on the Embedian support website at www.embedian.com/ for the most current revision of this document.

Contact Information

For more information about your Embedian products, or for customer service and technical support, contact Embedian directly.

<i>To contact Embedian by</i>	<i>Use</i>
Mail	Embedian, Inc. 4F-7. 432 Keelung Rd. Sec. 1, Taipei 11051, Taiwan
World Wide Web	http://www.embedian.com/
Telephone	+ 886 2 2722 3291

Additional Resources

Please also refer to the most recent Qualcomm/NXP *i.MX7* processor reference manual and related documentation for additional information.

Chapter 1

Introduction

This Chapter gives background information on the *SMARC-FiMX7*

Section include :

- Features and Functionality
- Module Variant
- Differences between Module Variants
- Block diagram
- Software Support / Hardware Abstraction
- Module Variant
- Document and Standard References

Chapter 1 Introduction

The *SMARC-FiMX7* is a versatile small form factor Computer-On-Module with *Qualcomm/NXP i.MX7* processor and offers scalability with single and dual core processors. The dual core *ARM® Cortex®-A7* runs a peak frequency of 1.2GHz, while the single core *ARM® Cortex®-M4* has a peak frequency of 200MHz. The single core *Cortex-A7* has a peak frequency of 800MHz, while the single core *Cortex-M4* runs at 200MHz. Both the SoCs support asymmetric or heterogeneous multi-core processing, in which the real time applications can run on the *Cortex-M4*, while the user applications are taken care by *Cortex-A7*. *SMARC-FiMX7* is also the first *SMARC 2.0* specification compliant module from Embedian.

The module connector has 314 edge fingers that mate with a low profile 314 pin 0.5mm pitch right angle connector (this connector is sometimes identified as an 321 pin connector, but 7 pins are lost to the key).

Featuring *Qualcomm/NXP's i.MX7 System-on-Chip*, Embedian's *SMARC-FiMX7* offers single- or dual-channel *LVDS LCD* interface, dual Gigabit Ethernet, *SDHC*, *USB OTG 2.0*, four *UARTs* support and many peripheral interfaces in a cost effective, low power, miniature package. Embedian's *SMARC-FiMX7* thin and robust design makes it an ideal building block for reliable system design.

The module is the ideal choice for a broad range of target markets including

- Building Automation
- Enterprise Scanners and Printers
- Smart Grid and Smart Metering
- HMI Control / Security
- IOT solutions
- Smart Home Controls
- Healthcare/Patient Monitoring
- General Control Systems
- Automotive Communication Systems
- Access Control Panels
- And more

Complete and cost-efficient Embedian evaluation kits for Yocto, Ubuntu 14.04/16.04 and Android 6.0+ allow immediate and professional embedded product development with dramatically reduced design risk and time-to-market.

1.1 Features and Functionality

The *SMARC-FiMX7* module is based on the *i.MX7* processor with solo and dual core from *Qualcomm/NXP*. This processor offers a high number of interfaces. The module has the following features:

- **SMARC 2.0** compliant in an 82mm x 50mm form factor.
- Processor: *Qualcomm/NXP i.MX7* ARM Cortex-A7 up to 1.2GHz
- Memory: Onboard 8GB eMMC Flash and 4MB SPI NOR Flash
- Onboard 512MB or 1GB DDR3 ^{Note 1}
- Networking: 2 x 10/100/1000 Mbps Ethernet ^{Note 2}
 - Display: 18 or 24 bit dual-channel LVDS
- Expansion: 1 x SDHC/SDIO, 1 x USB 2.0 Host
- USB: 1 x USB 2.0 Host, 1 x USB 2.0 OTG, 1 x PCIe ^{Note 3} Gen 2.1
- A single 4KB EEPROM is provided on I2C0 that holds the board information. This information includes board name, serial number, and revision information.
- Additional Interface:
 - ◆ 4 x UARTs
 - ◆ 2 x SPI
 - ◆ 4 x I2C
 - ◆ 1 x I2S
 - ◆ 2 x CAN Bus
 - ◆ 2 x PWM
 - ◆ 12 x GPIOs
 - ◆ WDT
- SW Support: L:inux, Yocto, Ubuntu, Android 6.0+
- Power Consumption (Typcal)
 - ◆ Solo Core (*512MB DDR3L*): 0.9 Watts
 - ◆ Dual Core (*1GB DDR3L*): 1.2 Watts
- Thermal:
 - ◆ Operating Temperature Range: -20°C ~ 85°C
 - ◆ Storage Temperature: -40° ~100°C
 - ◆ Junction Temperature SoC: -40° ~105°C
- Power Supply
- 3V to 5.25V (single 5V is recommended in non-battery operation)
- 1.8V module *VDDIO* support

Note1:

SMARC-FiMX7-S (solo core) only has 512MB DDR3 on board

SMARC-FiMX7-D (dual core) only has 1GB DDR3 memory on board (2GB DDR3 memory is available on request.)

Note2:

SMARC-FiMX7-S (solo core) only supports **one** GBE port.

SMARC-FiMX7-D (dual core) supports **two** GBE ports.

Note3:

SMARC-FiMX7-S (solo core) only supports **one** USB OTG 2.0

SMARC-FiMX7-D (dual core) supports one USB Host 2.0, one USB OTG 2.0 and one PCIe interfaces..

1.2 Module Variant

The *SMARC-FiMX7* module is available with various options based on processors in this family from *Qualcomm/NXP*.

SMARC-FiMX7-X



- 1: “S” (solo core running up to 800Mhz, 512MB *DDR3L*)
“D” (dual core running up to 1.2GHz, 1GB *DDR3L*)

1.3 Differences between Module Variants

The following table shows the differences between *SMARC-FiMX7-S* and *SMARC-FiMX7-D*. It means the same if the items are not listing in the following table.

	<i>SMARC-FiMX7-S</i>	<i>SMARC-FiMX7-D</i>
<i>CPU</i>	<i>MCIMX7S5EVM08S (800Mhz)</i>	<i>MCIMX7D5EVM10S (1.2GHz)</i>
<i>DDR3L</i>	<i>512MB</i>	<i>1GB</i>
<i>GBE w/ AVB</i>	<i>1</i>	<i>2</i>
<i>USB</i>	<i>1 x USB OTG 2.0 PHY</i>	<i>1 x USB Host 2.0 PHY, 1 x USB OTG 2.0 PHY</i>
<i>PCIe (Gen 2.1)</i>	<i>N/A</i>	<i>1</i>

1.4 Block Diagram

The following diagram illustrates the system organization of the *SMARC-FiMX7*. Arrows indicate direction of control and not necessarily signal flow.

Figure 1: SMARC-FiMX7 Block Diagram

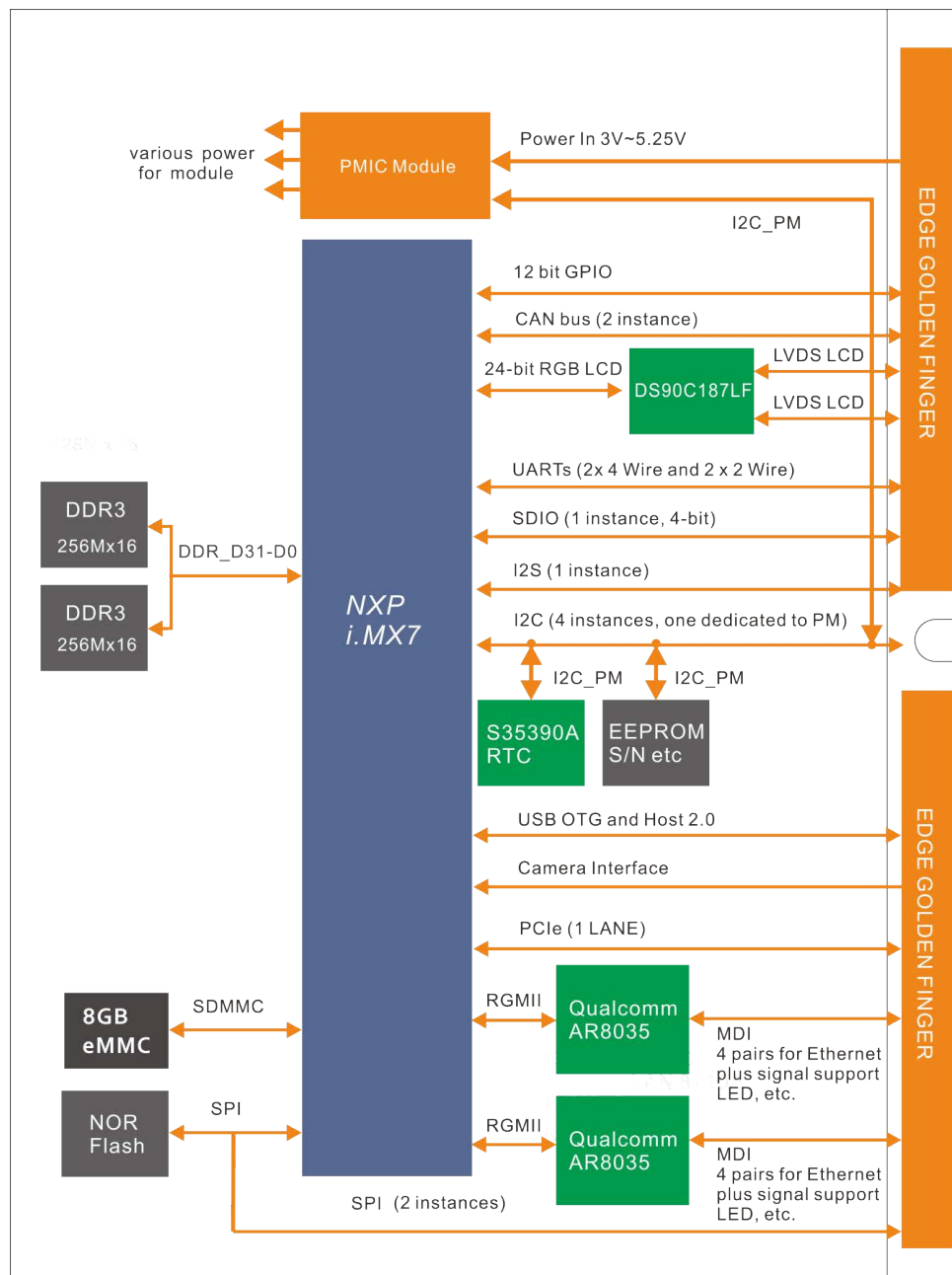

Details for this diagram will be explained in the following chapters.

1.5 Software Support / Hardware Abstraction

The Embedian *SMARC-FiMX7* Module is supported by Embedian BSPs (Board Support Package). *SMARC-FiMX7* BSP supports Linux (Ubuntu 14.04/16.04 LTS and Yocto Project) and Android 6.0+. Check with your Embedian contact for the latest BSPs.

This manual goes into a lot of detail on I/O particulars – information is provided on exactly how the various *SMARC* edge fingers tie into the Qualcomm/NXP i.MX7 SoC and to other Module hardware. This is provided for reference and context. Almost all of the I/O particulars are covered and abstracted in the BSP and it should generally not be necessary for users to deal with I/O at the register level.

1.6 Document and Standard References

1.6.1. External Industry Standard Documents

- **eMMC (Embedded Multi-Media Card)** the eMMC electrical standard is defined by JEDEC JESD84-B45 and the mechanical standard by JESD84-C44 (www.jedec.org).
- **The I2C Specification**, Version 2.1, January 2000, Philips Semiconductor (now NXP) (www.nxp.com).
- **I2S Bus Specification**, Feb. 1986 and Revised June 5, 1996, Philips Semiconductor (now NXP) (www.nxp.com).
- **JTAG (Joint Test Action Group)** defined by IEEE 1149.1-2001 - IEEE Standard Test Access Port and Boundary Scan Architecture (www.ieee.org).
- **MXM3 Graphics Module Mobile PCI Express Module Electromechanical Specification**, Version 3.0, Revision 1.1, © 2009 NVIDIA Corporation (www.mxm-sig.org).
- **PICMG® EEPROM Embedded EEPROM Specification**, Rev. 1.0, August 2010 (www.picmg.org).
- **SD Specifications Part 1 Physical Layer Simplified Specification**, Version 3.01, May 18, 2010, © 2010 SD Group and SD Card Association (Secure Digital) (www.sdcard.org).
- **SPI Bus** – “Serial Peripheral Interface” - de-facto serial interface standard defined by Motorola. A good description may be found on Wikipedia (http://en.wikipedia.org/wiki/Serial_Peripheral_Interface_Bus).
- **USB Specifications** (www.usb.org).
- **Serial ATA Revision 3.1**, July 18, 2011, Gold Revision, © Serial ATA

Embedian, Inc.

- International Organization (www.sata-io.org)
- **PCI Express Specifications** (www.pci-sig.org)
- **SPDIF (aka S/PDIF) ("Sony Philips Digital Interface)- IEC 60958-3**
-

1.6.2. SGET Documents

- **SMARC_Hardware_Specification_V1p0**, version 1.0, December 20, 2012.
- **SMARC_Hardware_Specification_V1p1**, version 1.1, May 29, 2014.
- **SMARC_Hardware_Specification_V200**, version 2.0, June 2, 2016.
- **SMARC_Design_Guide_v1p0**, version 1.0, August 26, 2013

1.6.3. Embedian Documents

The following documents are listed for reference. The Module schematic is not usually available outside of Embedian, without special permission. The other schematics will be available. Contact your Embedian representative for more information. The *SMARC* Evaluation Carrier Board Schematic is particularly useful as an example of the implementation of various interfaces on a Carrier board.

- **SMARC Evaluation Carrier Board Schematic**, PDF and OrCAD format
- **SMARC Evaluation Carrier Board User's Manual**
- **SMARC-FiMX7 User's Manual**
- **SMARC-FiMX7 Schematic Checklist**

1.6.4. Qualcomm/NXP Documents

- **IMX7DRM, i.MX7 Dual Applications Processors Reference Manual**, Aug 12, 2016 (rev. 0.1)
- **IMX7SRM, i.MX7 Solo Applications Processors Reference Manual**, Aug 12, 2016 (rev. 0.1)
- **IMX7DSHDG, Hardware Development Guide for i.MX7 Dual and Solo Applications Processors**, Jul 29, 2016 (rev. 0)
- **AN5334, i.MX7 Dual/Solo Product Lifetime Usage**, Sep. 27, 2016 (rev. 0)
- **AN5317, Loading Code on Cortex-M4 from Linux for the i.MX 6SoloX and i.MX 7Dual/7Solo Application Processors**, Aug 16, 2016 (rev. 0)

1.6.5. Qualcomm/NXP Development Tools

- ***IOMUX_TOOL for ARM® i.MX7 Microprocessors***
- ***IMX_CST_TOOL***, Qualcomm/NXP Code Signing Tool for the High Assurance Boot library.

1.6.6. Qualcomm/NXP Software Documents

- ***L4.1.15_2.0.0_LINUX_DOCS***, i.MX7 Solo/Dual Linux BSP Source Code Files. Oct. 10, 2016 (Rev.# L4.1.15_2.0.0)

1.6.7. Embedian Software Documents

- ***Embedian Linux BSP for SMARC-FiMX7 Module***
- ***Embedian Android BSP for SMARC-FiMX7 Module***
- ***Embedian Linux BSP User's Guide***
- ***Embedian Android BSP User's Guide***

1.6.8. Qualcomm/NXP Design Network

- ***SABRESD***
- ***Nucleus***
- ***QNX***

Chapter 2

Specifications

This Chapter provides SMARC-FiMX7 specifications.
Section include :

- *SMARC-FiMX7* General Functions
- *SMARC-FiMX7* Debug
- Mechanical Specifications
- Electrical Specification
- Environment Specification

Chapter 2 Specifications

2.1 SMARC-FiMX7 General Functions

2.1.1. SMARC-FiMX7 Feature Set

This section lists the complete feature set supported by the *SMARC-FiMX7* module.

SMARC Feature Specification	SMARC 2.0 Specification Maximum Number Possible	SMARC-FiMX7 Feature Support	SMARC-FiMX7 Feature Support Instances
LVDS LCD Display Support	1	Yes	1 (18 or 24 bits) ^{Note1}
DP++	1	No	N/A
HDMI Display Support	1	No	N/A
Serial Camera Support	2	Yes	1 (2 lanes)
USB Interface	6	Yes	2
PCIe Interface	4	Yes	1 (one Lane, 0 on solo core)
SATA Interface	1	No	N/A
GbE Interface	1	Yes	1
2nd GBE Interface	1	Yes	1 (0 on solo core)
SDIO Interface (4bit)	1	Yes	1 (max. 25MHz)
SPI Interface	2	Yes	2
I2S Interface	2	Yes	1
I2C Interface	5	Yes	4
Serial	4	Yes	4
CAN	2	Yes	2
VDDIO	1.8V	1.8V	1.8V

Note:

1. Single channel *LVDS* interface: 1 x 18 bpp OR 1 x 24 bpp (up to 175 MHz per interface e.g SXGA+ 1400x1050 @ 60Hz + 35% blanking)
2. Dual channel *LVDS* interface: 2 x 18 bpp OR 2 x 24 bpp (up to 185 MHz pixel clock e.g 1080p or SXGA+ 1400x1050 @ 60 Hz + 35% blanking).

2.1.2. Form Factor

The *SMARC-FiMX7* module complies with the *SMARC* General Specification module size requirements in an 82mm x 50mm form factor.

2.1.3. CPU

The *SMARC-FiMX7* implements *Qualcomm/NXP's i.MX7* ARM processor.

Qualcomm/NXP CPU	<i>i.MX7 Solo</i>	<i>i.MX7 Dual</i>
Cores	1	2
Clock	800MHz (A7) 200MHz(M4)	1.2GHz (A7) 200MHz (M4)
Memory Speed	DDR3-533	DDR3-533
Memory Bus	32-bit	64-bit
Cache	(A7) 32 KB/32 KB L1, 512 KB L2 (M4) 16 KB/16 KB L1	(A7) 32 KB/32 KB L1, 512 KB L2 (M4) 16 KB/16 KB L1
Hardware Video Acceleration	Software Only	Software Only
Hardware 2D/3D Graphics Acceleration	No, but has an ePXP	No, but has an ePXP
Parallel LCD Resolutions	1920x1080x60 (Convert to LVDS signals on module)	1920x1080x60 (Convert to LVDS signals on module)

Note:

1. The *LVDS* interface can be used either as a single channel or as a dual channel. It is also possible to use the *LVDS* interface as two independent single *LVDS* channels. To do this, it is recommended to configure the *LVDS* display in the bootloader. Three independent displays are possible when connected as two single *LVDS* channel and one *HDMI* interface.

2.1.4. Module Memory

The *SMARC-FiMX7* module supports different configurations of *DDR3L* memory. The following table shows the available options.

<i>SMARC Variants</i>	<i>i.MX7 Solo</i>	<i>i.MX7 Dual</i>
512MB DDR3L	Yes	No
1GB DDR3L	No	Yes
2GB DDR3L	No	Only on Request

Check with your Embedian contact or on the Embedian web site for updated information.

2.1.5. Onboard Storage

The *SMARC-FiMX7* module supports a 8GB *eMMC* flash memory device, 4MB *SPI NOR* flash and a 32Kb *I2C* serial *EEPROM* on the Module *I2C_GP* (*I2C2*) bus. The device used is an On Semiconductor *AT24C32* equivalent. The Module serial *EEPROM* is intended to retain Module parameter information, including a module serial number. The Module serial *EEPROM* data structure conforms to the *PICMG® EEEP Embedded EEPROM Specification*.) The onboard 4MB *SPI NOR* flash is used as *SPI* boot media. The module will always boot up from the onboard *SPI NOR* flash first. The firmware in *NOR* flash will read the configuration from the boot selection and boot up the devices from that selected.

2.1.6. Clocks

A 32.768 KHz clock is required for the *i.MX7 CPU RTC* (Real Time Clock) and external (S-35390A) *RTC*.

The *Qualcomm/NXP i.MX7 CPU* is provided with a 24 MHz clock using a crystal in normal oscillation mode (On-chip Oscillator).

The *Qualcomm AR8035 PHY* is provided with a 25 MHz clock using a crystal in normal oscillation mode.

2.1.7 LVDS Interface

The *SMARC-FiMX7* implements two 18 / 24 bit single channel LVDS output streams that are defined in SMARC 2.0 edge connector for the Primary displays. They can also be configured as an 18 / 24 bit dual-channel LVDS directly out of the *SMARC* Module.

The *LVDS LCD* signals found on the *SMARC-FiMX7* offers two LVDS channels, with up to 185 Mhz pixel clock. They are generated from 24-bit parallel RGB signals from the *Qualcomm/NXP® i.MX7* Cortex A7 processor passing through a TI *DS90C187LF* Low Power 1.8V Dual Pixel FPD-Link (LVDS) Serializer. Each channel consists of one clock pair and four data pairs. The LVDS signals support the flow of synchronous RGB data from the *i.MX7* CPU to external display devices through LVDS interface.

The LVDS interface also supports various resolutions but with stipulated maximum data rates. The data rates supported are as follows:

For single channel output: Up to 175 MHz per interface (e.g SXGA+ 1400x1050 @ 60Hz + 35 % blanking).

For dual channel output: Up to 185 MHz pixel clock (e.g 1920x1080 @ 60Hz + 35 % blanking)

The LVDS ports support the following configurations:

- One single channel output
- One dual channel output: single input split to two output channels

Note:

The *LVDS* interface can be used either as a single channel or as a dual channel.

The following figure shows the LVDS LCD block diagram.

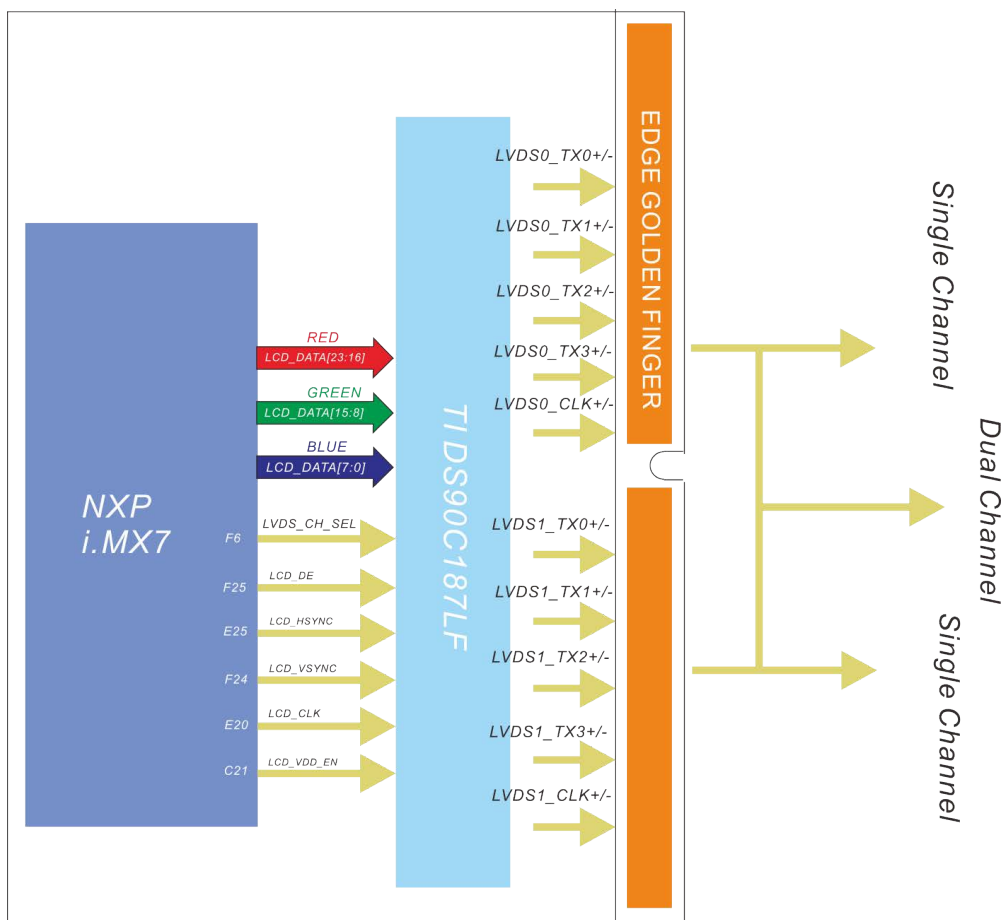

Figure 2: SMARC-FiMX7 LVDS LCD Diagram

2.1.7.1 LVDS channel select

SMARC-FiMX7 LVDS LCD interface can be configured as a single-channel LVDS output (default) or a dual-channel LVDS output by *LVDS_CH_SEL* signal. When *LVDS_CH_SEL* is set to low, it will be single-channel LVDS interface. When *LVDS_CH_SEL* is set to high, it will become a dual-channel LVDS interface.

<i>Qualcomm/NXP i.MX7 CPU</i>			<i>SMARC-FiMX7 Edge Golden Finger</i>		<i>Net Names</i>	<i>Note</i>
<i>Ball</i>	<i>Mode</i>	<i>Pin Name</i>	<i>Pin#</i>	<i>Pin Name</i>		
<i>LVDS_CH_SEL</i>						
<i>F6</i>	<i>ALT5</i>	<i>SD2_CMD__ GPIO5_I013</i>			<i>LVDS_CH _SEL</i>	<i>Set 0 as single channel. Set 1 as dual channel.</i>

2.1.7.2 LVDS Signals Data Flow

i.MX7 processor and TI DS90C187LF implementation is shown in the following table:

Qualcomm/NXP i.MX7 CPU			TI DS90C187LF		Net Names	Note
Ball	Mode	Pin Name	Pin#	Pin Name		
G23	ALT0	LCD1_DATA23__ LCD1_DATA23	B14	INA_22	LCD_DATA23	R7
D25	ALT0	LCD1_DATA22__ LCD1_DATA22	B13	INA_21	LCD_DATA22	R6
E24	ALT0	LCD1_DATA21__ LCD1_DATA21	B37	INA_5	LCD_DATA21	R5
C25	ALT0	LCD1_DATA20__ LCD1_DATA20	B36	INA_4	LCD_DATA20	R4
D24	ALT0	LCD1_DATA19__ LCD1_DATA19	B35	INA_3	LCD_DATA19	R3
E23	ALT0	LCD1_DATA18__ LCD1_DATA18	B34	INA_2	LCD_DATA18	R2
G21	ALT0	LCD1_DATA17__ LCD1_DATA17	B33	INA_1	LCD_DATA17	R1
B25	ALT0	LCD1_DATA16__ LCD1_DATA16	B32	INA_0	LCD_DATA16	R0
C24	ALT0	LCD1_DATA15__ LCD1_DATA15	B16	INA_24	LCD_DATA15	G7
D23	ALT0	LCD1_DATA14__ LCD1_DATA14	B15	INA_23	LCD_DATA14	G6
E22	ALT0	LCD1_DATA13__ LCD1_DATA13	B3	INA_11	LCD_DATA13	G5
F21	ALT0	LCD1_DATA12__ LCD1_DATA12	B2	INA_10	LCD_DATA12	G4
G20	ALT0	LCD1_DATA11__ LCD1_DATA11	B1	INA_9	LCD_DATA11	G3
B24	ALT0	LCD1_DATA10__ LCD1_DATA10	B40	INA_8	LCD_DATA10	G2
C23	ALT0	LCD1_DATA09__ LCD1_DATA09	B39	INA_7	LCD_DATAD09	G1
E21	ALT0	LCD1_DATA08__ LCD1_DATA08	B38	INA_6	LCD_DATA08	G0

Qualcomm/NXP i.MX7 CPU			TI DS90C187LF		Net Names	Note
Ball	Mode	Pin Name	Pin#	Pin Name		
F20	ALTO	LCD1_DATA07__ LCD1_DATA07	B14	INA_26	LCD_DATA07	B7
A24	ALTO	LCD1_DATA06__ LCD1_DATA06	B13	INA_25	LCD_DATA06	B6
B23	ALTO	LCD1_DATA05__ LCD1_DATA05	B37	INA_17	LCD_DATA05	B5
C22	ALTO	LCD1_DATA04__ LCD1_DATA04	B36	INA_16	LCD_DATA04	B4
A23	ALTO	LCD1_DATA03__ LCD1_DATA03	B35	INA_15	LCD_DATA03	B3
B22	ALTO	LCD1_DATA02__ LCD1_DATA02	B34	INA_14	LCD_DATA02	B2
A22	ALTO	LCD1_DATA01__ LCD1_DATA01	B33	INA_13	LCD_DATA01	B1
D21	ALTO	LCD1_DATA00__ LCD1_DATA00	B32	INA_12	LCD_DATA00	B0
E20	ALTO	LCD1_CLK__ LCD1_CLK	A6	IN_CLK	LCD_CLK	LCD Clock
F25	ALTO	LCD1_ENABLE__ LCD1_ENABLE	B12	DE	LCD_DE	Data Enable
E25	ALTO	LCD1_HSYNC__ LCD1_HSYNC	B11	VS	LCD_HSYNC	Hsync
F24	ATLO	LCD1_VSYNC__ LCD1_VSYNC	B10	HS	LCD_VSYNC	Vsync
C21	ALTO	LCD1_RESET__ LCD1_RESET	A40	PDB	LCD_VDD_EN	Power Enable

Embedian, Inc.

The path from *TI DS90C187LF* to the golden finger edge connector is show in the following table.

TI DS90C187LF		Golden Finger Edge Connector		Net Names	Note
<i>Pin</i>	<i>Pin Name</i>	<i>Pin#</i>	<i>Pin Name</i>		
DS90C187LF, Channel1 (Default)					
B31	LVDS0_0+	S125	LVDS0_0+/ eDP0_TX0+/ DSI0_D0+	LVDS0_0+	LVDS0 LCD data channel differential pairs 1
A38	LVDS0_0-	S126	LVDS0_0-/ eDP0_TX0-/ DSI0_D0-	LVDS0_0-	
B30	LVDS0_1+	S128	LVDS0_1+/ eDP0_TX1+/ DSI0_D1+	LVDS0_1+	LVDS0 LCD data channel differential pairs 2
A37	LVDS0_1-	S129	LVDS0_1-/ eDP0_TX1-/ DSI0_D1-	LVDS0_1-	
B29	LVDS0_2+	S131	LVDS0_2+/ eDP0_TX2+/ DSI0_D2+	LVDS0_2+	LVDS0 LCD data channel differential pairs 3
A36	LVDS0_2-	S132	LVDS0_2-/ eDP0_TX2-/ DSI0_D2-	LVDS0_2-	
B28	LVDS0_CK+	S134	LVDS0_CK+/ eDP0_AUX+/ DSI0_CLK+	LVDS0_CK+	LVDS0 LCD differential clock pairs
A35	LVDS0_CK-	S135	LVDS0_CK-/ eDP0_AUX-/ DSI0_CLK-	LVDS0_CK-	
B27	LVDS0_3+	S137	LVDS0_3+/ eDP0_TX3+/ DSI0_D3+	LVDS0_3+	LVDS0 LCD data channel differential pairs 4
A34	LVDS0_3-	S138	LVDS0_3-/ eDP0_TX3-/ DSI0_D3-	LVDS0_3-	

TI DS90C187LF		Golden Finger Edge Connector		Net Names	Note
Pin	Pin Name	Pin#	Pin Name		
<i>DS90C187LF, Channel2</i>					
B23	LVDS1_CK+	S108	LVDS1_CK+/ eDP1_AUX+/ DSI1_CLK+	LVDS1_CK+	LVDS1 LCD differential clock pairs
A30	LVDS1_CK-	S109	LVDS1_CK-/ eDP1_AUX-/ DSI1_CLK-	LVDS1_CK-	
B26	LVDS1_0+	S111	LVDS1_0+/ eDP1_TX0+/ DSI1_D0+	LVDS1_0+	LVDS1 LCD data channel differential pairs 1
A33	LVDS1_0-	S112	LVDS1_0-/ eDP1_TX0-/ DSI1_D0-	LVDS1_0-	
B25	LVDS1_1+	S114	LVDS1_1+/ eDP1_TX1+/ DSI1_D1+	LVDS1_1+	LVDS1 LCD data channel differential pairs 2
A32	LVDS1_1-	S115	LVDS1_1-/ eDP1_TX1-/ DSI1_D1-	LVDS1_1-	
B24	LVDS1_2+	S117	LVDS1_2+/ eDP1_TX2+/ DSI1_D2+	LVDS1_2+	LVDS1 LCD data channel differential pairs 3
A31	LVDS1_2-	S118	LVDS1_2-/ eDP1_TX2-/ DSI1_D2-	LVDS1_2-	
B21	LVDS1_3+	S120	LVDS1_3+/ eDP1_TX3+/ DSI1_D3+	LVDS1_3+	LVDS1 LCD data channel differential pairs 4
A28	LVDS1_3-	S121	LVDS1_3-/ eDP1_TX3-/ DSI1_D3-	LVDS1_3-	

A 24 bit dual channel LVDS implementation comprises 10 differential pairs: 4 pairs for odd pixel and control data; 1 pair for the LVDS clock for the odd data; 4 pairs for the even pixel data and control data, and 1 pair for the even LVDS clock. To use the dual channel LVDS mode, you need a display supporting the dual channel LVDS mode in order to receive odd and even pixel data.

2.1.7.3 Other LCD Control Signals

The signals in the table below support the *LVDS LCD* interfaces (as these are created from the same i.MX7 source).

<i>Edge Golden Finder Signal Name</i>	<i>Direction</i>	<i>Type Tolerance</i>	<i>Description</i>
<i>LCD0_VDD_EN</i>	<i>Output</i>	<i>CMOS 1.8V</i>	<i>High enables panel VDD</i>
<i>LCD0_BKLT_EN</i>	<i>Output</i>	<i>CMOS 1.8V</i>	<i>High enables panel backlight</i>
<i>LCD0_BKLT_PWM</i>	<i>Output</i>	<i>CMOS 1.8V</i>	<i>Display backlight PWM control</i>
<i>I2C_LCD_DAT</i>	<i>Bi-Dir OD</i>	<i>CMOS 1.8V</i>	<i>I2C data – to read LCD display EDID EEPROMs</i>
<i>I2C_LCD_CK</i>	<i>Output</i>	<i>CMOS 1.8V</i>	<i>I2C clock – to read LCD display EDID EEPROMs</i>

Embedian, Inc.

Below list LCD control signals that mapping to CPU iomux and SMARC edge connector.

Qualcomm/NXP i.MX7 CPU			SMARC-FiMX7 Edge Golden Finger		Net Names	Note
Ball	Mode	Pin Name	Pin#	Pin Name		
D12	ALT5	SAI1_RX_BCLK__ GPIO6_I017	S127	LCD0_BKLT_EN	LCD_ BKLT_EN	High enables panel backlight
C21	ALT5	LCD1_RESET__ GOI03_I004	S133	LCD0_VDD_EN	LCD_VDD _EN	High enables panel VDD
N3	ALT1	GPIO1_I002__ PWM2_OUT	S141	LCD0_BKLT_PWM	LCD0_ BKLT_ PWM	Display backlight PWM control
K5	ALT0	I2C3_SCL	S139	I2C_LCD_CK	I2C_ LCD_CK	I2C data – to read LCD display EDID EEPROMs
K6	ALT0	I2C3_SDA	S140	I2C_LCK_DAT	I2C_ LCD_DAT	I2C data – to read LCD display EDID EEPROMs

2.1.8 USB Interface

SMARC 2.0 specification defines 6 instances of USB interfaces. Two of them (USB 2:3) can support USB 3.0 super speed signals and two of them (USB 0:1) allow USB OTG functionality. Embedian SMARC-FiMX7 module supports two USB ports (USB 0:1). Per the SMARC 2.0 specification, the module supports a USB “On-The-Go” (OTG) 2.0 port capable of functioning either as a client or host device, on the SMARC USB0. The SMARC-FiMX67-D module also supports one additional USB2.0 host ports, on SMARC USB1. Please note that the solo core SMARC-FiMX7-S module only supports one USB OTG 2.0 on USB0 port.

The following figure shows the USB0 and USB1 block diagram.

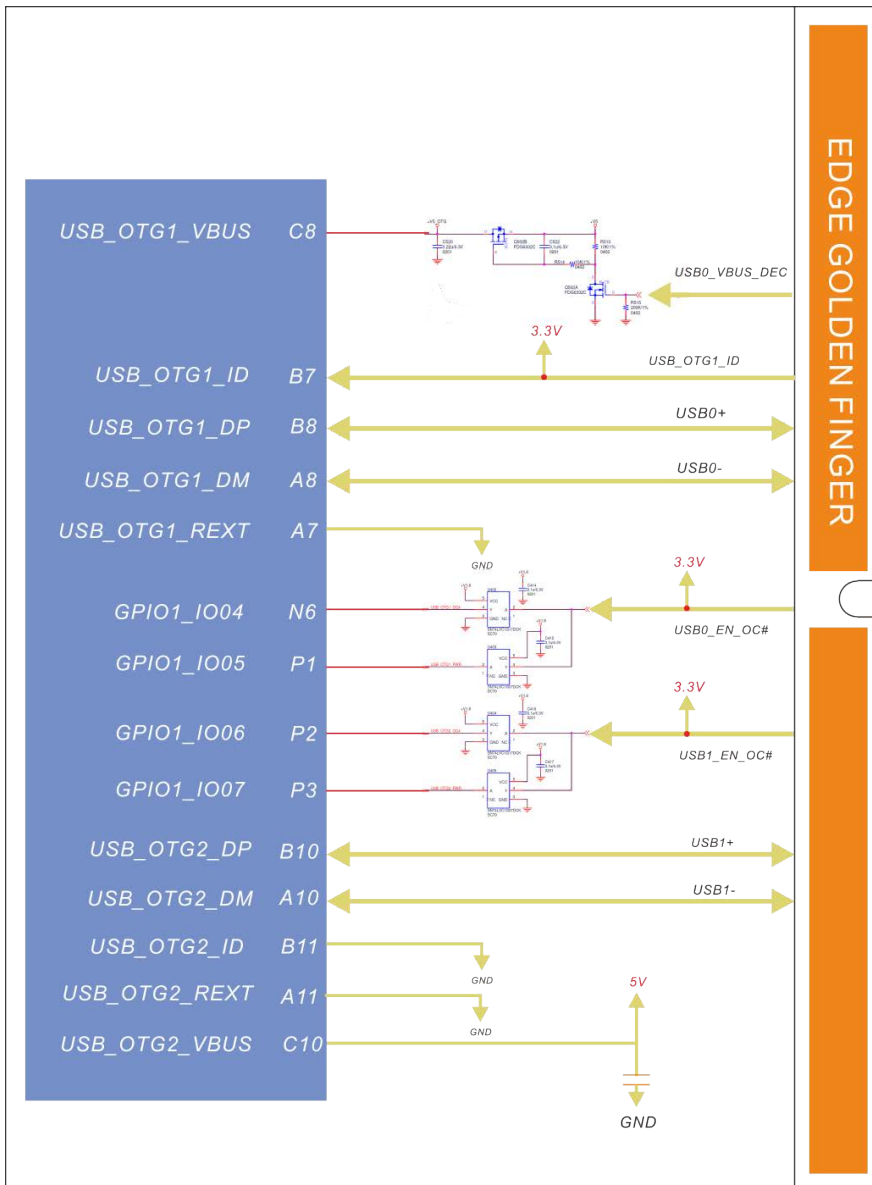

Figure 3. USB0 and USB1 Block Diagram

Embedian, Inc.

USB interface signals are exposed on the SMARC-FiMX7 edge connector as shown below:

Qualcomm/NXP i.MX7 CPU			SMARC-FiMX7 Edge Golden Finger		Net Names	Note
Ball	Mode	Pin Name	Pin#	Pin Name		
USB0 Port (OTG)						
B8		USB_OTG1_DP	P60	USB0+	USB0+	USB0 port data pair
A8		USB_OTG1_DN	P61	USB0-	USB0-	
N6	ALT1	GPI01_I004__ USB_OTG1_OC	P62	USB0_EN_OC#	USB0_EN_OC#	USB Port0 power enable/over current indication signal
P1	ALT1	GPI01_I005__ USB_OTG1_PWR				
C8		Turn on USB_OTG_VBUS	P63	USB0_VBUS_DET	USB0_VBUS_DET	USB host power detection, when this port is used as a device.
B7		USB_OTG1_ID	P64	USB0_OTG_ID	USB0_OTG_ID	USB OTG ID input, active high
USB1 Port (Host 2.0, dual core only)						
B10		USB_OTG2_DP	P65	USB1+	USB1+	USB1 port data pair
A10		USB_OTG2_DN	P66	USB1-	USB1-	
P2	ALT1	GPI01_I006__ USB_OTG2_OC	P67	USB1_EN_OC#	USB1_EN_OC#	USB Port1 power enable/over current indication signal
P3	ALT1	GPI01_I007__ USB_OTG2_PWR				

2.1.8.1 USB0 Signals

The table below shows the *USB0* related signals.

<i>Edge Golden Finder Signal Name</i>	<i>Direction</i>	<i>Type Tolerance</i>	<i>Description</i>
<i>USB0+ USB0-</i>	<i>Bi-Dir</i>	<i>USB</i>	<i>Differential USB0 Data Pair</i>
<i>USB0_EN_OC#</i>	<i>Bi-Dir OD</i>	<i>CMOS 3.3V</i>	<i>Pulled low by Module OD driver to disable USB0 power. Pulled low by Carrier OD driver to indicate over-current situation. A 10k pull-up is present on the Module to a 3.3V rail. The pull-up rail may be switched off to conserve power if the USB port is not in use. Further details may be found in Section 2.1.12.3 USBx_EN_OC# Discussion below.</i>
<i>USB0_VBUS_DET</i>	<i>Input</i>	<i>USB VBUS 5V</i>	<i>USB host power detection, when this port is used as a device.</i>
<i>USB0_OTG_ID</i>	<i>Input</i>	<i>CMOS 3.3V</i>	<i>USB OTG ID input, active high.</i>

2.1.8.2 USB1 Signals (Dual Core Only)

USB1 port is a USB 2.0 host port. The table below shows the USB1 related signals.

Edge Golden Finder Signal Name	Direction	Type Tolerance	Description
USB1+ USB1-	Bi-Dir	USB	Differential USB1 Data Pair
USB1_EN_OC#	Bi-Dir OD	CMOS 3.3V	<p>Pulled low by Module OD driver to disable USB0 power.</p> <p>Pulled low by Carrier OD driver to indicate over-current situation.</p> <p>A 10k pull-up is present on the Module to a 3.3V rail. The pull-up rail may be switched off to conserve power if the USB port is not in use. Further details may be found in Section 2.1.12.3 USBx_EN_OC# Discussion below.</p>

2.1.8.3 USBx_EN_OC# Discussion

The Module *USBx_EN_OC#* pins (where 'x' is 0 or 1 for use with *USB0* or *USB1*) are multi-function Module pins, with a 10k pull-up to a 3.3V rail on the Module, an OD driver on the Module, and, if the *OC#* (over-current) monitoring function is implemented on the Carrier, an OD driver on the Carrier. The use is as follows:

- 1) On the Carrier board, for external plug-in *USB* peripherals (*USB* memory sticks, cameras, keyboards, mice, etc.) *USB* power distribution is typically handled by *USB* power switches such as the Texas Instruments *TPS2052B* or the *Micrel MIC2026-1* or similar devices. The Carrier implementation is more straightforward if the Carrier *USB* power switches have active-high power enables and active low open drain *OC#* outputs (as the TI and *Micrel* devices referenced do). The *USB* power switch Enable and *OC#* pins for a given *USB* channel are tied together on the Carrier. The *USB* power switch enable pin must function with a low input current. The TI and *Micrel* devices referenced above require 1 microampere or less, at a 3.3V enable voltage level.
- 2) The Module drives *USBx_EN_OC#* low to disable the power delivery to the *USBx* device.
- 3) The Module floats *USBx_EN_OC#* to enable power delivery. The line is

pulled to 3.3V by the Module pull-up, enabling the Carrier board USB power switch.

- 4) If there is a USB over-current condition, the Carrier board USB power switch drives the *USBx_EN_OC#* line low. This removes the over-current condition (by disabling the USB switch enable input), and allows Module software to detect the over-current condition.
- 5) The Module software should look for a falling edge interrupt on *USBx_EN_OC#*, while the port is enabled, to detect the *OC#* condition. The *OC#* condition will not last long, as the USB power switch is disabled when the switch IC detects the *OC#* condition.
- 6) If the *USB* power to the port is disabled (*USBx_EN_OC#* is driven low by the Module) then the Module software is aware that the port is disabled, and the low input value on the port does not indicate an over-current condition (because the port power is disabled).

Carrier Board *USB* peripherals that are not removable often do not make use of *USB* power switches with current limiting and over-current detection. It is usually deemed un-necessary for non-removable devices. In these cases, the *USBx_EN_OC#* pins may be left unused, or they may be used as *USBx* power enables, without making use of the over-current detect Module input feature.

Embedian, Inc.

The *SMARC-FiMX7* Module *USB* power enable and over current indication logic implementation is shown in the following block diagram. There are 10k pull-up resistors on the Module on the *SMARC USBx_EN_OC#* lines. Outputs driving the *USBx_EN_OC#* lines are open-drain. The Carrier board *USB* power switch, if present, is enabled by *USBx_EN_OC#* after a device connection is detected on the *DP/DM* lines.

The Enable pin on the Carrier board *USB* power switch must be active – high and the Over-Current pin (*OC#*) must be open drain, active low (these are commonly available). No pull-up is required on the *USB* power switch Enable or *OC#* line on carrier board; they are tied together on the Carrier and fed to the Module *USBx_EN_OC#* pin.

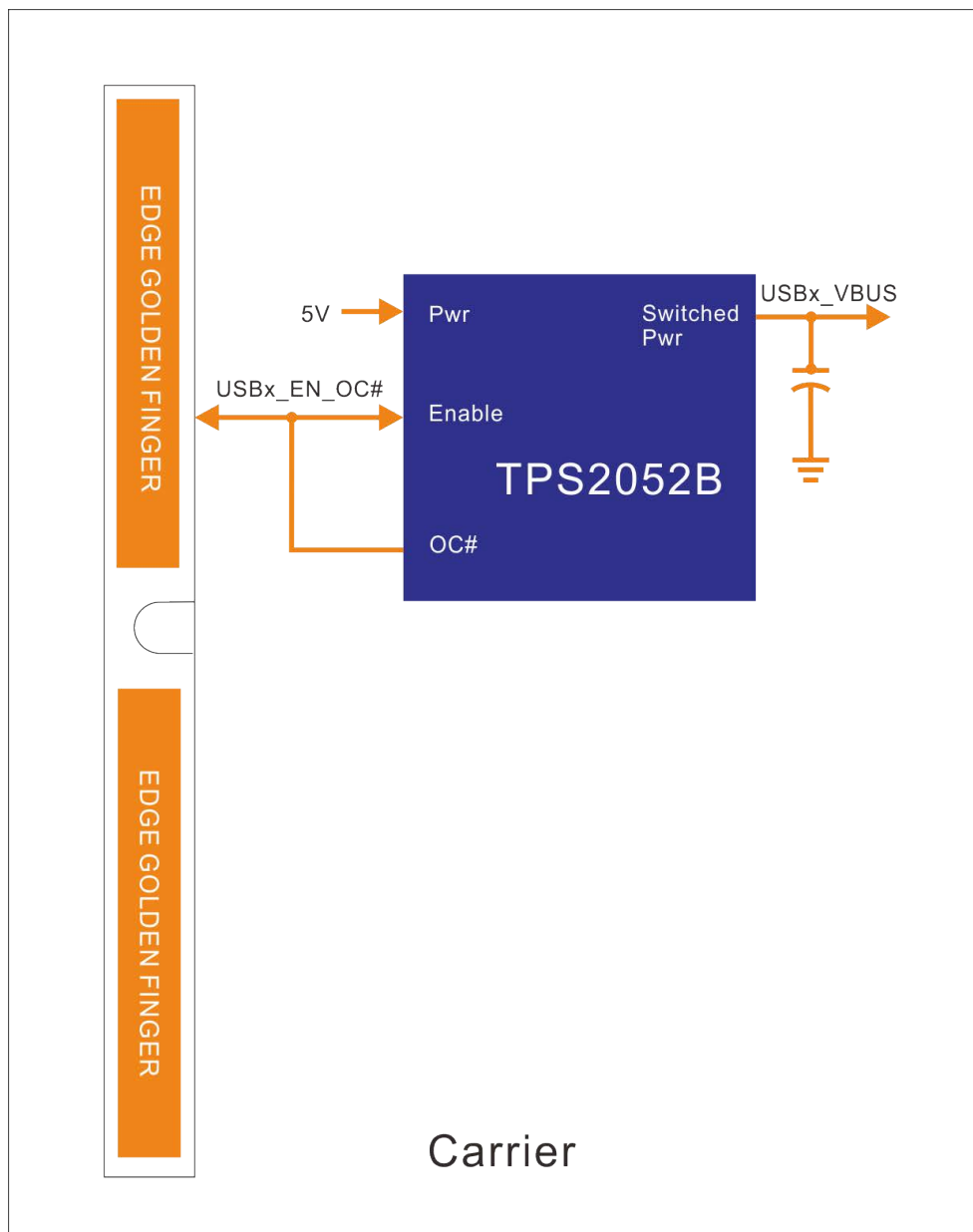

Figure 4. USB Power Distribution Implementation on Carrier

2.1.9. Gigabit Ethernet Controller (10/100/1000Mbps) Interface

The *SMARC* 2.0 pin-out supports two gigabit Ethernet capable ports. *SMARC-FiMX7-S* module supports one Gigabit Ethernet (10/100/1000Mbps) interfaces, and *SMARC-FiMX7-D* module supports two Gigabit Ethernet (10/100/1000Mbps) ports. The Gigabit Ethernet controller interfaces are accomplished by using the low-power Qualcomm Atheros *AR8035* physical layer (PHY) transceiver with variable I/O voltage that is compliant with the IEEE 802.3-2005 standards. The *AR8035* supports communication with an Ethernet MAC via a standard RGMII interface.

The Ethernet interface consists of 4 pairs of low voltage differential pair signals designated from *GBE0_MDI0±* to *GBE0_MDI3±* plus control signals for link activity indicators. These signals can be used to connect to a 10/100/1000 BaseT *RJ45* connector with integrated or external isolation magnetics on the carrier board.

This is diagrammed below.

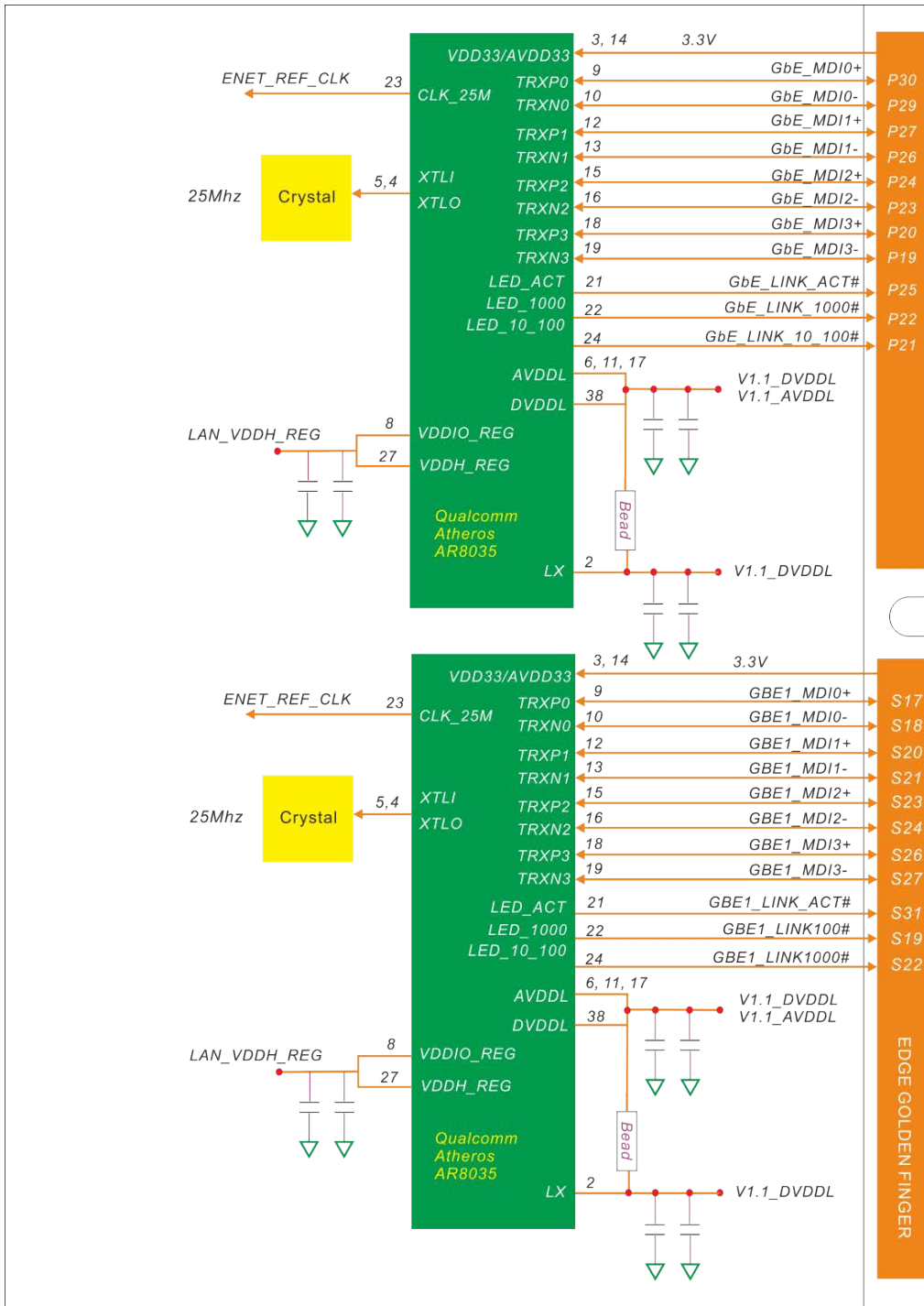

Figure 5: Gigabit Ethernet Connection from i.MX7 to Qualcomm Atheros AR8035

2.1.9.1. Path of Gigabit LAN1

i.MX7 processor and the first Qualcomm Atheros AR8035 implementation is shown in the following table:

Qualcomm/NXP i.MX7 CPU			Qualcomm AR8035		Net Names	Note
Ball	Mode	Pin Name	Pin#	Pin Name		
Gigabit LAN1						
R5	ALT2	GPIO1_I010__ ENET1_MDIO	39	MDIO	ENET_MDIO	Serial Management Interface data input/output
T1	ALT2	GPIO1_I011__ ENET1_MDC	40	MDC	ENET_MDC	Serial Management Interface clock
E14	ALTO	RGMII1_RD0__ RGMII1_RD0	29	RXD0	RGMII1_RD0	Bit 0 of the 4 data bits that are sent by the transceiver on the receive path.
F14	ALTO	RGMII1_RD1__ RGMII1_RD1	28	RXD1	RGMII1_RD1	Bit 1 of the 4 data bits that are sent by the transceiver on the receive path.
D13	ALTO	RGMII1_RD2__ RGMII1_RD2	26	RXD2	RGMII1_RD2	Bit 2 of the 4 data bits that are sent by the transceiver on the receive path.
E13	ALTO	RGMII1_RD3__ RGMII1_RD3	25	RXD3	RGMII1_RD3	Bit 3 of the 4 data bits that are sent by the transceiver on the receive path.
F15	ALTO	RGMII1_RXC__ RGMII1_RXC	31	RX_CLK	RGMII1_RXC	Reference clock
E15	ALTO	RGMII1_RX_CTL__ RGMII1_RX_CTL	30	RX_DV	RGMII1_RX_CTL	Indicates both the receive data valid (RXDV) and receive error (RXER) functions per the RGMII specification.

Qualcomm/NXP i.MX7 CPU			Qualcomm AR8035		Net Names	Note
Ball	Mode	Pin Name	Pin#	Pin Name		
Gigabit LAN1						
E16	ALTO	RGMI11_TX_CTL__ RGMI11_TX_CTL	32	TX_EN	RGMI11_TX_CTL	Indicates that valid transmission data is present on TXD[3:0].
F17	ALTO	RGMI11_TD0__ RGMI11_TD0	34	TXD0	RGMI11_TD0	The MAC transmits data to the transceiver using this signal.
E17	ALTO	RGMI11_TD1__ RGMI11_TD1	35	TXD1	RGMI11_TD1	The MAC transmits data to the transceiver using this signal.
E18	ALTO	RGMI11_TD2__ RGMI11_TD2	36	TXD2	RGMI11_TD2	The MAC transmits data to the transceiver using this signal.
D18	ALTO	RGMI11_TD3__ RGMI11_TD3	37	TXD3	RGMI11_TD3	The MAC transmits data to the transceiver using this signal.
F16	ALTO	RGMI11_TXC__ RGMI11_TXC	33	GTX_CLK	RGMI11_TXC	Used to latch data from the MAC into the PHY. 1000BASE-T: 125MHz 100BASE-TX: 25MHz 10BASE-T: 2.5MHz

Embedian, Inc.

The path from AR8035 to the golden finger edge connector is show in the following table.

Qualcomm AR8035		Golden Finger Edge Connector		Net Names	Note
Pin	Pin Name	Pin#	Pin Name		
AR8035 PHY1					
9	TRXP0	P30	GbE1_MDI0+	GBE0_MDI0+	Differential Transmit/Receive Positive Channel 0
10	TRXN0	P29	GbE1_MDI0-	GBE0_MDI0-	Differential Transmit/Receive Negative Channel 0
		P28	GbE1_CTREF	GBE0_CTREF	Center tap reference voltage
12	TRXP1	P27	GbE1_MDI1+	GBE0_MDI1+	Differential Transmit/Receive Positive Channel 1
13	TRXN1	P26	GbE1_MDI1-	GBE0_MDI1-	Differential Transmit/Receive Negative Channel 1
15	TRXP2	P24	GbE1_MDI2+	GBE0_MDI2+	Differential Transmit/Receive Positive Channel 2
16	TRXN2	P23	GbE1_MDI2-	GBE0_MDI2-	Differential Transmit/Receive Negative Channel 2
18	TRXP3	P20	GbE1_MDI3+	GBE0_MDI3+	Differential Transmit/Receive Positive Channel 3
19	TRXN3	P19	GbE1_MDI3-	GBE0_MDI3-	Differential Transmit/Receive Negative Channel 3

Qualcomm AR8035		Golden Finger Edge Connector		Net Names	Note
Pin	Pin Name	Pin#	Pin Name		
AR8035 PHY1					
21	LED_ACT	P25	GbE1_LINK_ACT#	GBE0_LINK_ACT#	<p>Link / Activity Indication LED</p> <p>Driven low on Link (10, 100 or 1000 mbps)</p> <p>Blinks on Activity</p> <p>Could be able to sink 24mA or more Carrier LED current</p>
24	LED_10_100	P21	GbE1_LINK100#	GBE0_LINK100#	<p>Link Speed Indication LED for 100Mbps</p> <p>Could be able to sink 24mA or more Carrier LED current</p>
22	LED_1000	P22	GbE1_LINK1000#	GBE0_LINK1000#	<p>Link Speed Indication LED for 1000Mbps</p> <p>Could be able to sink 24mA or more Carrier LED current</p>

2.1.9.2. Path of Gigabit LAN2 (Dual Core Only)

i.MX7 processor and the second Qualcomm Atheros AR8035 implementation is shown in the following table:

Qualcomm/NXP i.MX7 CPU			Qualcomm AR8035		Net Names	Note
Ball	Mode	Pin Name	Pin#	Pin Name		
Gigabit LAN 2						
R5	ALT2	GPIO1_I010__ ENET1_MDIO	39	MDIO	ENET_MDIO	Serial Management Interface data input/output
T1	ALT2	GPIO1_I011__ ENET1_MDC	40	MDC	ENET_MDC	Serial Management Interface clock
J21	ALT2	EPDC_SDCLK__ RGMII2_RD0	29	RXD0	RGMII2_RD0	Bit 0 of the 4 data bits that are sent by the transceiver on the receive path.
J20	ALT2	EPDC_SDLE__ RGMII2_RD1	28	RXD1	RGMII2_RD1	Bit 1 of the 4 data bits that are sent by the transceiver on the receive path.
H21	ALT2	EPDC_SDOE__ RGMII2_RD2	26	RXD2	RGMII2_RD2	Bit 2 of the 4 data bits that are sent by the transceiver on the receive path.
H20	ALT2	EPDC_SDSHR__ RGMII2_RD3	25	RXD3	RGMII2_RD3	Bit 3 of the 4 data bits that are sent by the transceiver on the receive path.
G24	ALT2	EPDC_SDCE1__ RGMII2_RXC	31	RX_CLK	RGMII2_RXC	Reference clock
G25	ALT2	EPDC_SDCE0__ RGMII2_RX_CTL	30	RX_DV	RGMII2_RX_CTL	Indicates both the receive data valid (RXDV) and receive error (RXER) functions per the RGMII specification.

Qualcomm/NXP i.MX7 CPU			Qualcomm AR8035		Net Names	Note
Ball	Mode	Pin Name	Pin#	Pin Name		
Gigabit LAN 2						
K21	ALT2	EPDC_GDRL__ RGMII2_TX_CTL	32	TX_EN	RGMII2_TX_CTL	Indicates that valid transmission data is present on TXD[3:0].
H23	ALT2	EPDC_SDCE2__ RGMII2_TD0	34	TXD0	RGMII2_TD0	The MAC transmits data to the transceiver using this signal.
H22	ALT2	EPDC_SDCE3__ RGMII2_TD1	35	TXD1	RGMII2_TD1	The MAC transmits data to the transceiver using this signal.
J25	ALT2	EPDC_GDCLK__ RGMII2_TD2	36	TXD2	RGMII2_TD2	The MAC transmits data to the transceiver using this signal.
J24	ALT2	EPDC_GDOE__ RGMII2_TD3	37	TXD3	RGMII2_TD3	The MAC transmits data to the transceiver using this signal.
H25	ALT2	EPDC_GDSP__ RGMII2_TXC	33	GTX_CLK	RGMII2_TXC	Used to latch data from the MAC into the PHY. 1000BASE-T: 125MHz 100BASE-TX: 25MHz 10BASE-T: 2.5MHz

Embedian, Inc.

The path from the second AR8035 to the golden finger edge connector is show in the following table.

Qualcomm AR8035		Golden Finger Edge Connector		Net Names	Note
Pin	Pin Name	Pin#	Pin Name		
AR8035 PHY 2					
9	TRXP0	S17	GBE1_MDI0+	GBE1_MDI0+	Differential Transmit/Receive Positive Channel 0
10	TRXN0	S18	GBE1_MDI0-	GBE1_MDI0-	Differential Transmit/Receive Negative Channel 0
		S28	GBE1_CTREF	GBE1_CTREF	Center tap reference voltage
12	TRXP1	S20	GBE1_MDI1+	GBE1_MDI1+	Differential Transmit/Receive Positive Channel 1
13	TRXN1	S21	GBE1_MDI1-	GBE1_MDI1-	Differential Transmit/Receive Negative Channel 1
15	TRXP2	S23	GBE1_MDI2+	GBE1_MDI2+	Differential Transmit/Receive Positive Channel 2
16	TRXN2	S24	GBE1_MDI2-	GBE1_MDI2-	Differential Transmit/Receive Negative Channel 2
18	TRXP3	S26	GBE1_MDI3+	GBE1_MDI3+	Differential Transmit/Receive Positive Channel 3
19	TRXN3	S27	GBE1_MDI3-	GBE1_MDI3-	Differential Transmit/Receive Negative Channel 3

Qualcomm AR8035		Golden Finger Edge Connector		Net Names	Note
Pin	Pin Name	Pin#	Pin Name		
AR8035 PHY 2					
21	LED_ACT	S31	GBE1_LINK_ACT#	GBE1_LINK_ACT#	<p>Link / Activity Indication LED</p> <p>Driven low on Link (10, 100 or 1000 mbps)</p> <p>Blinks on Activity</p> <p>Could be able to sink 24mA or more Carrier LED current</p>
24	LED_10_100	S19	GBE1_LINK100#	GBE1_LINK100#	<p>Link Speed Indication LED for 100Mbps</p> <p>Could be able to sink 24mA or more Carrier LED current</p>
22	LED_1000	S22	GBE1_LINK1000#	GBE1_LINK1000#	<p>Link Speed Indication LED for 1000Mbps</p> <p>Could be able to sink 24mA or more Carrier LED current</p>

2.1.9.3. Gigabit LAN Signals

The table below shows the Gigabit LAN related signals.

Edge Golden Finder Signal Name	Direction	Type Tolerance	Description
GBE0(1)_MDI0+ GBE0(1)_MDI0-	Bi-Dir	GBE_MDI	Bi-directional transmit/receive pair 0 to magnetics (Media Dependent Interface)
GBE0(1)_MDI1+ GBE0(1)_MDI1-	Bi-Dir	GBE_MDI	Bi-directional transmit/receive pair 1 to magnetics (Media Dependent Interface)
GBE0(1)_MDI2+ GBE0(1)_MDI2-	Bi-Dir	GBE_MDI	Bi-directional transmit/receive pair 2 to magnetics (Media Dependent Interface)
GBE0(1)_MDI3+ GBE0(1)_MDI3-	Bi-Dir	GBE_MDI	Bi-directional transmit/receive pair 3 to magnetics (Media Dependent Interface)
GBE0(1)_100#	Output OD	CMOS 3.3V	Link Speed Indication LED for 100Mbps Could be able to sink 24mA or more Carrier LED current
GBE0(1)_1000#	Output OD	CMOS 3.3V	Link Speed Indication LED for 1000Mbps Could be able to sink 24mA or more Carrier LED current
GBE0(1)_LINK_ACK#	Output OD	CMOS 3.3V	Link / Activity Indication LED Driven low on Link (10, 100 or 1000 mbps) Blinks on Activity Could be able to sink 24mA or more Carrier LED current
GBE0(1)_CTREF	Output	Reference Voltage	Center-Tap reference voltage for GBE0 Carrier board Ethernet magnetic (not required by the Module GBE PHY)

Embedian, Inc.

2.1.9.4. Suggested Magnetics

Listed below are suggested magnetics.

For normal temperature (0°C ~70°C) products.

<i>Vendor</i>	<i>P/N</i>	<i>Package</i>	<i>Cores</i>	<i>Temp</i>	<i>Configuration</i>
<i>Halo</i>	<i>HFJ11-1G02E</i>	<i>Integrated RJ45</i>	<i>8</i>	<i>0°C~70°C</i>	<i>HP Auto-MDIX</i>
<i>UDE</i>	<i>RB1-BA6BT9WA</i>	<i>Integrated RJ45</i>	<i>8</i>	<i>-40°C~85°C</i>	<i>HP Auto-MDIX</i>
<i>Halo</i>	<i>TG1G-S002NZRL</i>	<i>24-pin SOIC-W</i>	<i>8</i>	<i>0°C~70°C</i>	<i>HP Auto-MDIX</i>

For industrial temperature (-40°C ~85°C) products.

<i>Vendor</i>	<i>P/N</i>	<i>Package</i>	<i>Cores</i>	<i>Temp</i>	<i>Configuration</i>
<i>UDE</i>	<i>RB1-BA6BT9WA</i>	<i>Integrated RJ45</i>	<i>8</i>	<i>-40°C~85°C</i>	<i>HP Auto-MDIX</i>
<i>Halo</i>	<i>TG1G-E012NZRL</i>	<i>24-pin SOIC-W</i>	<i>8</i>	<i>-40°C~85°C</i>	<i>HP Auto-MDIX</i>

2.1.10. PCIe Interface (Dual Core Only)

The *SMARC-FiMX7-D* offers one *PCI Express* lane. The *PCIe* signals are routed from the Qualcomm/NXP® *i.MX7* processor to the *PCI Express* port A of the *SMARC-FiMX7* edge finger. These signals support *PCI Express* Gen. 2.1 interfaces at 5 Gb/s and are backward compatible to Gen. 1.1 interfaces at 2.5 Gb/s. Only x1 *PCI Express* link configuration is possible.

The following figure shows the *PCIe* port A block diagram.

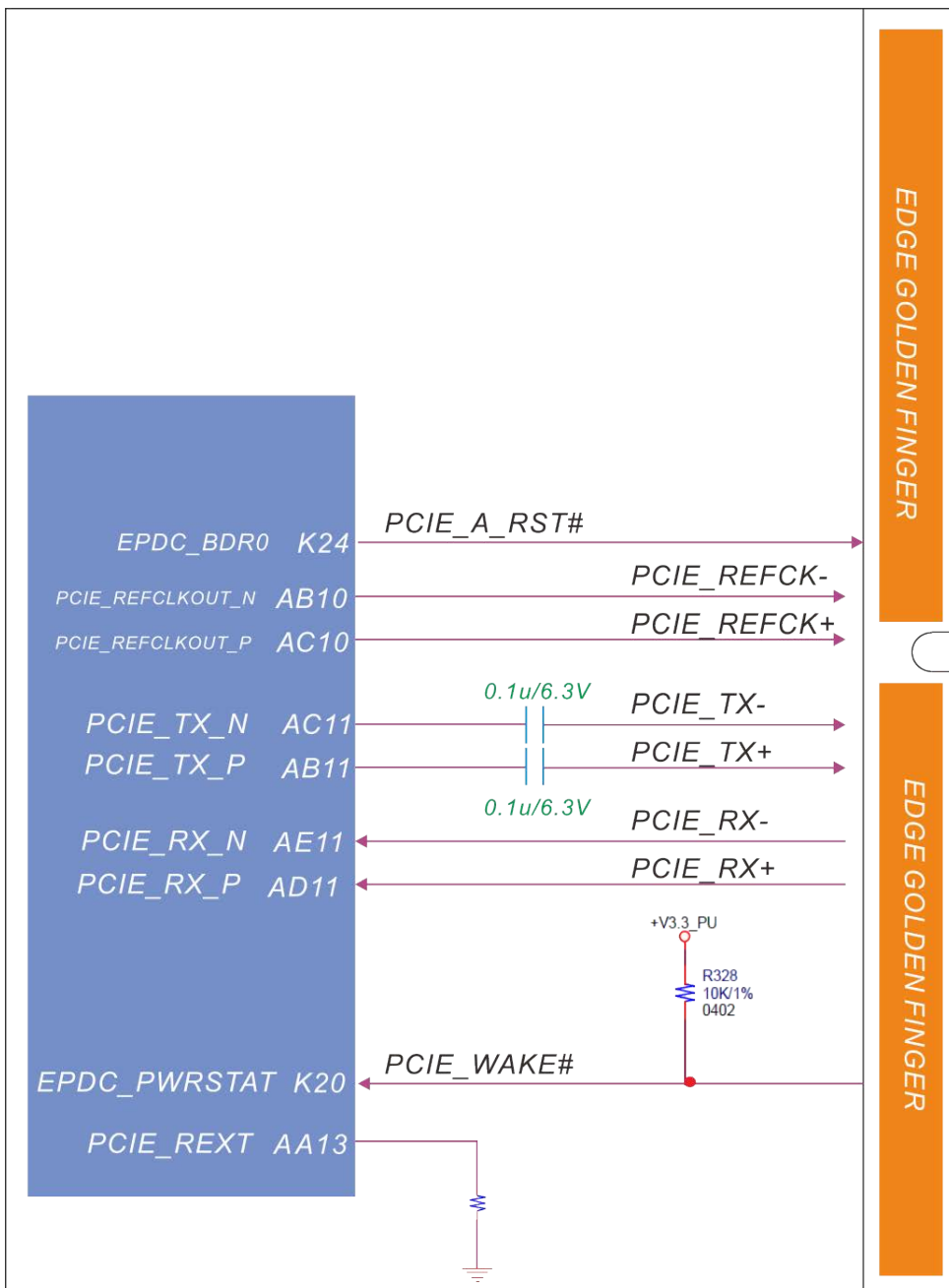

Figure 6. PCI Express Block Diagram SMARC-

Embedian, Inc.

PCI Express interface signals are exposed on the SMARC-FiMX7 edge connector as shown below:

Qualcomm/NXP i.MX7 CPU			SMARC-FiMX7 Edge Golden Finger		Net Names	Note
Ball	Mode	Pin Name	Pin#	Pin Name		
<i>PCI Express Port A</i>						
K24	ALT5	EPDC_BDR0__ GPIO2_I028	P75	PCIE_A_RST#	PCIE_A_RST#	Reset Signal for external devices.
AC10		PCIE_REFCLKOUT_P	P83	PCIE_A_REFCK+	PCIE_A_REFCK+	Differential PCI Express Reference Clock Signals for Lanes A
AB10		PCIE_REFCLKOUT_N	P84	PCIE_A_REFCK-	PCIE_A_REFCK-	
AD11		PCIE_RX_P	P86	PCIE_A_RX+	PCIE_A_RX+	Differential PCIe Link A receive data pair 0
AE11		PCIE_RX_N	P87	PCIE_A_RX-	PCIE_A_RX-	
AB11		PCIE_TX_P	P89	PCIE_A_TX+	PCIE_A_TX+	Differential PCIe Link A transmit data pair 0
AC11		PCIE_TX_N	P90	PCIE_A_TX-	PCIE_A_TX-	
K20	ALT5	EPDC_PWRSTAT__ GPIO2_I031	S146	PCIE_WAKE#	PCIE_WAKE#	PCI Express Wake Event: Sideband wake signal asserted by components requesting wakeup.

2.1.10.1. PCIe_Link A Signals

The table below shows the *PCIe_Link A* related signals.

<i>Edge Golden Finder Signal Name</i>	<i>Direction</i>	<i>Type Tolerance</i>	<i>Description</i>
<i>PCIE_A_TX+ PCIE_A_TX-</i>	<i>Output</i>	<i>LVDS PCIe</i>	<i>Differential PCIe Link A transmit data pair 0 Series coupling caps is on the Module Caps is 0402 package 0.1uF</i>
<i>PCIE_A_RX+ PCIE_A_RX-</i>	<i>Input</i>	<i>LVDS PCIe</i>	<i>Differential PCIe Link A receive data pair 0 No coupling caps on Module</i>
<i>PCIE_A_REFCK+ PCIE_A_REFCK-</i>	<i>Output</i>	<i>LVDS PCIe</i>	<i>Differential PCIe Link A reference clock output DC coupled</i>
<i>PCIE_A_RST#</i>	<i>Output</i>	<i>CMOS 3.3V</i>	<i>PCIe Port A reset output</i>

2.1.10.2. PCIe Wake Signals

The table below shows the *PCIe Wake* signal.

<i>Edge Golden Finder Signal Name</i>	<i>Direction</i>	<i>Type Tolerance</i>	<i>Description</i>
<i>PCIE_WAKE#</i>	<i>Input</i>	<i>CMOS 3.3V</i>	<i>PCIe wake up interrupt to host – common to PCIe links A, B, C – pulled up or terminated on Module</i>

2.1.11. MIPI/CMOS Serial Camera Interface

The *Qualcomm/NXP® i.MX7* processor provides connectivity to cameras via the *MIPI/CSI-2* transmitter and maintains image manipulation and processing with adequate synchronization and control. The Camera Serial Interface (*CSI*) controls the camera port and provides interface to an image sensor or a related device. The role of the camera ports is to receive input from video sources and to provide support for time-sensitive signals to the camera. Non-time-sensitive controls such as configuration, reset are performed by the ARM platform through I2C interface or GPIO signals. There is one instance of *CSI-2* port in the *i.MX7* Dual application processor. This interface support from 80 Mbps up to 1.5 Gbps speed per data lane. The *CSI-2* Receiver core can manage one clock lane and up to two data lanes through the lane management and de-packetization, providing a maximum throughput of 3 Gbps transfer rate.

The camera interface on *SMARC-FiMX7* is designed as serial interfaces on *CSI1* pin groups that can support 2 lanes. The *CSI0* interface is not connected on edge golden finger connector.

The following figure shows the serial camera interface block diagram.

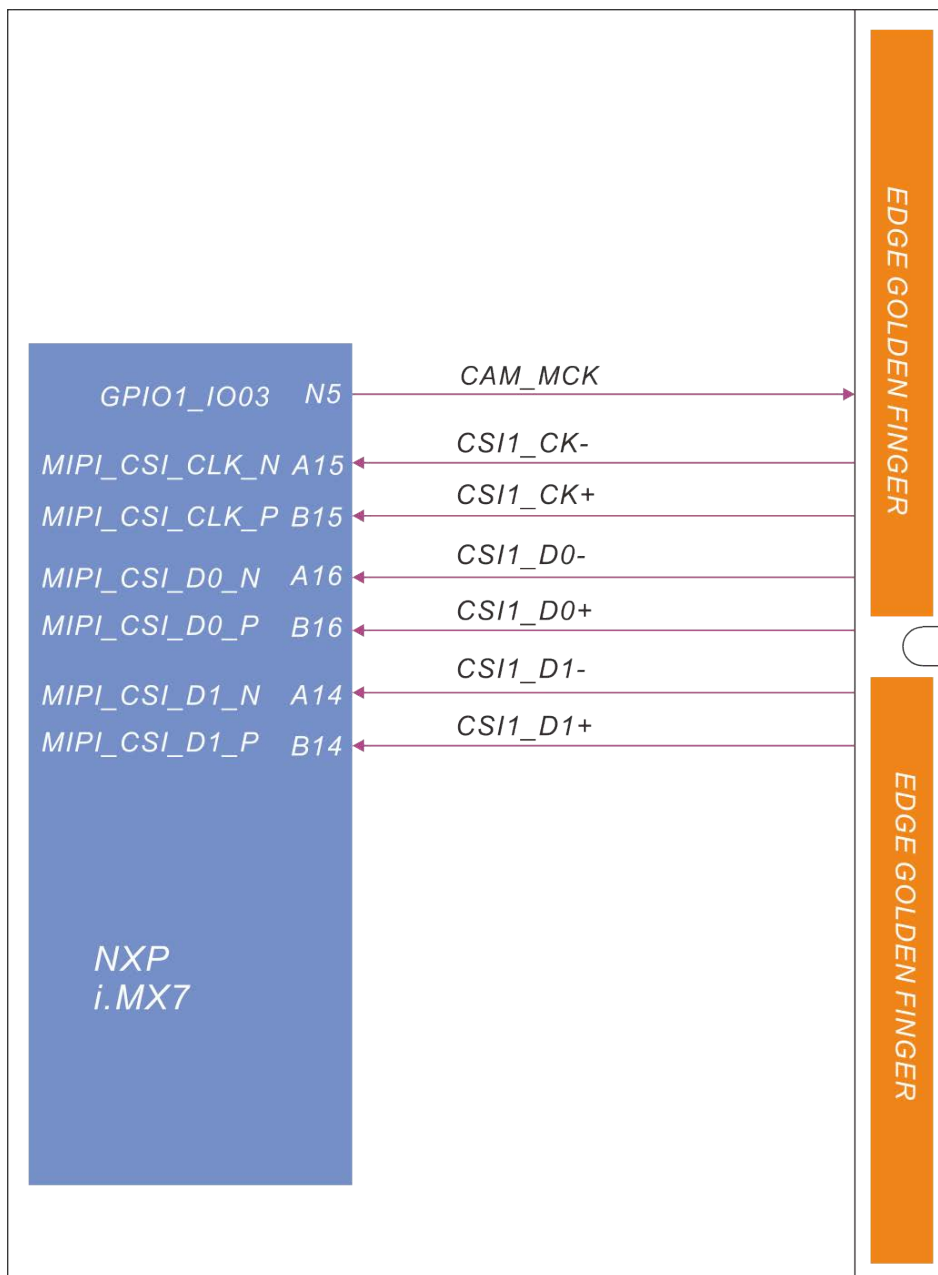

Figure 7. MIPI/Serial Camera Interface Block Diagram

Embedian, Inc.

MIPI/Serial Camera interface signals are exposed on the *SMARC-FiMX7* edge connector as shown below:

Qualcomm/NXP i.MX7 CPU			SMARC-FiMX7 Edge Golden Finger		Net Names	Note
Ball	Mode	Pin Name	Pin#	Pin Name		
<i>MIPI/Serial Camera Interface</i>						
N5	ALT5	GPI01_I003__ CCM_CLK02	S6	CAM_MCK	CAM_MCK	Master clock output for CSI camera support
A15		MIPI_CSI_CLK_N	P4	CSI1_CK-	CSI1_CK-	CSI1 differential clock inputs
B15		MIPI_CSI_CLK_P	P3	CSI1_CK+	CSI1_CK+	
A16		MIPI_CSI_D0_N	P8	CSI1_RX0-	CSI1_D0-	CSI1 differential data inputs
B16		MIPI_CSI_D0_P	P7	CSI1_RX0+	CSI1_D0+	
A14		MIPI_CSI_D1_N	P11	CSI1_D1-	CSI1_D1-	
B14		MIPI_CSI_D1_P	P10	CSI1_D1+	CSI1_D1+	

2.1.11.1. Camera I2C Support

The *I2C_CAM* port is intended to support serial and parallel cameras. Most contemporary cameras with *I2C* support allow a choice of two *I2C* address ranges.

<i>Edge Golden Finder Signal Name</i>	<i>Direction</i>	<i>Type Tolerance</i>	<i>Description</i>
<i>I2C_CAM1_DAT</i>	<i>Bi-Dir OD</i>	<i>CMOS 1.8V</i>	<i>Serial / Parallel camera support link - I2C data</i>
<i>I2C_CAM1_CK</i>	<i>Bi-Dir OD</i>	<i>CMOS 1.8V</i>	<i>Differential SATA 0 transmit data</i> <i>Series coupling caps is on the Module</i> <i>Caps is 0402 package 0.1uF</i>

2.1.11.2. Serial Camera In – CSI1

<i>Edge Golden Finder Signal Name</i>	<i>Direction</i>	<i>Type Tolerance</i>	<i>Description</i>
<i>CSI1_D[0:1]+ CSI1_D[0:1]-</i>	<i>Input</i>	<i>LVDS D-PHY</i>	<i>CSI1 differential data inputs</i>
<i>CSI1_CK+ CSI1_CK-</i>	<i>Input</i>	<i>LVDS D-PHY</i>	<i>CSI1 differential clock inputs</i>
<i>CAM_MCK</i>	<i>Output</i>	<i>CMOS 1.8V</i>	<i>Master clock output for CSI1 camera support</i>

2.1.12. SD/SDIO Interface

SMARC-FiMX7 is configured to support two MMC controllers. One is used for on-module 8-bit eMMC support, and the other one is used for external SDHC/SDIO interface. The SMARC-FiMX7 module supports one 4-bit SDIO interface, per the SMARC 2.0 specification. The SDIO interface uses 3.3V signaling, per the SMARC spec and for compatibility with commonly available SDIO cards.

The following figure shows the SDIO/eMMC block diagram.

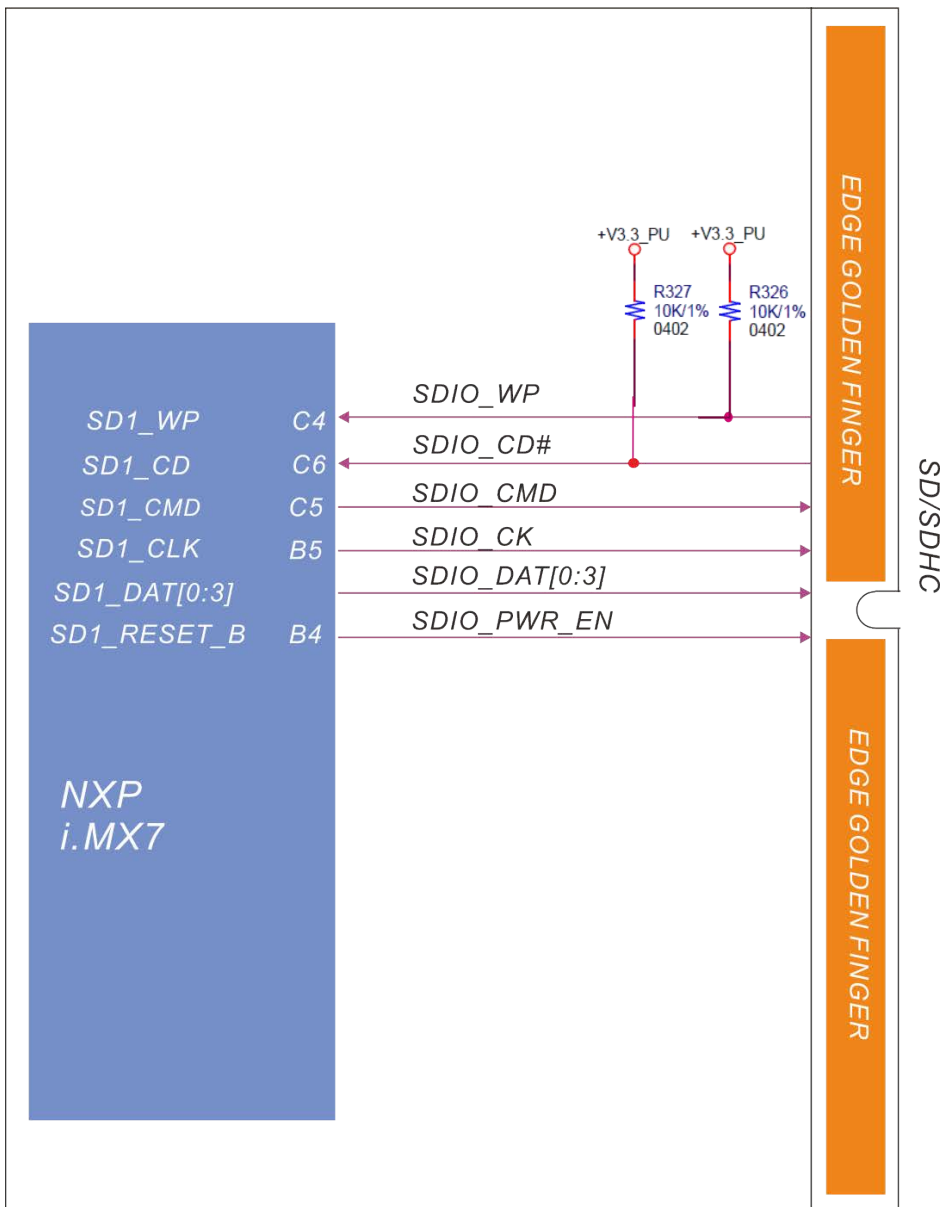

Figure 8. SD/SDIO/eMMC Interface Block Diagram

Embedian, Inc.

SDIO and SDMMC interface signals are exposed on the SMARC golden finger edge connector as shown below:

Qualcomm/NXP i.MX7 CPU			SMARC-FiMX7 Edge Golden Finger		Net Names	Note
Ball	Mode	Pin Name	Pin#	Pin Name		
SD/SDIO						
A5	ALT0	SD1_DATA0__ SD1_DATA0	P39	SDIO_D0	SDIO_D0	SDIO Data 0
D6	ALT0	SD1_DATA1__ SD1_DATA1	P40	SDIO_D1	SDIO_D1	SDIO Data 1
A4	ALT0	SD1_DATA2__ SD1_DATA2	P41	SDIO_D2	SDIO_D2	SDIO Data 2
D5	ALT0	SD1_DATA3__ SD1_DATA3	P42	SDIO_D3	SDIO_D3	SDIO Data 3
C4	ALT0	SD1_WP__ SD1_WP	P33	SDIO_WP	SDIO_WP	SDIO write protect signal
C5	ALT0	SD1_CMD__ SD1_CMD	P34	SDIO_CMD	SDIO_CMD	SDIO Command signal
C6	ALT0	SD1_CD__ SD1_CD	P35	SDIO_CD#	SDIO_CD#	SDIO card detect
B5	ALT0	SD1_CLK__ SD1_CLK	P36	SDIO_CK	SDIO_CK	SDIO Clock Signal
B4	ALT0	SD1_RESET_B__ SD1_RESET_B	P37	SDIO_PWR_EN	SDIO_PWREN	SD card power enable

Note:

1. The SDIO card power should be switched on the Carrier board and the SDIO lines should be ESD protected. The SMARC Evaluation Carrier schematic is useful as an implementation reference.
2. If SD boot up function is required, the pull-up resistor to 3.3V of SDIO_PWR_EN # should be 4.7k or less.
3. SDIO_WP and SDIO_CD# are 10k pull up to 3.3V on module.

2.1.12.1. SDIO Card (4 bit) Interface

The Carrier SDIO Card can be selected as the Boot Device (See section 4.3).

<i>Edge Golden Finder Signal Name</i>	<i>Direction</i>	<i>Type Tolerance</i>	<i>Description</i>
<i>SDIO_D[0:3]</i>	<i>Bi-Dir</i>	<i>CMOS 3.3V</i>	<i>4 bit data path</i>
<i>SDIO_CMD</i>	<i>Bi-Dir</i>	<i>CMOS 3.3V</i>	<i>Command Line</i>
<i>SDIO_CK</i>	<i>Output</i>	<i>CMOS 3.3V</i>	<i>Clock</i>
<i>SDIO_WP</i>	<i>Input</i>	<i>CMOS 3.3V</i>	<i>Write Protect</i>
<i>SDIO_CD#</i>	<i>Input</i>	<i>CMOS 3.3V</i>	<i>Card Detect</i>
<i>SDIO_PWR_EN</i>	<i>Output</i>	<i>CMOS 3.3V</i>	<i>SD Card Power Enable</i>

Note:

SD Cards are not typically available with a 1.8V I/O voltage. The Module SD Card I/O level is specified as 3.3V and **not** CMOS 1.8V.

2.1.13. SPI Interface

The *SMARC-FiMX7* module supports two *Qualcomm/NXP i.MX7* SPI interfaces that are available off-Module for general purpose use. Each SPI channel has two chip-selects that can connect two SPI slave devices on each channel. Every device will share the "SPI_DIN", "SPI_DO" and "SPI_CK" pins, but each device will have its own chip select pin. The chip select signal is a low active signal.

The 4MB onboard *SPI NOR* flash uses an independent *SPI* interface with different chip select signal. The onboard *SPI NOR* flash on *SMARC-FiMX7* is used as first stage bootloader device. The module will always boot up from *SPI NOR* flash (if *TEST#* pin is floating), and the firmware (first stage bootloader) in *NOR* flash will read the *BOOT_SEL* configuration and load the second stage bootloader from the user assigned Boot Device.

The SPI interface is diagramed below.

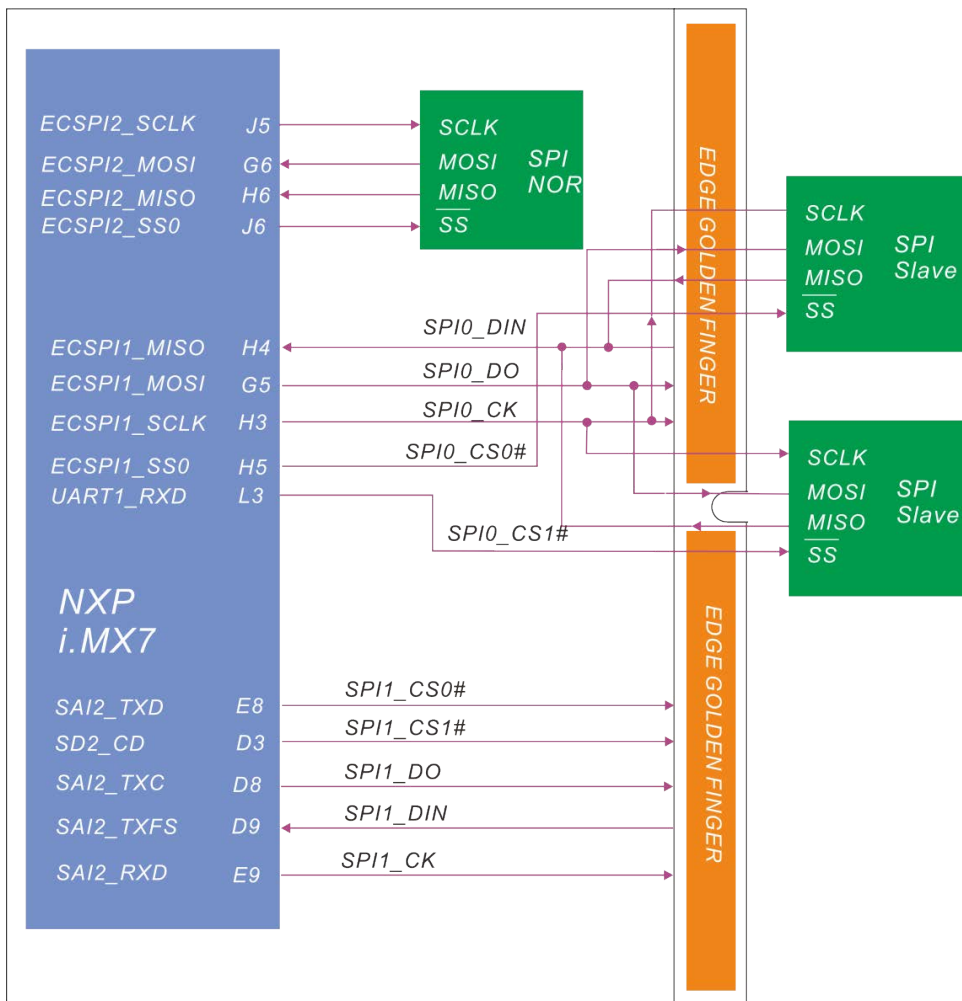

Figure 9: SPI Serial Flash Schematics

Embedian, Inc.

SPI interface signals are exposed on the SMARC golden finger edge connector as shown below:

Qualcomm/NXP i.MX7 CPU			SMARC-FiMX7 Edge Golden Finger		Net Names	Note
Ball	Mode	Pin Name	Pin#	Pin Name		
SPI NOR Flash						
J6	ALT0	ECSPI2_SS0__ ECSPI2_SS0				Chip select for SPI NOR Flash
J5	ATL0	ECSPI2_SCLK__ ECSPI2_SCLK				SPI_NOR Master Clock output
G6	ALT0	ECSPI2_MOSI__ ECSPI2_MOSI				SPI_NOR Master Data input (input to CPU, output from SPI device)
H6	ALT0	ECSPI2_MISO__ ECSPI2_MISO				SPI_NOR Master Data output (output from CPU, input to SPI device)

Qualcomm/NXP i.MX7 CPU			SMARC-FiMX7 Edge Golden Finger		Net Names	Note
Ball	Mode	Pin Name	Pin#	Pin Name		
SPI0 Port						
H5	ALT0	ECSPI1_SS0__ ECSPI1_SS0	P43	SPI0_CS0#	SPI0_CS0#	SPI0 Master Chip Select 0 output
L3	ALT3	UART1_RXD__ ECSPI1_SS1	P31	SPI0_CS1#	SPI0_CS1#	SPI0 Master Chip Select 1 output
H3	ALT0	ECSPI1_SCLK_ ECSPI1_SCLK	P44	SPI0_CK	SPI0_SCLK	SPI0 Master Clock output
H4	ALT0	ECSPI1_MISO__ ECSPI1_MISO	P45	SPI0_DIN	SPI0_DIN	SPI0 Master Data input (input to CPU, output from SPI device)
G5	ALT0	ECSPI1_MOSI__ ECSPI1_MOSI	P46	SPI0_DO	SPI0_DO	SPI0 Master Data output (output from CPU, input to SPI device)
SPI1 Port						
E8	ALT1	SAI2_TXD__ ECSPI1_SS0	P54	ESPI1_CS0#	ESPI1_CS0#	SPI1 Master Chip Select 0 output
D3	ALT3	SD2_CD_B__ ECSP3_SS2	P55	ESPI1_CS1#	ESPI1_CS1#	SPI1 Master Chip Select 1 output
E9	ALT1	SAI2_RXD__ ECSPI1_SCLK	P56	ESPI1_CK	ESPI1_SCLK	SPI1 Master Clock output
D9	ALT1	SAI2_TXFS__ ECSPI3_MISO	P57	ESPI1_IO_0	ESPI1_IO_0	SPI1 Master Data input (input to CPU, output from SPI device)
D8	ALT1	SAI2_TXC__ ECSPI3_MOSI	P58	ESPI1_IO_1	ESPI1_IO_1	SPI1 Master Data output (output from CPU, input to SPI device)

2.1.13.1. SPI0 Signals

The Carrier SPI0 device may be selected as the Boot Device – see Section 4.3 Boot Select.

<i>Edge Golden Finder Signal Name</i>	<i>Direction</i>	<i>Type Tolerance</i>	<i>Description</i>
<i>SPI0_CS0#</i>	<i>Output</i>	<i>CMOS 1.8V</i>	<i>SPI0 Master Chip Select 0 output</i>
<i>SPI0_CS1#</i>	<i>Output</i>	<i>CMOS 1.8V</i>	<i>SPI0 Master Chip Select 1 output</i>
<i>SPI0_CK</i>	<i>Output</i>	<i>CMOS 1.8V</i>	<i>SPI0 Master Clock output</i>
<i>SPI0_DIN</i>	<i>Input</i>	<i>CMOS 1.8V</i>	<i>SPI0 Master Data input (input to CPU, output from SPI device)</i>
<i>SPI0_DO</i>	<i>Output</i>	<i>CMOS 1.8V</i>	<i>SPI0 Master Data output (output from CPU, input to SPI device)</i>

2.1.13.2. SPI1 Signals

<i>Edge Golden Finder Signal Name</i>	<i>Direction</i>	<i>Type Tolerance</i>	<i>Description</i>
<i>SPI1_CS0#</i>	<i>Output</i>	<i>CMOS 1.8V</i>	<i>SPI1 Master Chip Select 0 output</i>
<i>SPI1_CS1#</i>	<i>Output</i>	<i>CMOS 1.8V</i>	<i>SPI1 Master Chip Select 1 output</i>
<i>SPI1_CK</i>	<i>Output</i>	<i>CMOS 1.8V</i>	<i>SPI1 Master Clock output</i>
<i>SPI1_DIN</i>	<i>Input</i>	<i>CMOS 1.8V</i>	<i>SPI1 Master Data input (input to CPU, output from SPI device)</i>
<i>SPI1_DO</i>	<i>Output</i>	<i>CMOS 1.8V</i>	<i>SPI1 Master Data output (output from CPU, input to SPI device)</i>

2.1.14. I2S Interface

The *SMARC-FiMX7* module uses *I2S* format for Audio signals. These signals are derived from the Synchronous Audio Interface (SAI) of the *Qualcomm/NXP® i.MX7* processor. The *SAI* is a full duplex serial port that allows communication with external devices using a variety of serial protocols. The *I2S* protocol is part of the protocols supported by the *Qualcomm/NXP® i.MX7* Cortex A7 processor.

I2S interface signals are exposed on the *SMARC-FiMX7* golden finger edge connector as shown below:

Qualcomm/NXP i.MX7 CPU			SMARC-FiMX7 Edge Golden Finger		Net Names	Note
Ball	Mode	Pin Name	Pin#	Pin Name		
E10	ALT0	SAI1_MCLK__ SAI1_MCLK	S38	Audio_MCK	AUD_MCLK	Master clock output to Audio codecs
D11	ALT0	SAI1_TXFS__ SAI1_TXFS	S39	I2S0_LRCK	I2S0_LRCK	Left& Right audio synchronization clock
E11	ALT0	SAI1_TXD__ SAI1_TXD	S40	I2S0_SDOUT	I2S0_SDOUT	Digital audio Output
E12	ALT0	SAI1_RXD__ SAI1_RXD	S41	I2S0_SDIN	I2S0_SDIN	Digital audio Input
C11	ALT0	SAI1_TXC__ SAI1_TXC	S42	I2S0_CK	I2S0_CK	Digital audio clock

Note:

SMARC-FiMX7 currently supports only *I2S* format. *SGTL5000 I2S* audio codec is used in *EVK-STD-CARRIER* and *EVKS2-STD-CARRIER* evaluation carrier board. An external 24.576 Mhz crystal is used as a reference clock output to audio codec instead of Pin S38. Theoretically, both ways will work.

2.1.14.1 I2S0 Signals

<i>Edge Golden Finder Signal Name</i>	<i>Direction</i>	<i>Type Tolerance</i>	<i>Description</i>
<i>I2S0_LRCK</i>	<i>Bi-Dir</i>	<i>CMOS 1.8V</i>	<i>Left& Right audio synchronization clock</i>
<i>I2S0_SDOUT</i>	<i>Output</i>	<i>CMOS 1.8V</i>	<i>Digital audio Output</i>
<i>I2S0_SDIN</i>	<i>Input</i>	<i>CMOS 1.8V</i>	<i>Digital audio Input</i>
<i>I2S0_CK</i>	<i>Bi-Dir</i>	<i>CMOS 1.8V</i>	<i>Digital audio clock</i>
<i>I2S0_MCK</i>	<i>Output</i>	<i>CMOS 1.8V</i>	<i>Master clock output to Audio codecs</i>

2.1.15. Asynchronous Serial Port

The *SMARC-FiMX7* module supports four *UARTs* (*SER0:3*). *SER0* and *SER2* support flow control signals (*RTS#*, *CTS#*). *SER1* and *SER3* do not support flow control (*TX*, *RX* only). When working with software, *SER 3* is used for *SMARC-FiMX7* debugging console port.

The module asynchronous serial port signals have a *VDDIO* (1.8V) level signal swing. They can be converted to RS232 level and polarity signals by using a suitable RS232 transceiver. Almost all transceivers available accept a 3.3V signal level: example include the Texas Instruments *MAX3243*. Note that RS232 transceivers invert the signal; a logic '1' is a negative voltage (-3.0V to -15V) and a logic '0' a positive voltage (3.0V to 15V) on the *RS232* line. Since *SMARC 2.0* specification defines 1.8V *VDDIO* module, a level-shift IC from 1.8V to 3.3V might be required.

Embedian, Inc.

Asynchronous serial ports interface signals are exposed on the SMARC golden finger edge connector as shown below:

Qualcomm/NXP i.MX7 CPU			SMARC-FiMX7 Edge Golden Finger		Net Names	Note
Ball	Mode	Pin Name	Pin#	Pin Name		
SER0 Port						
L25	ALT3	EPDC_DATA09__ UART6_TX_DATA	P129	SER0_TX	SER0_TX	Asynchronous serial port data out
M23	ALT3	EPDC_DATA08__ UART6_RX_DATA	P130	SER0_RX	SER0_RX	Asynchronous serial port data in
L24	ALT3	EPDC_DATA10__ UART6_RTS_B	P131	SER0_RTS#	SER0_RTS#	Request to Send handshake line for SER0
L23	ALT3	EPDC_DATA11__ UART6_CTS_B	P132	SER0_CTS#	SER0_CTS#	Clear to Send handshake line for SER0
SER1 Port						
L6	ALT0	UART2_TX_DATA__ UART2_TX_DATA	P134	SER1_TX	SER1_TX	Asynchronous serial port data out
L5	ALT0	UART2_RX_DATA__ UART2_RX_DATA	P135	SER1_RX	SER1_RX	Asynchronous serial port data in
SER2 Port						
L21	ALT3	EPDC_DATA13__ UART7_TX_DATA	P136	SER2_TX	SER2_TX	Asynchronous serial port data out
L22	ALT3	EPDC_DATA12__ UART7_RX_DATA	P137	SER2_RX	SER2_RX	Asynchronous serial port data in
L20	ALT3	EPDC_DATA14__ UART7_RTS_B	P138	SER2_RTS#	SER2_RTS#	Request to Send handshake line for SER2
K25	ALT3	EPDC_DATA15__ UART7_CTS_B	P139	SER2_CTS#	SER2_CTS#	Clear to Send handshake line for SER2
SER3 Port (Debugging Port)						
M2	ALT0	UART3_TX_DATA__ UART3_TX_DATA	P140	SER3_TX	SER3_TX	Asynchronous serial port data out
M1	ALT0	UART3_RX_DATA__ UART3_RX_DATA	P141	SER3_RX	SER3_RX	Asynchronous serial port data in

2.1.15.1. UART Signals

Module pins for up to four asynchronous serial ports are defined. The ports are designated *SER0* – *SER3*. Ports *SER0* and *SER2* are 4 wire ports (2 data lines and 2 handshake lines). Ports *SER1* and *SER3* are 2 wire ports (data only).

Edge Golden Finder Signal Name	Direction	Type Tolerance	Description
<i>SER[0:3]_TX</i>	<i>Output</i>	<i>CMOS 1.8V</i>	<i>Asynchronous serial port data out</i>
<i>SER[0:3]_RX</i>	<i>Input</i>	<i>CMOS 1.8V</i>	<i>Asynchronous serial port data in</i>
<i>SER[0]_RTS#</i>	<i>Output</i>	<i>CMOS 1.8V</i>	<i>Request to Send handshake line for SER0</i>
<i>SER[0]_CTS#</i>	<i>Input</i>	<i>CMOS 1.8V</i>	<i>Clear to Send handshake line for SER0</i>
<i>SER[2]_RTS#</i>	<i>Output</i>	<i>CMOS 1.8V</i>	<i>Request to Send handshake line for SER2</i>
<i>SER[2]_CTS#</i>	<i>Input</i>	<i>CMOS 1.8V</i>	<i>Clear to Send handshake line for SER2</i>

2.1.16. I2C Interface

There is a minimum configuration of I2C ports up to a maximum of 5 ports defined in the SMARC specification: *PM* (Power Management), *LCD* (Liquid Crystal Display), *GP* (General Purpose), *CAM* (Camera) and *HDMI*. Because *SMARC-FiMX7* does not have *HDMI* interface, it defines four out of the five I2C buses and supports multiple masters and slaves in fast mode (400 KHz operation).

The *I2C_PM* is implemented directly from *Qualcomm/NXP i.MX7 I2C1* interfaces. The *I2C_HDMI* is not implemented. The *I2C_GP* is implemented directly from *Qualcomm/NXP i.MX7 I2C2* interfaces. The *I2C_LCD* is implemented directly from *Qualcomm/NXP i.MX7 I2C3* interfaces and *I2C_CAM* is implemented directly from *Qualcomm/NXP i.MX7 I2C4* interfaces.

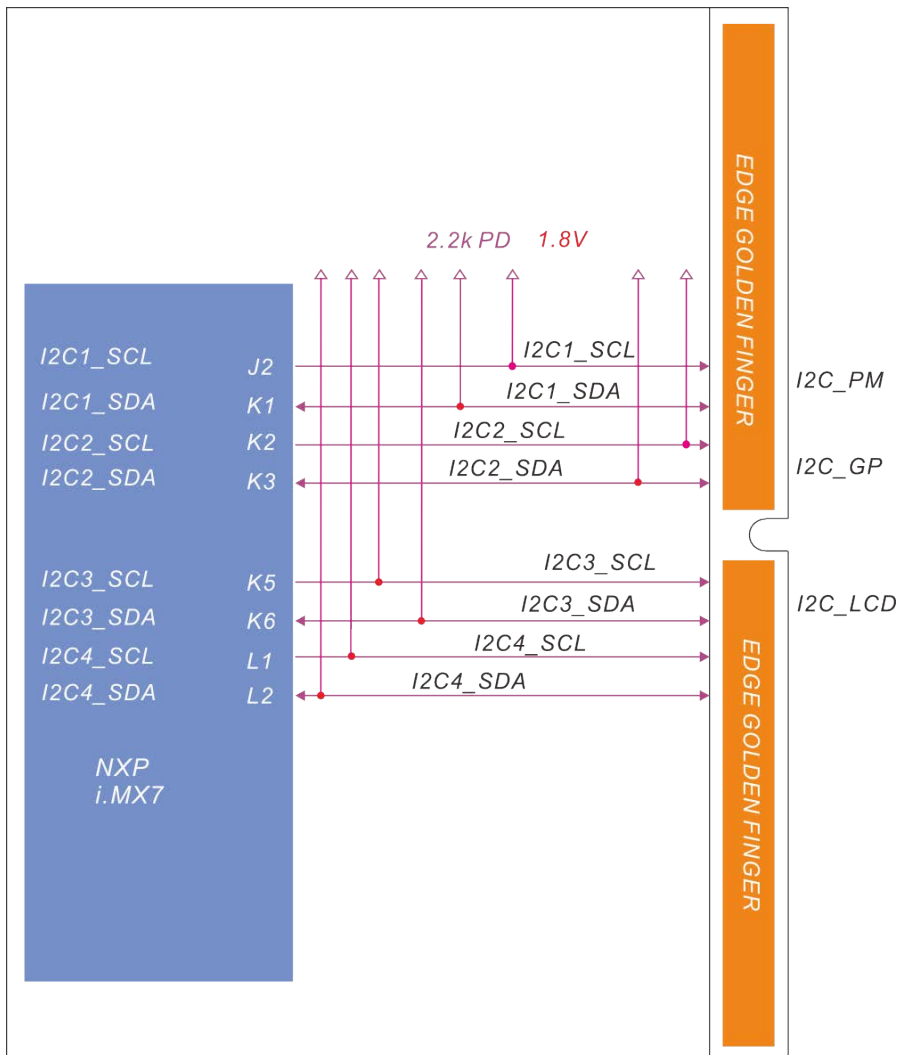

Figure 10. I2C Interface Block Diagram

Embedian, Inc.

This will be summarized below.

<i>I2C Port</i>		<i>Primary Purpose</i>	<i>Alternative Use</i>	<i>I/O Voltage Level</i>
<i>Golden Finger Connector</i>	<i>i.MX7 CPU</i>			
<i>I2C_PM</i>	<i>I2C1</i>	<i>Power Management support</i>	<i>System configuration management</i>	<i>CMOS 1.8V</i>
<i>I2C_GP</i>	<i>I2C2</i>	<i>General purpose use</i>		<i>CMOS 1.8V</i>
<i>I2C_LCD</i>	<i>I2C3</i>	<i>LCD display support, to read LCD display EDID EEPROMs (for parallel and LVDS LCD,)</i>	<i>General Purpose</i>	<i>CMOS 1.8V</i>
<i>I2C_CAM</i>	<i>I2C4</i>	<i>Serial camera</i>	<i>General Purpose</i>	<i>CMOS 1.8V</i>

Note:

The 2.2k pull-up resistors for *I2C_SCL* and *I2C_SDA* signals are on module.

Embedian, Inc.

The I2C interface signals are exposed on the SMARC golden finger edge connector as shown below:

Qualcomm/NXP i.MX7 CPU			SMARC-FiMX7 Edge Golden Finger		Net Names	Note
Ball	Mode	Pin Name	Pin#	Pin Name		
I2C_PM						
J2	ALT0	I2C1_SCL__ I2C1_SCL	P121	I2C_PM_CK	I2C_PM_CK	Power management I2C bus clock
K1	ALT0	I2C1_SDA__ I2C1_SDA	P122	I2C_PM_DAT	I2C_PM_SDA	Power management I2C bus data
I2C_GP						
K2	ALT0	I2C2_SCL__ I2C2_SCL	S48	I2C_GP_CK	I2C_GP_CK	General purpose I2C bus clock
K3	ALT0	I2C2_SDA__ I2C2_SDA	S49	I2C_GP_DAT	I2C_GP_DAT	General purpose I2C bus data
I2C_LCD						
K5	ALT0	I2C3_SCL__ I2C3_SCL	S139	I2C_LCD_CK	I2C_LCD_CK	LCD display I2C bus clock
K6	ATL0	I2C3_SDA__ I2C3_SDA	S140	I2C_LCD_DAT	I2C_LCD_DAT	LCD display I2C bus data
I2C_CAM						
L1	ALT0	I2C4_SCL__ I2C4_SCL	S1	I2C_CAM1_CK	I2C_CAM1_CK	Camera I2C bus clock
L2	ALT0	I2C4_SDA__ I2C4_SDA	S2	I2C_CAM1_DAT	I2C_CAM1_DAT	Camera I2C bus data

Embedian, Inc.

Note:

All I2C bus and are operated at 1.8V. The slave devices and their address details are listed in the following table:

#	Device	Description	Address (7-bit)	Address (8-bit)		Notes
				Read	Write	
I2C_PM (I2C1) Bus						
1	Pericom PI6CFG201BZDI E	PCIe Gen 1-2-3 Clock Generator	0x68	0xA1	0xA0	General purpose parameter EEPROM, Serial number, etc in PICMG EEPROM format
2	NXP MC32PF3000A1EP	PMIC	0x08			
3	Seiko S-35390A	Real-time clock IC	0x30	0x61	0x60	General purpose parameter with INT1 register access
I2C_GP						
1	On Semiconductor CAT24C32	EEPROM	0x50	0xA1	0xA0	General purpose parameter EEPROM, Serial number, etc in PICMG EEPROM format

Note:

On-module EEPROM has been moved from I2C_PM to I2C_GP at SMARC 2.0.

2.1.17. CAN Bus Interface

The Controller Area Network (CAN) is a serial communications protocol which efficiently supports distributed real-time control with a high level of security. The *SMARC-FiMX7* module supports two CAN bus interfaces.

CAN interface signals are exposed on the *SMARC* golden finger edge connector as shown below:

Qualcomm/NXP i.MX7 CPU			SMARC-FiMX7 Edge Golden Finger		Net Names	Note
Ball	Mode	Pin Name	Pin#	Pin Name		
CAN0 BUS						
T3	ALT3	GPI01_I013__ FLEXCAN1_TX	P143	CAN0_TX	CAN0_TX	CAN0 Transmit output
T2	ALT3	GPI01_I012__ FLEXCAN1_RX	P144	CAN0_RX	CAN0_RX	CAN0 Receive input
CAN1 BUS						
T6	ALT3	GPI01_I015__ FLEXCAN2_TX	P145	CAN1_TX	CAN1_TX	CAN1 Transmit output
T5	ALT3	GPI01_I014__ FLEXCAN2_RX	P146	CAN1_RX	CAN1_RX	CAN1 Receive input

By *SMARC* hardware specification, CAN0 bus error condition signaling should be supported on the Module *GPI08 (P116)* pin. This is an active low input to the Module from the CAN bus transceiver. CAN1 bus error condition signaling should be supported on the Module *GPI09 (P117)* pin. This is an active low input to the Module from the CAN bus transceiver

A CAN transceiver on carrier is necessary to adapt the signals from *SMARC* golden finger edge connector, which is TTL levels, to the physical layer used. Because the CAN bus system is typically used to connect multiple systems and is often run over very long distances, both power supply and signal path must be electrically isolated to meet a certain isolation level. Users can refer the “**SMARC Carrier Board Hardware Design Guide**” or CAN transceiver application note such as TI ISO1050 for more details.

2.1.17.1. CAN0 BUS Signals

<i>Edge Golden Finder Signal Name</i>	<i>Direction</i>	<i>Type Tolerance</i>	<i>Description</i>
CAN0_TX	<i>Output</i>	CMOS 1.8V	<i>CAN0 Transmit output</i>
CAN0_RX	<i>Input</i>	CMOS 1.8V	<i>CAN0 Receive input</i>

2.1.17.2. CAN1 BUS Signals

<i>Edge Golden Finder Signal Name</i>	<i>Direction</i>	<i>Type Tolerance</i>	<i>Description</i>
CAN1_TX	<i>Output</i>	CMOS 1.8V	<i>CAN1 Transmit output</i>
CAN1_RX	<i>Input</i>	CMOS 1.8V	<i>CAN1 Receive input</i>

2.1.18. GPIOs

The *SMARC-FiMX7* module supports 12 *GPIOs*, per the *SMARC* specification. Specific alternate functions are assigned to some *GPIOs* such as PWM / Tachometer capability, Camera support, *CAN* Error Signaling and HD Audio reset. All pins are capable of bi-directional operation. A default direction of operation is assigned, with half of them (*GPIO0* – *GPIO5*) for use as outputs and the remainder (*GPIO6* – *GPIO11*) as inputs by *SMARC* hardware specification.

Embedian, Inc.

GPIO signals are exposed on the SMARC golden finger edge connector as shown below:

Qualcomm/NXP i.MX7 CPU			SMARC-FiMX7 Edge Golden Finger		Net Names	Note
Ball	Mode	Pin Name	Pin#	Pin Name		
GPIOs						
P20	ALT5	EPDC_DATA00__ GPIO2_I000	P108	GPIO0/CAM0_PWR#	GPIO0	Camera 0 Power Enable, active low output
P21	ALT5	EPDC_DATA01__ GPIO2_I001	P109	GPIO1/CAM1_PWR#	GPIO1	Camera 1 Power Enable, active low output
N20	ALT5	EPDC_DATA02__ GPIO2_I002	P110	GPIO2/CAM0_RST#	GPIO2	Camera 0 Reset, active low output
N21	ALT5	EPDC_DATA03__ GPIO2_I003	P111	GPIO3/CAM1_RST#	GPIO3	Camera 1 Reset, active low output
N22	ALT5	EPDC_DATA04__ GPIO2_I004	P112	GPIO4/HDA_RST#	GPIO4	HD Audio Reset, active low output
N2	ALT1	GPIO1_I001__ PWM1	P113	GPIO5/PWM_OUT	GPIO5	PWM output
M20	ALT5	EPDC_DATA05__ GPIO2_I005	P114	GPIO6/TACHIN	GPIO6	Tachometer input (used with the GPIO5 PWM)
M22	ALT5	EPDC_DATA07__ GPIO2_I007	P115	GPIO7/PCAM_FLD	GPIO7	PCAM_FLD (Field) signal input
M21	ALT5	EPDC_DATA06__ GPIO2_I006	P116	GPIO8/CAN0_ERR#	GPIO8	CAN0 Error signal, active low input
L4	ALT5	UART1_TXD__ GPIO4_I001	P117	GPIO9/CAN1_ERR#	GPIO9	CAN1 Error signal, active low input
M5	ALT5	UART3_RTS__ GPIO4_I006	P118	GPIO10	GPIO10	
M6	ALT5	UART3_CTS__ GPIO4_I007	P119	GPIO11	GPIO11	

2.1.18.1. GPIO Signals

Twelve Module pins are allocated for GPIO (general purpose input / output) use. All pins are capable of bi-directional operation. By SMARC specification, *GPIO0* – *GPIO5* are recommended for use as outputs and the remainder (*GPIO6* – *GPIO11*) as inputs.

At Module power-up, the state of the GPIO pins may not be defined, and may briefly be configured in the “wrong” state, before boot loader code corrects them. Carrier designers should be aware of this and plan accordingly.

All GPIO pins are capable of generating interrupts. The interrupt characteristics (edge or level sensitivity, polarity) are generally configurable in the *i.MX7* register set.

<i>Edge Golden Finder Signal Name</i>	<i>Preferred Direction</i>	<i>Type Tolerance</i>	<i>Description</i>
<i>GPIO0/CAM0_PWR#</i>	<i>Output</i>	<i>CMOS 1.8V</i>	<i>Camera 0 Power Enable, active low output</i>
<i>GPIO1/CAM1_PWR#</i>	<i>Output</i>	<i>CMOS 1.8V</i>	<i>Camera 1 Power Enable, active low output</i>
<i>GPIO2/CAM0_RST#</i>	<i>Output</i>	<i>CMOS 1.8V</i>	<i>Camera 0 Reset, active low output</i>
<i>GPIO3/CAM1_RST#</i>	<i>Output</i>	<i>CMOS 1.8V</i>	<i>Camera 1 Reset, active low output</i>
<i>GPIO4/HDA_RST#</i>	<i>Output</i>	<i>CMOS 1.8V</i>	<i>HD Audio Reset, active low output</i>
<i>GPIO5/PWM_OUT</i>	<i>Output</i>	<i>CMOS 1.8V</i>	<i>PWM output</i>
<i>GPIO6/TACHIN</i>	<i>Input</i>	<i>CMOS 1.8V</i>	<i>Tachometer input (used with the GPIO5 PWM)</i>
<i>GPIO7/PCAM_FLD</i>	<i>Input</i>	<i>CMOS 1.8V</i>	<i>PCAM_FLD (Field) signal input</i>
<i>GPIO8/CAN0_ERR#</i>	<i>Input</i>	<i>CMOS 1.8V</i>	<i>CAN0 Error signal, active low input</i>
<i>GPIO9/CAN1_ERR#</i>	<i>Input</i>	<i>CMOS 1.8V</i>	<i>CAN1 Error signal, active low input</i>
<i>GPIO10</i>	<i>Input</i>	<i>CMOS 1.8V</i>	
<i>GPIO11</i>	<i>Input</i>	<i>CMOS 1.8V</i>	

2.1.19. Other Control Pins

SMARC specification defines some special control signals for power management. They are especially useful for mobile devices. The *SMARC-FiMX7* module supports all those signals.

The power management signals are exposed on the *SMARC* golden finger edge connector as shown below:

Qualcomm/NXP i.MX7 CPU			SMARC-FiMX7 Edge Golden Finger		Net Names	Note
Ball	Mode	Pin Name	Pin#	Pin Name		
<i>Special Control Pin</i>						
AC8		ONOFF	P128	POWER_BTN#	POWER_BTN#	Power-button input from Carrier board.
C3	ALT5	SD2_WP__ GPIO5_I010	S148	LID#	LID#	Lid open/close indication to Module. Low indicates lid closure.
E4	ALT5	SD2_DATA00__ GPIO5_I014	S149	SLEEP#	SLEEP#	Sleep indicator from Carrier board. May be sourced from user Sleep button or Carrier logic. Carrier to float the line in in-active state.
R1	ALT0	GPIO1_I008__ GPIO1_I008	S151	CHARGING#	CHARGING#	Held low by Carrier during battery charging.

Qualcomm/NXP i.MX7 CPU			SMARC-FiMX7 Edge Golden Finger		Net Names	Note
Ball	Mode	Pin Name	Pin#	Pin Name		
<i>Special Control Pin</i>						
R2	ALT0	GPI01_I009__ GPI01_I009	S152	CHARGER_ PRSNT#	CHARGER_ PRSNT#	Held low by Carrier if DC input for battery charger is present.
C12	ALT5	SAI1_RXFS__ GPIO6_I016	S153	CARRIER_STBY#	CARRIER_STBY#	The Module shall drive this signal low when the system is in a standby power state.
			S154	CARRIER_PWR_ON	CARRIER_PWR_ON	Carrier board circuits should not be powered up until the Module asserts the CARRIER_PWR_ON signal.
G3	ALT5	SD2_RESET__ GPIO5_I0011	S156	BATLOW#	BAT_LOW#	Battery low indication to Module.

2.1.19.1. Other Control Signals

Edge Golden Finder Signal Name	Preferred Direction	Type Tolerance	Description
<i>POWER_BTN#</i>	<i>Input</i>	CMOS 1.8V	<i>Power-button input from Carrier board.</i>
<i>LID#</i>	<i>Input</i>	CMOS 1.8V	<i>Lid open/close indication to Module. Low indicates lid closure.</i>
<i>SLEEP#</i>	<i>Input</i>	CMOS 1.8V	<i>Sleep indicator from Carrier board. May be sourced from user Sleep button or Carrier logic. Carrier to float the line in in-active state.</i>
<i>CHARGING#</i>	<i>Input</i>	CMOS 1.8V	<i>Held low by Carrier during battery charging.</i>
<i>CHARGER_PRSNT#</i>	<i>Input</i>	CMOS 1.8V	<i>Held low by Carrier if DC input for battery charger is present.</i>
<i>CARRIER_STBY#</i>	<i>Output</i>	CMOS 1.8V	<i>The Module shall drive this signal low when the system is in a standby power state.</i>
<i>CARRIER_PWR_ON</i>	<i>Output</i>	CMOS 1.8V	<i>Carrier board circuits should not be powered up until the Module asserts the CARRIER_PWR_ON signal.</i>
<i>BATLOW#</i>	<i>Input</i>	CMOS 1.8V	<i>Battery low indication to Module.</i>

2.1.20. Watchdog Timer Interface

i.MX7 features an internal WDT. Embedian’s Linux kernel enables the internal *i.MX7* WDT and makes this functionality available to users through the standard Linux Watchdog API.

A description of the API is available following the link below:

<http://www.kernel.org/doc/Documentation/watchdog/watchdog-api.txt>

WDT signals are exposed on the SMARC golden finger edge connector as shown below:

Qualcomm/NXP <i>i.MX7</i> CPU			SMARC-FiMX7 Edge Golden Finger		Net Names	Note
Ball	Mode	Pin Name	Pin#	Pin Name		
<i>Watchdog Timer</i>						
E19	ALT1	ENET1_CRSD0__ WDOG2_RST_B_DEB	S145	WDT_TIME_OUT#	WDT_TIME_OUT#	Watchdog-Timer Output

Note:

GPIO1_IO00__WDOG1_B signal connects *PWRON* of *MC32PF3000A1EP* PMIC on module.

2.1.21. JTAG

Figure 11 shows the *SMARC-FiMX7 JTAG* connectors location and pin out.

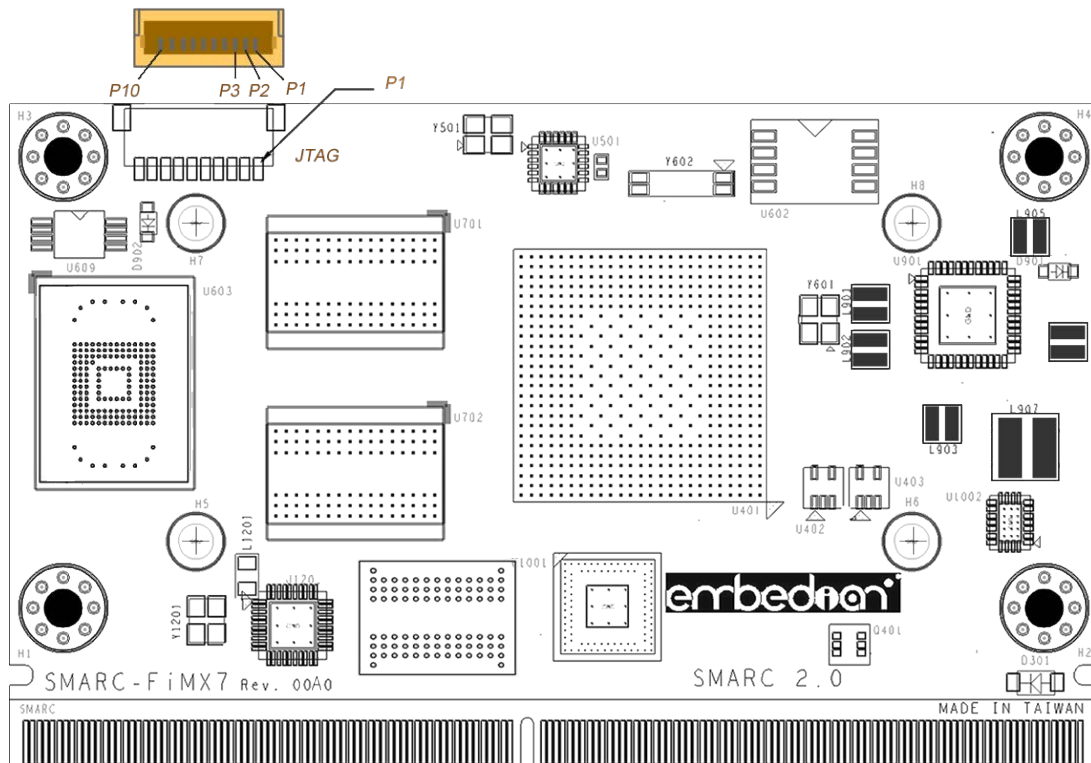

Figure 11: JTAG Connector Location and Pinout

JTAG functions for CPU debug and test are implemented on separate small form factor connector (CN3: *JST SM10B-SRSS-TB*, 1mm pitch R/A SMD Header). The *JTAG* pins are used to allow test equipment and circuit emulators to have access to the Module CPU. The pin-outs shown below are used:

Qualcomm/NXP i.MX7 CPU			JTAG(Connector: JST SM10B-SRSS-TB, 1mm pitch R/A SMD Header)		Type	Note
Ball	Mode	Pin Name	Pin#	Pin Name		
JTAG						
			1	VDD_18A	Power	JTAG I/O Voltage (sourced by Module)
U2	ATL0	JTAG_TRST_B	2	nTRST	I	JTAG Reset, active Low
U4	ALT0	JTAG_TMS	3	TMS	I	JTAG mode select
U6	ALT0	JTAG_TDO	4	TDO	O	JTAG data out
U3	ALT0	JTAG_TDI	5	TDI	I	JTAG data in
U5	ALT0	JTAG_TCK	6	TCK	I	JTAG clock
			7	RTCK	I	JTAG return clock
			8	GND	Ground	Ground
			9	MFG_Mode#	I	Pulled low to allow in-circuit SPI ROM update
			10	GND	Ground	Ground

2.1.22. Boot ID EEPROM

The SMARC-FiMX7 module includes an I2C serial EEPROM available on the I2C_PM bus. An On Semiconductor 24C32 or equivalent EEPROM is used in the module. The device operates at 1.8V. The Module serial EEPROM is placed at I2C slave addresses A2 A1 A0 set to 0 (I2C slave address 50 hex, 7 bit address format or A0 / A1 hex, 8 bit format) (for I2C EEPROMs, address bits A6 A5 A4 A3 are set to binary 0101 convention).

The module serial EEPROM is intended to retain module parameter information, including serial number. The module serial EEPROM data structure conforms to the PICMG® EEPROM Embedded EEPROM Specification.

Note:

Embedian, Inc.

The *EEPROM ID* memory layout is now follow the mainline and as follows.

Name	Size (Bytes)	Contents
Header	4	<i>MSB 0xEE3355AA LSB</i>
Board Name	8	<i>Name for Board in ASCII "SMCMX7D1" = Embedian SMARC-FiMX7 Computer on Module with Dual Core and 1GB DDR3L Configuration</i> <i>"SMCMX7S0" = Embedian SMARC-FiMX7 Computer on Module with solo Core and 512MB DDR3L Configuration</i>
Version	4	<i>Hardware version code for version in ASCII "00A0" = rev. A0</i>
Serial Number	12	<i>Serial number of the board. This is a 12 character string which is: WWYYMSD1nnnn</i> <i>Where: WW = 2 digit week of the year of production</i> <i>YY = 2 digit year of production</i> <i>MS = Module Serial Number</i> <i>D1/S0 = CPU Core and DDR Configuration Variants</i> <i>nnnn = incrementing board number</i>
Configuration Option	32	<i>Codes to show the configuration setup on this board. For the available module variants supported, the following codes are used:</i> <i>ASCII = "SMCMX7D1" = default configuration</i> <i>Remaining 24 bytes are reserved</i>
MAC Address	6	<i>Ethernet MAC Address (10:0D:32:XX:XX:XX)</i>
MAC Address	6	<i>Ethernet MAC Address for 2nd LAN (10:0D:32:XX:XX:XX)</i>
Available	32720	<i>Available space for other non-volatile codes/data</i>

2.2 SMARC-FiMX7 Debug

2.2.1. Serial Port Debug

SMARC module has 4 serial output ports, *SER0*, *SER1*, *SER2* and *SER3*. Out of these 4 serial ports, *SER3* is set as the serial debug port use for *i.MX7* from Embedian. Users can change to any port they want to. *SER3* is exposed (along with all other serial ports available on the module) in the *SMARC-FiMX7* Evaluation Carrier. The default baud rate setting is 115,200 8N1.

SER3 pin out of the *SMARC-FiMX7* is shown below:

Qualcomm/NXP i.MX7 CPU		SMARC-FiMX7 Edge Golden Finger		Net Names	Notes
mode	Pin Name	Pin#	Pin Name		
<i>SER3 (Debugging Port)</i>					
ALTO	UART3_TX_DATA_	P140	SER3_TX	SER3_TX	Asynchronous serial port data out
	$\bar{\text{UART3_TX_DATA}}$				
ALTO	UART3_RX_DATA_	P141	SER3_RX	SER3_RX	Asynchronous serial port data in
	$\bar{\text{UART3_RX_DATA}}$				

2.3 Mechanical Specifications

2.3.1. Module Dimensions

The *SMARC-FiMX7* complies with *SMARC* Hardware Specification in an 82mm x 50 mm form factor.

2.3.2. Height on Top

2.9mm maximum (without PCB) complied with *SMARC* specification defines as 3mm as the maximum.

2.3.3. Height on Bottom

0.9mm maximum (without PCB) complied with *SMARC* specification defines as 1.3mm as the maximum.

2.3.4. Mechanical Drawings

The mechanical information is shown in Figure 12: *SMARC-FiMX7* Mechanical Drawings (Top View) and Figure 13: *SMARC-FiMX7* Mechanical Drawings (Bottom View)

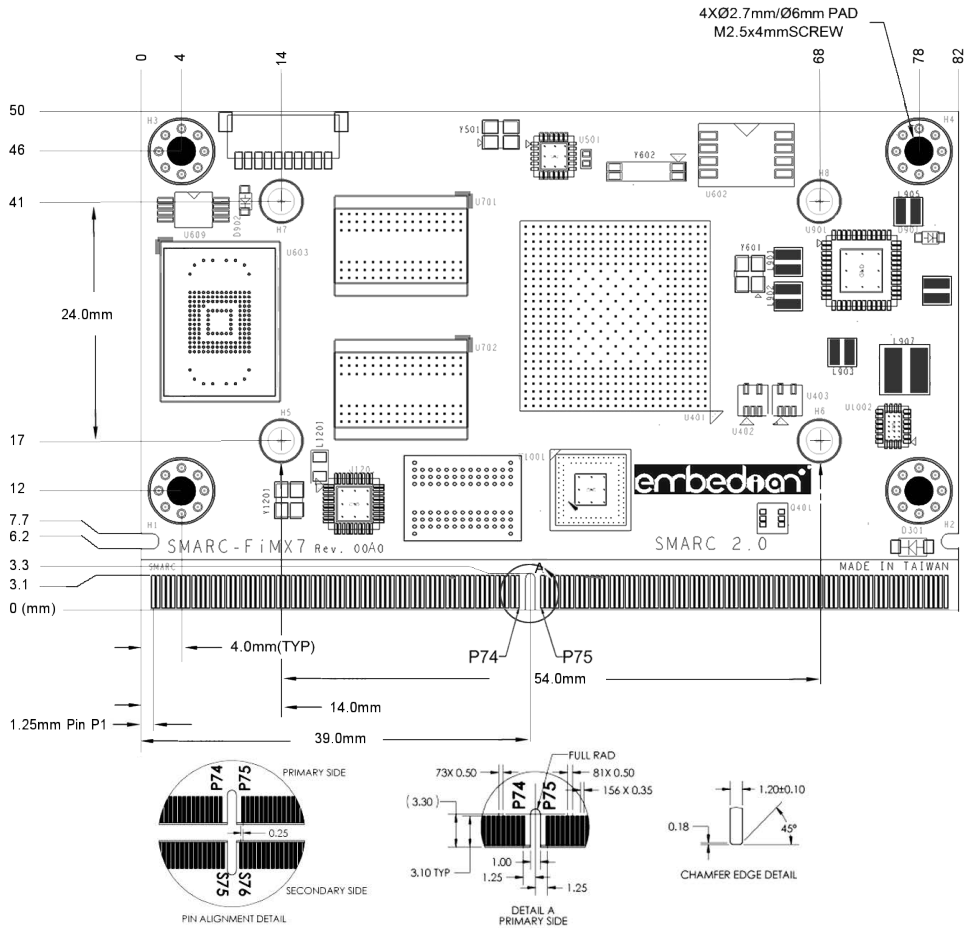

Figure 12. *SMARC-FiMX7* Mechanical Drawings (Top View)

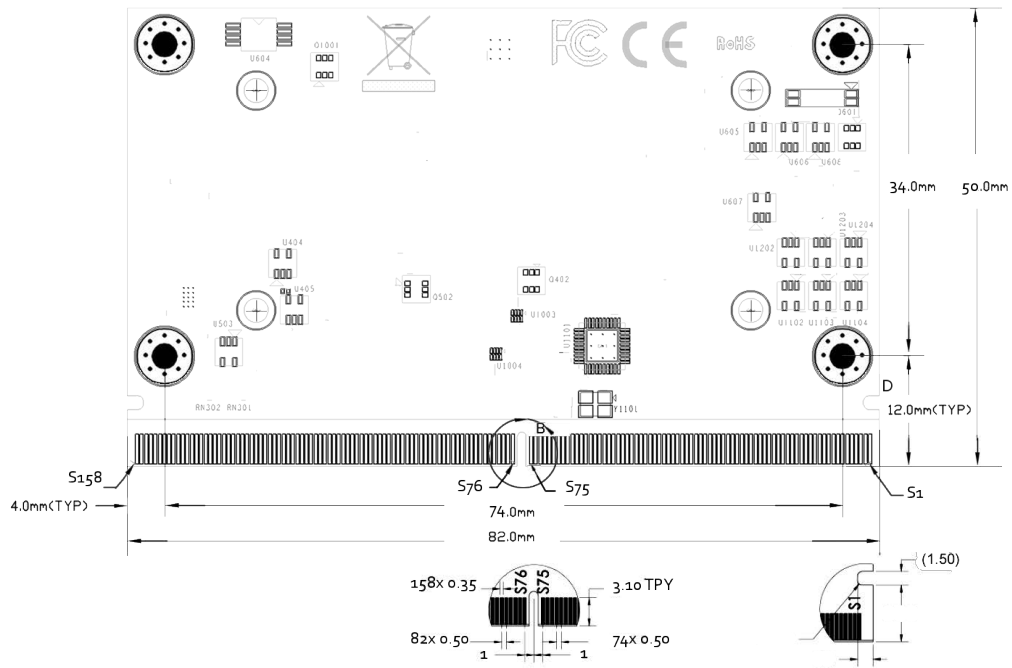

Figure 13. SMARC-FiMX7 Mechanical Drawings (Bottom View)

The figure on the following page details the 82mm x 50mm Module mechanical attributes, including the pin numbering and edge finger pattern.

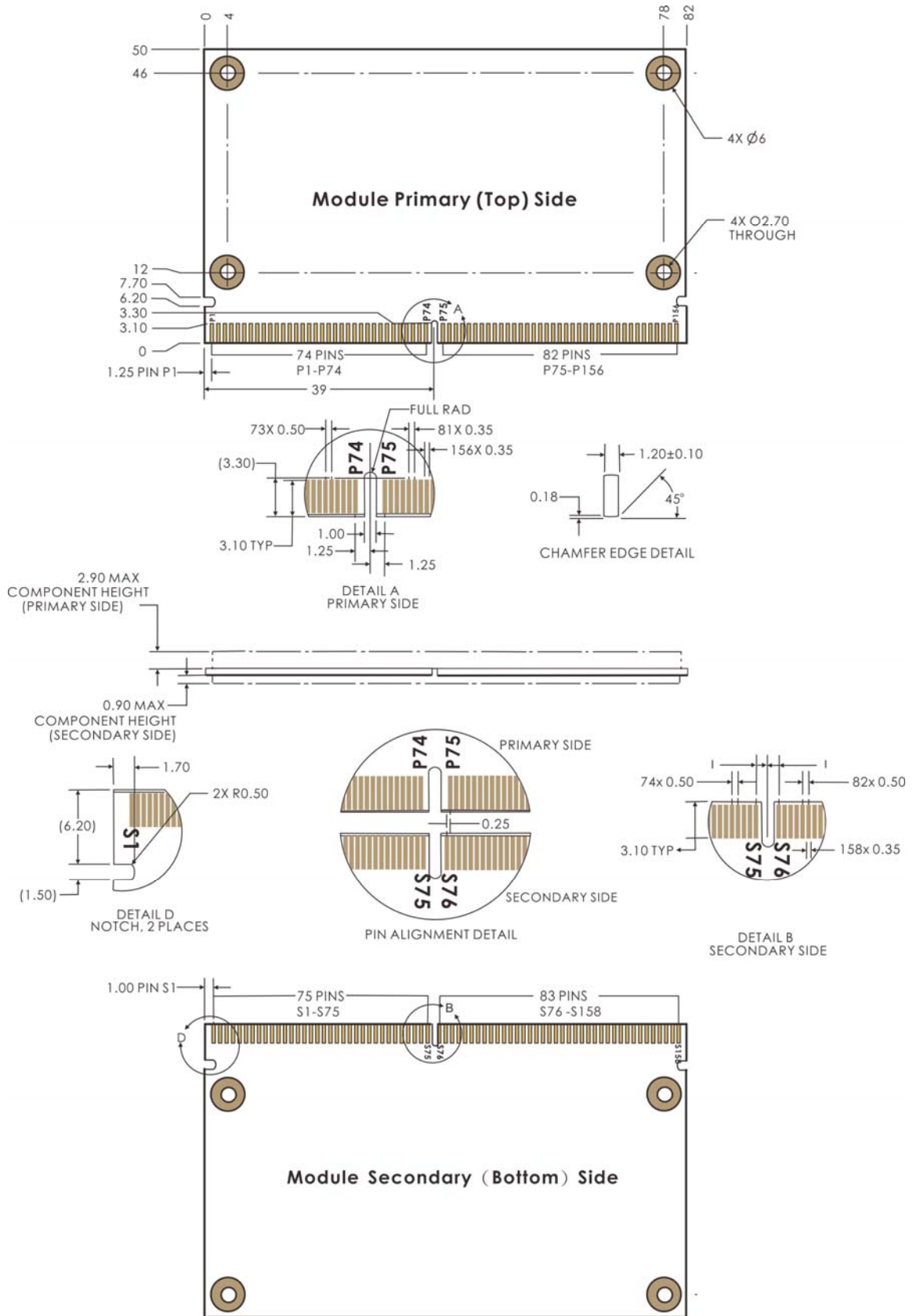

Figure 14: SMARC-FiMX7 Module Mechanical Outline

Top side major component (IC and Connector) information is shown in Figure 15: SMARC-FiMX7 Top side components.

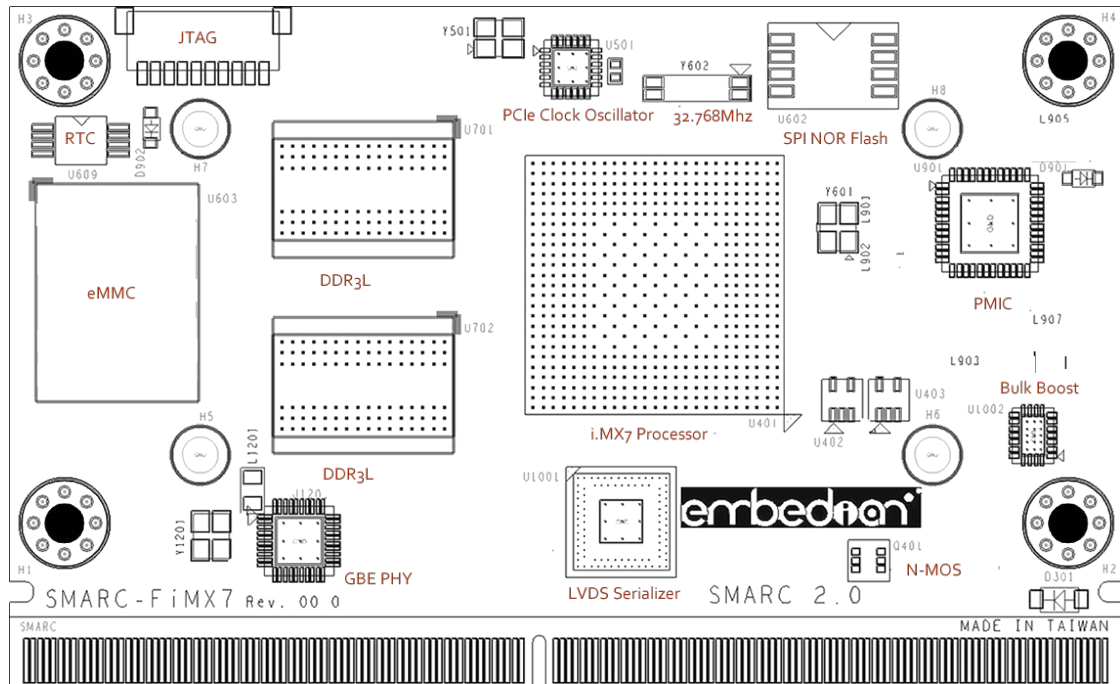

Figure 15. SMARC-FiMX7 Top Side Components

Bottom side major component (IC and Connector) information is shown in Figure 16: *SMARC-FiMX7* Bottom side components.

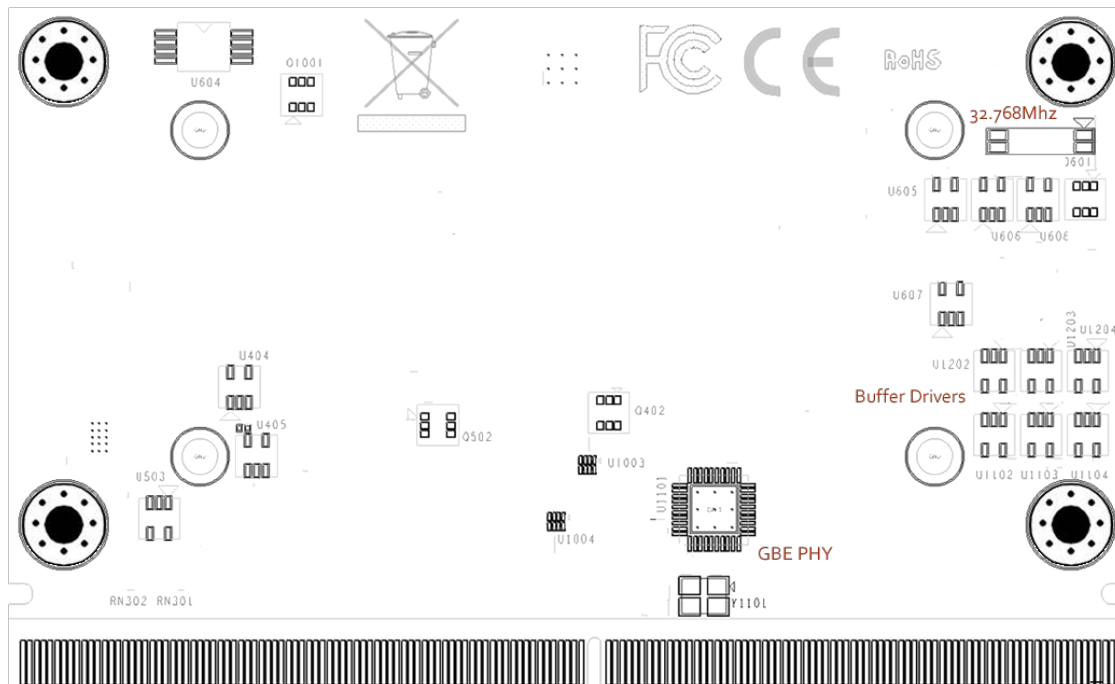

Figure 16. *SMARC-FiMX7* Bottom Side Components

SMARC-FiMX7 height information from Carrier board Top side to tallest Module component is shown in Figure 17: SMARC-FiMX7 Minimum “Z” Height:

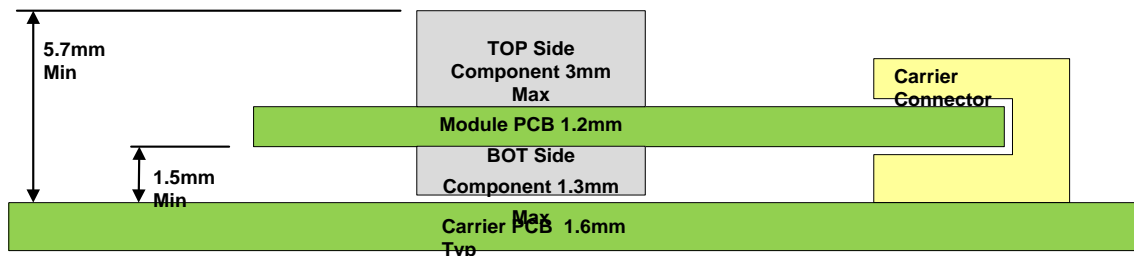

Figure 17. SMARC-FiMX7 Minimum “Z” Height

The SMARC connector board-to-board stack heights that are available may result in the use of non-standard spacer lengths. The board-to-board stack heights available include 1.5mm, 2.7mm and 5mm. Of these three, only the spacer for the 5mm stack would likely be a standard length.

When a 1.5mm stack height Carrier board connector is used, there shall not be components on the Carrier board Top side in the Module region. Additionally, when 1.5mm stack height connectors are used, there should not be PCB traces on the Carrier top side in the Module shadow. This is to prevent possible problems with metallic Module heat sink attachment hardware that may protrude through the Module.

If Carrier board components are required in this region, then the Carrier components must be on the Carrier Bottom side, or a taller Module-to-Carrier connector may be used. Stack heights of 2.7mm, 3mm, 5mm and up are available.

2.3.5. Carrier Board Connector PCB Footprint

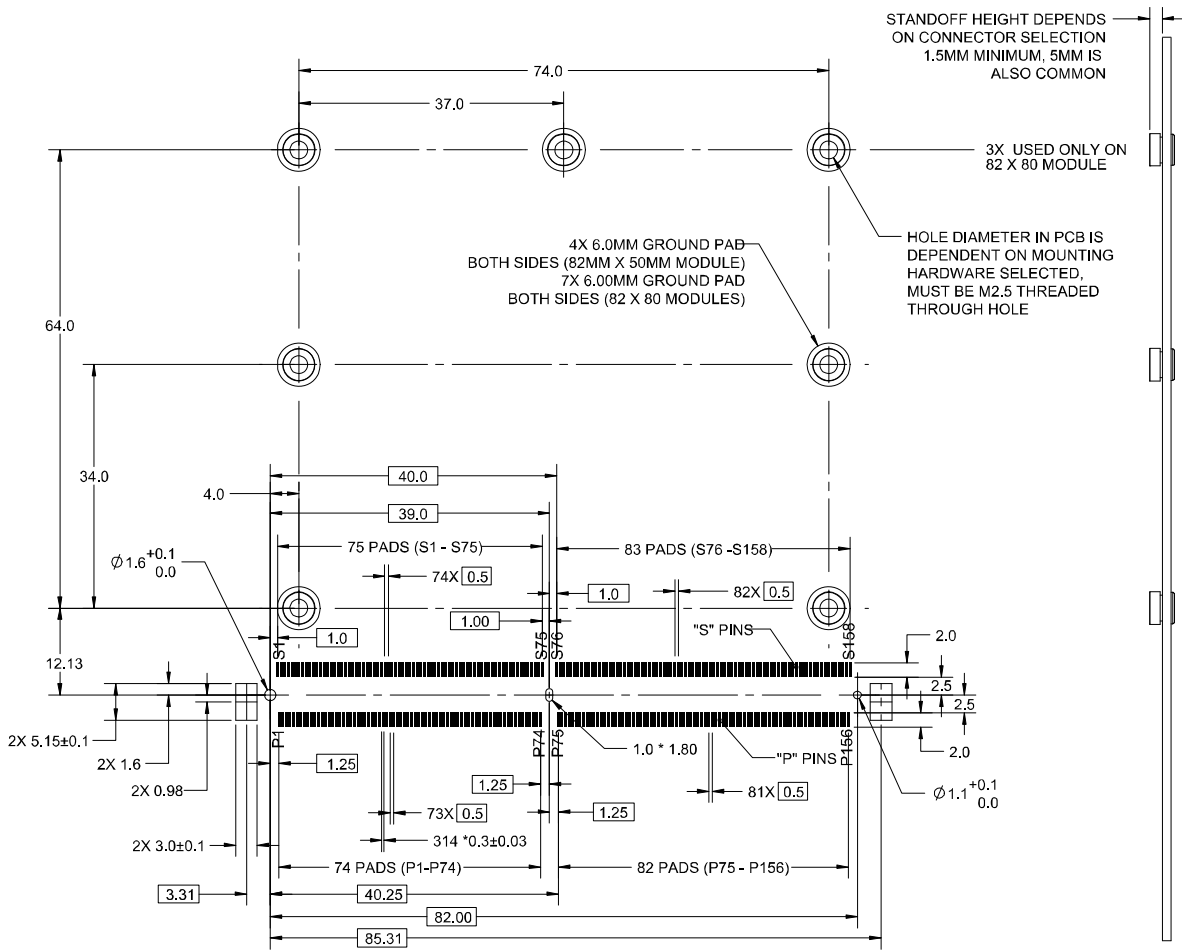

Figure 18: Carrier Board Connector PCB Footprint

Note:

The hole diameter for the 4 holes (82mm x 50mm Module) or 7 holes (82mm x 80mm Module) depends on the spacer hardware selection. See the section below for more information on this.

2.3.6. Module Assembly Hardware

The *SMARC-FiMX7* module is attached to the carrier with four M2.5 screws. A 4mm length screw is usually used. The attachment holes are located on the corners of the module. Attachment holes have a 6mm diameter pad, 2.7

mm dia drill hole as shown Figure 12: *SMARC-FiMX7* Mechanical Drawings (Top View)

2.3.7. Carrier Board Standoffs

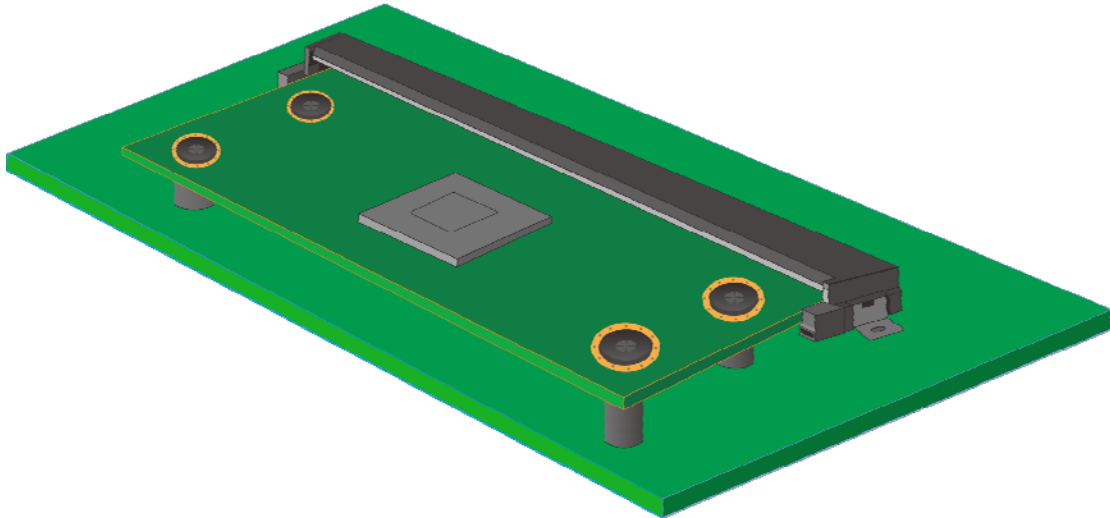

Figure 19: Screw Fixation

Standoffs secured to the Carrier board are expected. The standoffs are to be used with M2.5 hardware. Most implementations will use Carrier board standoffs that have M2.5 threads (as opposed to clearance holes). A short M2.5 screw and washer, inserted from the Module top side, secures the Module to the Carrier board threaded standoff.

The *SMARC* connector board-to-board stack heights that are available may result in the use of non-standard spacer lengths. The board-to-board stack heights available include 1.5mm, 2.7mm and 5mm. Of these three, only the spacer for the 5mm stack would likely be a standard length.

Penn Engineering and Manufacturing (PEM) (www.pemnet.com) makes surface mount spacers with M2.5 internal threads. The product line is called SMTSO (“surface mount technology stand offs”). The shortest standard length offered is 2mm. A custom part with 1.5mm standoff length, M2.5 internal thread, and 5.56mm standoff OD is available from PEM. The Carrier PCB requires a 4.22mm hole and 6.2mm pad to accept these parts.

Other vendors such as RAF Electronic Hardware (www.rafhdwe.com) offer M2.5 compatible swaged standoffs. Swaged standoffs require the use of a press and anvil at the CM. Their use is common in the industry. The standoff OD and Carrier PCB hole size requirements are different from the PEM SMTSO standoffs described above.

2.3.8. Carrier Connector

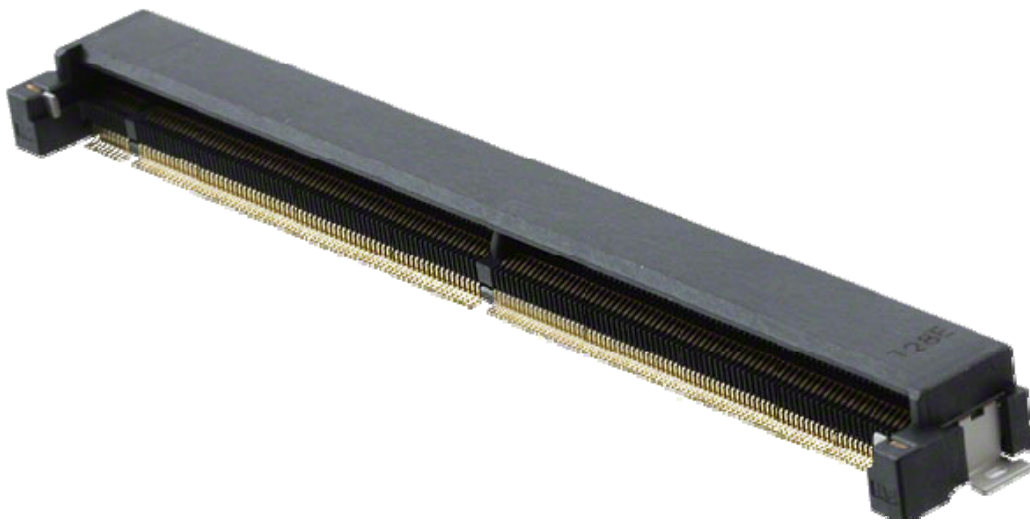

Figure 20: MXM3 Carrier Connector

Embedian, Inc.

The Carrier board connector is a 314 pin 0.5mm pitch right angle part designed for use with 1.2mm thick mating PCBs with the appropriate edge finger pattern. The connector is commonly used for MXM3 graphics cards. The SMARC Module uses the connector in a way quite different from the MXM3 usage.

<i>Vender</i>	<i>Vendor P/N</i>	<i>Stack Height</i>	<i>Body Height</i>	<i>Contact Plating</i>	<i>Pin Style</i>	<i>Body Color</i>
<i>Foxconn</i>	<i>AS0B821-S43B - *H</i>	<i>1.5mm</i>	<i>4.3mm</i>	<i>Flash</i>	<i>Std</i>	<i>Black</i>
<i>Foxconn</i>	<i>AS0B821-S43N - *H</i>	<i>1.5mm</i>	<i>4.3mm</i>	<i>Flash</i>	<i>Std</i>	<i>Ivory</i>
<i>Foxconn</i>	<i>AS0B826-S43B - *H</i>	<i>1.5mm</i>	<i>4.3mm</i>	<i>10 u-in</i>	<i>Std</i>	<i>Black</i>
<i>Foxconn</i>	<i>AS0B826-S43N - *H</i>	<i>1.5mm</i>	<i>4.3mm</i>	<i>10 u-in</i>	<i>Std</i>	<i>Ivory</i>
<i>Lotes</i>	<i>AAA-MXM-008-P04_A</i>	<i>1.5mm</i>	<i>4.3mm</i>	<i>Flash</i>	<i>Std</i>	<i>Tan</i>
<i>Lotes</i>	<i>AAA-MXM-008-P03</i>	<i>1.5mm</i>	<i>4.3mm</i>	<i>15 u-in</i>	<i>Std</i>	<i>Tan</i>
<i>Speedtech</i>	<i>B35P101-02111-H</i>	<i>1.56mm</i>	<i>4.0mm</i>	<i>Flash</i>	<i>Std</i>	<i>Black</i>
<i>Speedtech</i>	<i>B35P101-02011-H</i>	<i>1.56mm</i>	<i>4.0mm</i>	<i>Flash</i>	<i>Std</i>	<i>Tan</i>
<i>Speedtech</i>	<i>B35P101-02112-H</i>	<i>1.56mm</i>	<i>4.0mm</i>	<i>10 u-in</i>	<i>Std</i>	<i>Black</i>
<i>Speedtech</i>	<i>B35P101-02012-H</i>	<i>1.56mm</i>	<i>4.0mm</i>	<i>10 u-in</i>	<i>Std</i>	<i>Tan</i>
<i>Speedtech</i>	<i>B35P101-02113-H</i>	<i>1.56mm</i>	<i>4.0mm</i>	<i>15 u-in</i>	<i>Std</i>	<i>Black</i>
<i>Speedtech</i>	<i>B35P101-02013-H</i>	<i>1.56mm</i>	<i>4.0mm</i>	<i>15 u-in</i>	<i>Std</i>	<i>Tan</i>
<i>Aces</i>	<i>91781-314 2 8-001</i>	<i>2.7mm</i>	<i>5.2mm</i>	<i>3 u-in</i>	<i>Std</i>	<i>Black</i>

<i>Vender</i>	<i>Vendor P/N</i>	<i>Stack Height</i>	<i>Body Height</i>	<i>Contact Plating</i>	<i>Pin Style</i>	<i>Body Color</i>
<i>Foxconn</i>	<i>AS0B821-S55B - *H</i>	<i>2.7mm</i>	<i>5.5mm</i>	<i>Flash</i>	<i>Std</i>	<i>Black</i>
<i>Foxconn</i>	<i>AS0B821-S55N - *H</i>	<i>2.7mm</i>	<i>5.5mm</i>	<i>Flash</i>	<i>Std</i>	<i>Ivory</i>
<i>Foxconn</i>	<i>AS0B826-S55B - *H</i>	<i>2.7mm</i>	<i>5.5mm</i>	<i>10 u-in</i>	<i>Std</i>	<i>Black</i>
<i>Foxconn</i>	<i>AS0B826-S55N - *H</i>	<i>2.7mm</i>	<i>5.5mm</i>	<i>10 u-in</i>	<i>Std</i>	<i>Ivory</i>
<i>Speedtech</i>	<i>B35P101-02121-H</i>	<i>2.76mm</i>	<i>5.2mm</i>	<i>Flash</i>	<i>Std</i>	<i>Black</i>
<i>Speedtech</i>	<i>B35P101-02021-H</i>	<i>2.76mm</i>	<i>5.2mm</i>	<i>Flash</i>	<i>Std</i>	<i>Tan</i>
<i>Speedtech</i>	<i>B35P101-02122-H</i>	<i>2.76mm</i>	<i>5.2mm</i>	<i>10 u-in</i>	<i>Std</i>	<i>Black</i>
<i>Speedtech</i>	<i>B35P101-02022-H</i>	<i>2.76mm</i>	<i>5.2mm</i>	<i>10 u-in</i>	<i>Std</i>	<i>Tan</i>
<i>Speedtech</i>	<i>B35P101-02123-H</i>	<i>2.76mm</i>	<i>5.2mm</i>	<i>15 u-in</i>	<i>Std</i>	<i>Black</i>
<i>Speedtech</i>	<i>B35P101-02023-H</i>	<i>2.76mm</i>	<i>5.2mm</i>	<i>15 u-in</i>	<i>Std</i>	<i>Tan</i>
<i>Foxconn</i>	<i>AS0B821-S78B - *H</i>	<i>5.0mm</i>	<i>7.8mm</i>	<i>Flash</i>	<i>Std</i>	<i>Black</i>
<i>Foxconn</i>	<i>AS0B821-S78N - *H</i>	<i>5.0mm</i>	<i>7.8mm</i>	<i>Flash</i>	<i>Std</i>	<i>Ivory</i>
<i>Foxconn</i>	<i>AS0B826-S78B - *H</i>	<i>5.0mm</i>	<i>7.8mm</i>	<i>10 u-in</i>	<i>Std</i>	<i>Black</i>
<i>Foxconn</i>	<i>AS0B826-S78N - *H</i>	<i>5.0mm</i>	<i>7.8mm</i>	<i>10 u-in</i>	<i>Std</i>	<i>Ivory</i>
<i>Yamaichi⁽¹⁾</i>	<i>CN113-314-2001</i>	<i>5.0mm</i>	<i>7.8mm</i>	<i>0.3 u-meter</i>	<i>Std</i>	<i>Black</i>

Other, taller stack heights may be available from these and other vendors. Stack heights as tall as 11mm are shown on the Aces web site.

Note:

1. *Yamaichi CN113-314-2001* is automotive grade.
2. The vendor drawings for the connectors listed above show a PCB footprint pattern for use with an MXM3 graphics card. This footprint, and the associated pin numbering, is not suitable for SMARC use. The

MXM3 standard gangs large groups of pins together to provide ~80W capable power paths needed for X86 graphics cards. The *SMARC* module “ungangs” these pins to allow more signal pins. Footprint and pin numbering information for application of this 314 pin connector to *SMARC* is given in the sections below.

2.3.9. Module Cooling Solution—Heat Spreader

A standard heat-spreader plate for use with the *SMARC* 82mm x 50mm form factor is described below. A standard heat spreader plate definition allows the customer to use a Module from multiple vendors.

The heat spreader plate is sized at 82mm x 42mm x 3mm, and sits 3mm above the *SMARC* Module. The heat spreader plate ‘Y’ dimension is deliberately set at 42mm and not 50mm, to allow the plate to clear the *SMARC* MXM3 connector. The plate is shown in the figures below.

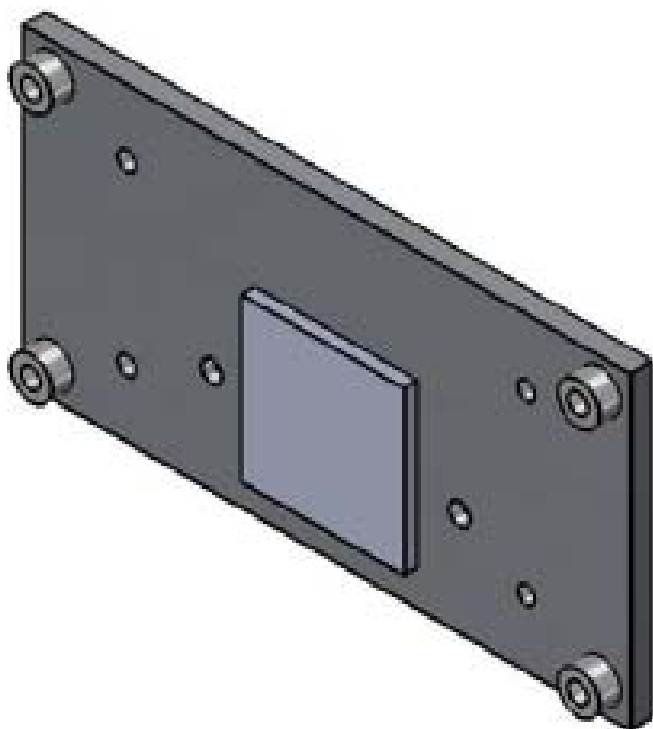

Figure 21: Heat Spreader

Embedian, Inc.

The internal square in the figure above is a thermally conductive and mechanically compliant Thermal Interface Material (or “TIM”). The exact X-Y position and Z thickness details of the TIM vary from design to design.

The two holes immediately adjacent to the TIM serve to secure the PCB in the SOC area and compress the TIM.

The four interior holes that are further from the center allow a heat sink to be attached to the heat spreader plate, or they can be used to secure the heat spreader plate to a chassis wall that serves as a heat sink.

Dimensions and further details may be found in the following figure.

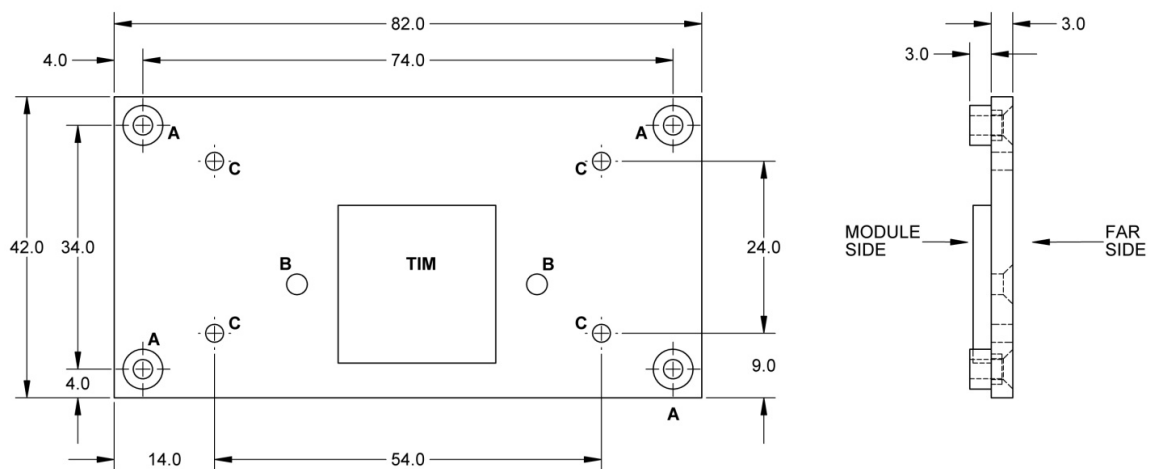

Dimensions in the figure above are in millimeters. “TIM” stands for “Thermal Interface Material”. The TIM takes up the small gap between the SOC top and the Module - facing side of the heat spreader.

Hole Reference	Description	Size
A	<p>SMARC Module corner mounting holes Spacing determined by SMARC specification for 82mm x 50mm Modules.</p> <p>Typically these holes have 3mm length press fit or swaged clearance standoffs on the Module side.</p> <p>These holes are typically countersunk on the far side of the plate, to allow the heat spreader plate to be flush with a secondary heat sink.</p>	<p>Hole size depends on standoffs used. Standoff diameter must be compatible with SMARC Module mounting hole pad and hole size (6.0mm pads, 2.7mm holes on the Module). The holes and standoffs are for use with M2.5 screw hardware.</p> <p>The far side of these holes are counter-sunk to allow the attachment screw to be flush with the far side heat spreader surface.</p>
B	Not Defined	
C	<p>Fixed location holes to allow the attachment of a heat sink to the heat spreader, or to allow the heat spreader to be secured to a chassis wall that can serve as a heat sink.</p>	M3 threaded holes

2.4 Electrical Specifications

2.4.1. Supply Voltage

The *SMARC-FiMX7* module operates over an input voltage range of 3.0V to 5.25V. Power is provided from the carrier through 10 power pins as defined by the *SMARC* specification.

Caution! A single 5V DC input is recommended.

2.4.2. RTC/Backup Voltage

3.0V RTC backup power is provided through the VDD_RTC pin from the carrier board. This connection provides back up power to the module PMIC. The RTC is powered via the primary system 3.3V supply during normal operation and via the VBAT power input, if it is present, during power-off.

2.4.3. No Separate Standby Voltage

The *SMARC-FiMX7* does not have a standby power rail. Standby operation is powered through the main supply voltage rail, as defined in the *SMARC* specification.

2.4.4. Module I/O Voltage

The *SMARC-FiMX7* module supports 1.8V (*SMARC* v2.0 compliant) level I/O voltage depending on the part number that users selected.

2.4.5. MTBF

The *SMARC-FiMX7* System MTBF (hours) : >100,000 hours

The above MTBF (Mean Time Between Failure) values were calculated using a combination of manufacturer's test data, if the data was available, and a Bellcore calculation for the remaining parts. The Bellcore calculation used is "Method 1 Case 1". In that particular method the components are assumed to be operating at a 50 % stress level in a 40° C ambient environment and the system is assumed to have not been burned in. Manufacturer's data has been used wherever possible. The manufacturer's data, when used, is specified at 50°C, so in that sense the following results are slightly conservative. The MTBF values shown below are for a 40°C in an office or telecommunications environment. Higher temperatures and other environmental stresses (extreme altitude, vibration, salt water exposure, etc.) lower MTBF values.

2.4.6. Power Consumption

The power consumption values listed in this document were measured under a controlled environment. The hardware used for testing includes an *SMARC-FiMX7* module, carrier board for *SMARC* ARM, TFT monitor, micro-SD card and USB keyboard. The carrier board was powered externally by a power supply unit so that it does not influence the power consumption value that is measured for the module. The USB keyboard was detached once the module was configured within the OS. All recorded values were averaged over a 30 second time period. The modules were cooled by the heatspreader specific to the module variants.

Each module was measured while running 32 bit Linaro Ubuntu 14.04. To measure the worst case power consumption, the cooling solution was removed and the CPU core temperature was allowed to run between 95° and 100°C at 100% workload. The peak current value was then recorded. This value should be taken into consideration when designing the system's power supply to ensure that the power supply is sufficient during worst case scenarios.

Power consumption values were recorded during the following stages:
Linaro Ubuntu 14.04 (32 bit)

- Desktop Idle
- 100% CPU workload
- 100% CPU workload at approximately 100°C peak power consumption

Note: With the linux stress tool, we stressed the CPU to maximum frequency.

Embedian, Inc.

The table below provides additional information about the different variants offered by the *SMARC-FiMX7*.

2.4.6.1. Qualcomm/NXP i.MX7 Cortex A7 800MHz Solo Core 512KB

L2 Cache

With 8GB onboard eMMC.

<i>P/N: SMARC-FiMX7-S</i>	<i>Qualcomm/NXP i.MX7 Cortex A7 800MHz Solo Core 512KB L2 Cache</i>		
<i>Memory Size</i>	<i>512MB</i>		
<i>Operating System</i>	<i>Ubuntu 14.04</i>		
<i>Power States</i>	<i>Desktop Idle</i>	<i>100% workload</i>	<i>Max. power consumption</i>
<i>Power Consumption (Amp/Watts)</i>	<i>0.15A/0.74W</i>	<i>0.18A/0.9W</i>	<i>0.29A/1.45W</i>

2.4.6.2. Qualcomm/NXP i.MX7 Cortex A7 1.2GHz Dual Core 512KB

L2 Cache

With 8GB onboard eMMC.

<i>P/N: SMARC-FiMX7-U</i>	<i>Qualcomm/NXP i.MX7 Cortex A7 1.2GHz Dual Lite Core 512KB L2 Cache</i>		
<i>Memory Size</i>	<i>1GB</i>		
<i>Operating System</i>	<i>Ubuntu 14.04</i>		
<i>Power States</i>	<i>Desktop Idle</i>	<i>100% workload</i>	<i>Max. power consumption</i>
<i>Power Consumption (Amp/Watts)</i>	<i>0.16A/0.8W</i>	<i>0.22A/1.1W</i>	<i>0.44A/2.2W</i>

2.5 Environmental Specifications

2.5.1. Operating Temperature

The *SMARC-FiMX7* module operates from -20°C to 85°C air temperature (so-called “extended temperature”), without a passive heat sink arrangement.

2.5.2. Humidity

Operating: 10% to 90% *RH* (non-condensing).
Non-operating: 5% to 95% *RH* (non-condensing).

2.5.3. ROHS/REACH Compliance

The *SMARC-FiMX7* module is compliant to the 2002/95/EC *RoHS* directive and *REACH* directive.

Chapter 3

Connector PinOut

This Chapter gives detail pinout of *SMARC-FiMX7* golden finger edge connector.

Section include :

- *SMARC-FiMX7* Connector Pin Mapping

Chapter 3 Connector Pinout

The Module pins are designated as *P1 – P156* on the Module Primary (Top) side, and *S1 – S158* on the Module Secondary (Bottom) side. There are total of 314 pins on the Module. The connector is sometimes identified as a 321 pin connector, but 7 pins are lost to the key (4 on the primary side and 3 on secondary side).

The Secondary (Bottom) side faces the Carrier board when a normal or standard Carrier connector is used.

The *SMARC-FiMX7* module pins are deliberately numbered as *P1 – P156* and *S1 – S158* for clarity and to differentiate the *SMARC* Module from *MXM3* graphics modules, which use the same connector but use the pins for very different functions. *MXM3* cards and *MXM3* baseboard connectors use different pin numbering scheme.

3.1 SMARC-FiMX7 Connector Pin Mapping

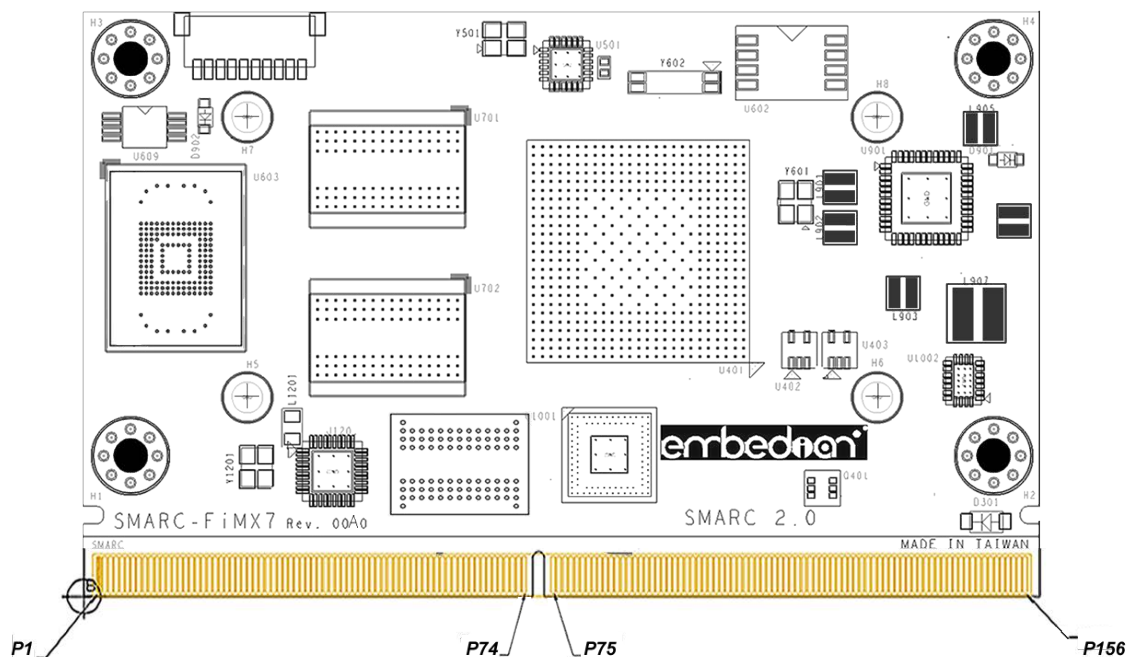

Figure 22: SMARC-FiMX7 edge finger primary pins

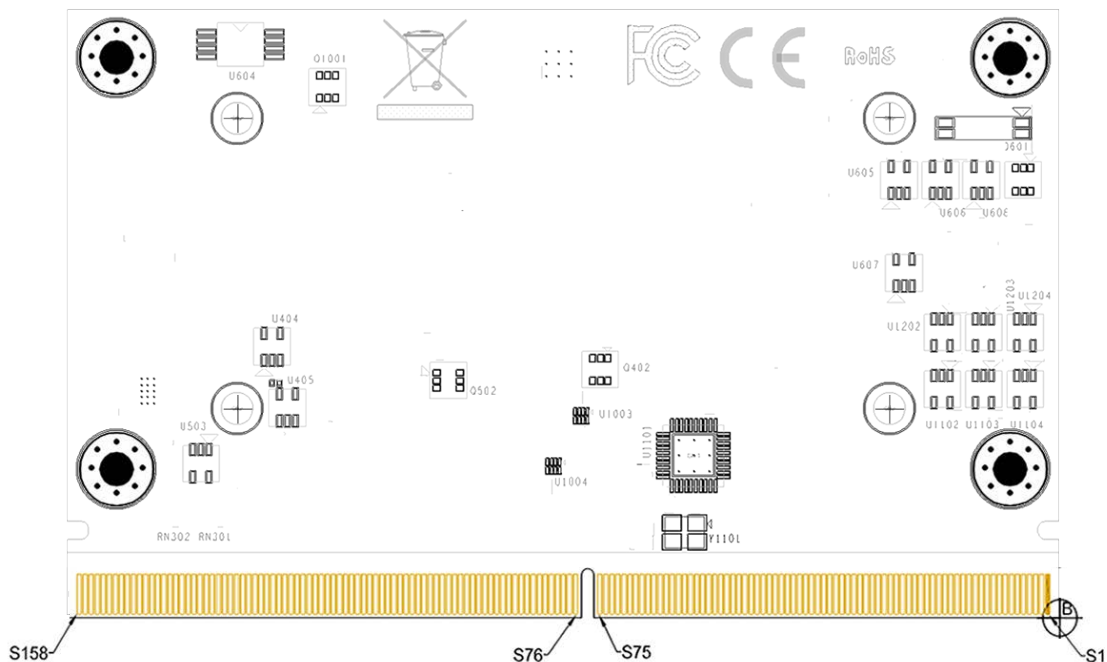

Figure 23: SMARC-FiMX7 edge finger secondary pins

The next tables describe each pin, its properties, and its use on the module and development board.

The “SMARC Edge Finger” column shows the connection of the signals defined in the SMARC specification. The “Qualcomm/NXP i.MX7 CPU” column shows the connection of the CPU signals on the module. The format of this column is “Ball/Mode/Signal Name” where “Signal Name” is the chip where the signals are connected, and “Ball” is the name of the pad where the signals are connected as they are defined in the i.MX7 processor datasheet. The grey text stands for the pins are not connected from SMARC-FiMX7 module.

Pinout Legend

- I** *Input*
- O** *Output*
- I/O** *Input or output*
- P** *Power*
- AI** *Analogue input*
- AO** *Analogue output*
- AIO** *Analogue Input or analogue output*
- OD** *Open Drain Signal*
- #** *Low level active signal*

SMARC Edge Finger		Qualcomm/NXP i.MX7 CPU			Type	Description
Pin#	Pin Name	Ball	Mode	Signal Name		
P1	SMB_ALERT_1V8#					Not used
P2	GND				P	Ground
P3	CSI1_CK+	B15		MIPI_CSI_CLK_P	I	CSI1 differential clock inputs
P4	CSI1_CK-	A15		MIPI_CSI_CLK_N	I	CSI1 differential clock inputs
P5	GBE1_SDP					Not used
P6	GBE0_SDP					Not used
P7	CSI1_RX0+	B16		MIPI_CSI_D0_P	I	CSI1 differential data inputs 0
P8	CSI1_RX0-	A16		MIPI_CSI_D0_N	I	CSI1 differential data input 0
P9	GND				P	Ground
P10	CSI1_RX1+	B14		MIPI_CSI_D1_P	I	CSI1 differential data input 1
P11	CSI1_RX1-	A14		MIPI_CSI_D1_N	I	CSI1 differential data inputs 1
P12	GND				P	Ground
P13	CSI1_RX2+					Not used
P14	CSI1_RX2-					Not used
P15	GND				P	Ground
P16	CSI1_RX3+					Not used
P17	CSI1_RX3-					Not used
P18	GND				P	Ground

SMARC Edge Finger		Qualcomm/NXP i.MX7 CPU			Type	Description
Pin#	Pin Name	Ball	Mode	Signal Name		
P19	GbE0_MDI3-				AIO	Qualcomm AR8035 Differential Transmit/Receive Negative Channel 3
P20	GbE0_MDI3+				AIO	Qualcomm AR8035 Differential Transmit/Receive Positive Channel 3
P21	GbE0_LINK100#				O OD	Link Speed Indication LED for 100Mbps Could be able to sink 24mA or more Carrier LED current
P22	GbE0_LINK1000#				O OD	Link Speed Indication LED for 1000Mbps Could be able to sink 24mA or more Carrier LED current
P23	GbE0_MDI2-				AIO	Qualcomm AR8035 Differential Transmit/Receive Negative Channel 2
P24	GbE0_MDI2+				AIO	Qualcomm AR8035 Differential Transmit/Receive Positive Channel 2
P25	GbE0_LINK_ACT#				O OD	Link / Activity Indication LED Driven low on Link (10, 100 or 1000 mbps) Blinks on Activity Could be able to sink 24mA or more Carrier LED current

SMARC Edge Finger		Qualcomm/NXP i.MX7 CPU			Type	Description
Pin#	Pin Name	Ball	Mode	Signal Name		
P26	GbE0_MDI1-				AIO	Qualcomm AR8035 Differential Transmit/Receive Negative Channel 1
P27	GbE0_MDI1+				AIO	Qualcomm AR8035 Differential Transmit/Receive Positive Channel 1
P28	GbE0_CTREF				O	Qualcomm AR8035 Center tap reference voltage for GBE Carrier board Ethernet magnetic
P29	GbE0_MDI0-				AIO	Qualcomm AR8035 Differential Transmit/Receive Negative Channel 0
P30	GbE0_MDI0+				AIO	Qualcomm AR8035: Differential Transmit/Receive Positive Channel 0

SMARC Edge Finger		Qualcomm/NXP i.MX7 CPU			Type	Description
Pin#	Pin Name	Ball	Mode	Signal Name		
P31	SPI0_CS1#	L3	ALT3	UART1_RXD__ ECSPI1_SS1	O	SPI0 Master Chip Select 1 output.
P32	GND				P	Ground
P33	SDIO_WP	C4	ALT0	SD1_WP__ SD1_WP	I	Write Protect
P34	SDIO_CMD	C5	ALT0	SD1_CMD__ SD1_CMD	IO	Command Line
P35	SDIO_CD#	C6	ALT0	SD1_CD__ SD1_CD	I	Card Detect
P36	SDIO_CLK	B5	ALT0	SD1_CLK__ SD1_CLK	O	Clock
P37	SDIO_PWR_EN	B4	ALT0	SD1_RESET_B__ SD1_RESET_B	O	SD card power enable
P38	GND				P	Ground
P39	SDIO_D0	A5	ALT0	SD1_DATA0__ SD1_DATA0	IO	Data path
P40	SDIO_D1	D6	ALT0	SD1_DATA1__ SD1_DATA1	IO	Data path
P41	SDIO_D2	A4	ALT0	SD1_DATA2__ SD1_DATA2	IO	Data path
P42	SDIO_D3	D5	ALT0	SD1_DATA3__ SD1_DATA3	IO	Data path
P43	SPI0_CS0#	H5	ALT0	ECSPI1_SS0__ ECSPI1_SS0	O	SPI0 Master Chip Select 0 output,
P44	SPI0_CLK	H3	ALT0	ECSPI1_SCLK_ ECSPI1_SCLK	O	SPI0 Master Clock output
P45	SPI0_DIN	H4	ALT0	ECSPI1_MISO__ ECSPI1_MISO	I	SPI0 Master Data input (input to CPU, output from SPI device)

SMARC Edge Finger		Qualcomm/NXP i.MX7 CPU			Type	Description
Pin#	Pin Name	Ball	Mode	Signal Name		
P46	SPI0_DO	G5	ALT0	ECSPI1_MOSI__ ECSPI1_MOSI	O	SPI0 Master Data output (output from CPU, input to SPI device)
P47	GND				P	Ground
P48	SATA_TX+					Not used
P49	SATA_TX-					Not used
P50	GND				P	Ground
P51	SATA_RX+					Not used
P52	SATA_RX-					Not used
P53	GND				P	Ground
P54	ESPI1_CS0#	E8	ALT1	SAI2_TXD__ ECSPI1_SS0	O	SPI1 Master Chip Select 0 output
P55	ESPI1_CS1#	D3	ALT3	SD2_CD_B__ ECSP3_SS2	O	SPI1 Master Chip Select 1 output
P56	ESPI1_CK	E9	ALT1	SAI2_RXD__ ECSPI1_SCLK	O	SPI1 Master Clock output
P57	ESPI1_IO_0	D9	ALT1	SAI2_TXFS__ ECSPI3_MISO	I	SPI1 Master Data input (input to CPU, output from SPI device)
P58	ESPI1_IO_1	D8	ALT1	SAI2_TXC__ ECSPI3_MOSI	O	SPI1 Master Data output (output from CPU, input to SPI device)
P59	GND				P	Ground

SMARC Edge Finger		Qualcomm/NXP i.MX7 CPU			Type	Description
Pin#	Pin Name	Ball	Mode	Signal Name		
P60	USB0+	B8		USB_OTG1_DP	B8	Differential USB0 data
P61	USB0-	A8		USB_OTG1_DN	A8	Differential USB0 data
P62	USB0_EN_OC#	N6	ALT1	GPI01_I004__ USB_OTG1_OC	N6	Pulled low by Module OD driver to disable USB0 power Pulled low by Carrier OD driver to indicate over-current situation If this signal is used, a pull-up is required on the Carrier
		P1	ALT1	GPI01_I005__ USB_OTG1_PWR	P1	
P63	USB0_VBUS_DET	C8		Turn on USB_OTG_VBUS	C8	USB host power detection, when this port is used as a device
P64	USB0_OTG_ID	B7		USB_OTG1_ID	B7	USB OTG ID input, active high
P65	USB1+	B10		USB_OTG2_DP	IO	Differential USB0 data pair
P66	USB1-	A10		USB_OTG2_DN	IO	

SMARC Edge Finger		Qualcomm/NXP i.MX7 CPU		Type	Description	
Pin#	Pin Name	Ball	Mode	Signal Name		
P67	USB1_EN_OC#	P2	ALT1	GPI01_I006__	IO OD	Pulled low by Module OD driver to disable USB0 power Pulled low by Carrier OD driver to indicate over-current situation If this signal is used, a pull-up is required on the Carrier
		P3	ALT1	GPI01_I007__ USB_OTG2_PWR		
P68	GND				P	Ground
P69	USB2+					Not used
P70	USB2-					Not used
P71	USB2_EN_OC#					Not used
P72	RSVD					Not used
P73	RSVD					Not used
P74	USB3_EN_OC#					Not used
P75	PCIE_A_RST#	K24	ALT5	EPDC_BDR0__ GPIO2_I028	O	Reset Signal for external devices.
P76	USB4_EN_OC#					Not used
P77	RSVD					Not used
P78	RSVD					Not used
P79	GND				P	Ground
P80	PCIE_C_REFCK+					Not used

SMARC Edge Finger		Qualcomm/NXP i.MX7 CPU		Type	Description
Pin#	Pin Name	Ball	Mode	Signal Name	
P81	PCIE_C_REFCK-				Not used
P82	GND				P Ground
P83	PCIE_A_REFCK+	AC10		PCIE_REFCLKOUT_P	O Differential PCI Express Reference Clock Signals for Lanes A
P84	PCIE_A_REFCK-	AB10		PCIE_REFCLKOUT_N	O Differential PCI Express Reference Clock Signals for Lanes A
P85	GND				P
P86	PCIE_A_RX+	AD11		PCIE_RX_P	I Differential PCIe Link A receive data pair 0
P87	PCIE_A_RX-	AE11		PCIE_RX_N	I Differential PCIe Link A receive data pair 0
P88	GND				P Ground
P89	PCIE_A_TX+	AB11		PCIE_TX_P	O Differential PCIe Link A transmit data pair 0
P90	PCIE_A_TX-	AC11		PCIE_TX_N	O Differential PCIe Link A transmit data pair 0
P91	GND				P Ground
P92	HDMI_D2+ / DP1_LANE0+				Not used
P93	HDMI_D2- / DP1_LANE0-				Not used

SMARC Edge Finger		Qualcomm/NXP i.MX7 CPU			Type	Description
Pin#	Pin Name	Ball	Mode	Signal Name		
P94	GND				P	Ground
P95	HDMI_D1+ / DP1_LANE1+					Not used
P96	HDMI_D1- / DP1_LANE1-					Not used
P97	GND				P	Ground
P98	HDMI_D0+ / DP1_LANE2+					Not used
P99	HDMI_D0- / DP1_LANE2-					Not used
P100	GND				P	Ground
P101	HDMI_CK+ / DP1_LANE3+					Not used
P102	HDMI_CK- / DP1_LANE3-					Not used
P103	GND				P	Ground
P104	HDMI_HPD / DP1_HPD					Not used
P105	HDMI_CTRL_CK / DP1_AUX+					Not used
P106	HDMI_CTRL_DAT / DP1_AUX-					Not used

SMARC Edge Finger		Qualcomm/NXP i.MX7 CPU			Type	Description
Pin#	Pin Name	Ball	Mode	Signal Name		
P107	DP1_AUX_SEL					Not used
P108	GPI00 / CAM0_PWR#	P20	ALT5	EPDC_DATA00__ GPIO2_I000	IO	Camera 0 Power Enable, active low output
P109	GPI01 / CAM1_PWR#	P21	ALT5	EPDC_DATA01__ GPIO2_I001	IO	Camera 1 Power Enable, active low output
P110	GPI02 / CAM0_RST#	N20	ALT5	EPDC_DATA02__ GPIO2_I002	IO	Camera 0 Reset, active low output
P111	GPI03 / CAM1_RST#	N21	ALT5	EPDC_DATA03__ GPIO2_I003	IO	Camera 1 Reset, active low output
P112	GPI04 / HDA_RST#	N22	ALT5	EPDC_DATA04__ GPIO2_I004	IO	HD Audio Reset, active low output
P113	GPI05 / PWM_OUT	N2	ALT1	GPIO1_I001__ PWM1	IO	PWM output
P114	GPI06 / TACHIN	M20	ALT5	EPDC_DATA05__ GPIO2_I005	IO	Tachometer input (used with the GPIO5 PWM)
P115	GPI07 / PCAM_FLD	M22	ALT5	EPDC_DATA07__ GPIO2_I007	IO	PCAM_FLD (Field) signal input
P116	GPI08 / CAN0_ERR#	M21	ALT5	EPDC_DATA06__ GPIO2_I006	IO	CAN0 Error signal, active low input
P117	GPI09 / CAN1_ERR#	L4	ALT5	UART1_TXD__ GPIO4_I001	IO	CAN1 Error signal, active low input
P118	GPI010	M5	ALT5	UART3_RTS__ GPIO4_I006	IO	

SMARC Edge Finger		Qualcomm/NXP i.MX7 CPU			Type	Description
Pin#	Pin Name	Ball	Mode	Signal Name		
P119	GPI011	M6	ALT5	UART3_CTS_ GPIO4_I007	IO	
P120	GND				P	
P121	I2C_PM_CK	J2	ALT0	I2C1_SCL_ I2C1_SCL	IO OD	Power management I2C bus clock
P122	I2C_PM_DAT	K1	ALT0	I2C1_SDA_ I2C1_SDA	IO OD	Power management I2C bus data
P123	BOOT_SEL0#				I	SYSBOOT and Line De-multiplexer Logic Pulled up on Module. Driven by OD part on Carrier.
P124	BOOT_SEL1#				I	SYSBOOT and Line De-multiplexer Logic Pulled up on Module. Driven by OD part on Carrier.
P125	BOOT_SEL2#				I	SYSBOOT and Line De-multiplexer Logic Pulled up on Module. Driven by OD part on Carrier.
P126	RESET_OUT#				O	General purpose reset output to Carrier board.

SMARC Edge Finger		Qualcomm/NXP i.MX7 CPU			Type	Description
Pin#	Pin Name	Ball	Mode	Signal Name		
P127	RESET_IN#				I	Reset input from Carrier board. Carrier drives low to force a Module reset, floats the line otherwise Pulled up on Module. Driven by OD part on Carrier.
P128	POWER_BTN#	AC8		ONOFF	I	Power-button input from carrier board. Carrier to float the line in in-active state. Active low, level sensitive. It is de-bounced on the Module Pulled up on Module. Driven by OD part on Carrier.
P129	SER0_TX	L25	ALT3	EPDC_DATA09__ UART6_TX_DATA	O	Asynchronous serial port data out
P130	SER0_RX	M23	ALT3	EPDC_DATA08__ UART6_RX_DATA	I	Asynchronous serial port data in
P131	SER0_RTS#	L24	ALT3	EPDC_DATA10__ UART6_RTS_B	O	Request to Send handshake line for SER0
P132	SER0_CTS#	L23	ALT3	EPDC_DATA11__ UART6_CTS_B	I	Clear to Send handshake line for SER0
P133	GND				P	Ground
P134	SER1_TX	L6	ALT0	UART2_TX_DATA__ UART2_TX_DATA	O	Asynchronous serial port data out
P135	SER1_RX	L5	ALT0	UART2_RX_DATA__ UART2_RX_DATA	I	Asynchronous serial port data in

SMARC Edge Finger		Qualcomm/NXP i.MX7 CPU			Type	Description
Pin#	Pin Name	Ball	Mode	Signal Name		
P136	SER2_TX	L21	ALT3	EPDC_DATA13__ UART7_TX_DATA	O	Asynchronous serial port data out
P137	SER2_RX	L22	ALT3	EPDC_DATA12__ UART7_RX_DATA	I	Asynchronous serial port data in
P138	SER2_RTS#	L20	ALT3	EPDC_DATA14__ UART7_RTS_B	O	Request to Send handshake line for SER2
P139	SER2_CTS#	K25	ALT3	EPDC_DATA15__ UART7_CTS_B	I	Clear to Send handshake line for SER2
P140	SER3_TX	M2	ALT0	UART3_TX_DATA__ UART3_TX_DATA	O	Asynchronous serial port data out
P141	SER3_RX	M1	ALT0	UART3_RX_DATA__ UART3_RX_DATA	I	Asynchronous serial port data in
P142	GND				P	Ground
P143	CAN0_TX	T3	ALT3	GPI01_I013__ FLEXCAN1_TX	O	CAN0 Transmit output
P144	CAN0_RX	T2	ALT3	GPI01_I012__ FLEXCAN1_RX	I	CAN0 Receive input
P145	CAN1_TX	T6	ALT3	GPI01_I015__ FLEXCAN2_TX	O	CAN1 Transmit output
P146	CAN1_RX	T5	ALT3	GPI01_I014__ FLEXCAN2_RX	I	CAN1 Receive input
P147	VDD_IN				P	Power in
P148	VDD_IN				P	Power in
P149	VDD_IN				P	Power in
P150	VDD_IN				P	Power in
P151	VDD_IN				P	Power in
P152	VDD_IN				P	Power in

<i>SMARC Edge Finger</i>		<i>Qualcomm/NXP i.MX7 CPU</i>			<i>Type</i>	<i>Description</i>
<i>Pin#</i>	<i>Pin Name</i>	<i>Ball</i>	<i>Mode</i>	<i>Signal Name</i>		
<i>P153</i>	<i>VDD_IN</i>				<i>P</i>	<i>Power in</i>
<i>P154</i>	<i>VDD_IN</i>				<i>P</i>	<i>Power in</i>
<i>P155</i>	<i>VDD_IN</i>				<i>P</i>	<i>Power in</i>
<i>P156</i>	<i>VDD_IN</i>				<i>P</i>	<i>Power in</i>

SMARC Edge Finger		Qualcomm/NXP i.MX7 CPU			Type	Description
Pin#	Pin Name	Ball	Mode	Signal Name		
S1	CS1_TX+ / I2C_CAM1_CK	L1	ALT0	I2C4_SCL__ I2C4_SCL	IO OD	Camera I2C bus clock
S2	CS1_TX- / I2C_CAM1_DAT	L2	ALT0	I2C4_SDA__ I2C4_SDA	IO OD	Camera I2C bus data
S3	GND				P	Ground
S4	RSVD					Not used
S5	CSI0_TX- / I2C_CAM0_CK					Not used
S6	CAM_MCK	N5	ALT5	GPI01_I003__ CCM_CLK02	O	Master clock output for CSI camera support
S7	CSI0_TX+ / I2C_CAM0_DAT					Not used
S8	CSI0_CK+					Not used
S9	CSI0_CK-					Not used
S10	GND				P	Ground
S11	CSI0_RX0+					Not used
S12	CSI0_RX0-					Not used
S13	GND				P	Ground
S14	CSI0_RX1+					Not used
S15	CSI0_RX1-					Not used
S16	GND				P	Ground

SMARC Edge Finger		Qualcomm/NXP i.MX7 CPU			Type	Description
Pin#	Pin Name	Ball	Mode	Signal Name		
S17	GbE1_MDI0+				AIO	Qualcomm AR8035 Differential Transmit/Receive Positive Channel 0
S18	GbE1_MDI0-				AIO	Qualcomm AR8035: Differential Transmit/Receive Negative Channel 0
S19	GbE1_LINK100#				O OD	Link Speed Indication LED for 100Mbps Could be able to sink 24mA or more Carrier LED current
S20	GbE1_MDI1+				AIO	Qualcomm AR8035 Differential Transmit/Receive Positive Channel 1
S21	GbE1_MDI1-				AIO	Qualcomm AR8035 Differential Transmit/Receive Negative Channel 1
S22	GbE1_LINK1000#				O OD	Link Speed Indication LED for 1000Mbps Could be able to sink 24mA or more Carrier LED current

SMARC Edge Finger		Qualcomm/NXP i.MX7 CPU			Type	Description
Pin#	Pin Name	Ball	Mode	Signal Name		
S23	GbE1_MDI2+				AIO	Qualcomm AR8035 Differential Transmit/Receive Positive Channel 2
S24	GbE1_MDI2-				AIO	Qualcomm AR8035 Differential Transmit/Receive Negative Channel 2
S25	GND				P	Ground
S26	GbE1_MDI3+				AIO	Qualcomm AR8035 Differential Transmit/Receive Positive Channel 3
S27	GbE1_MDI3-				AIO	Qualcomm AR8035 Differential Transmit/Receive Negative Channel 3
S28	GbE1_CTREF				O	Qualcomm AR8035 Center tap reference voltage for GBE Carrier board Ethernet magnetic

SMARC Edge Finger		Qualcomm/NXP i.MX7 CPU			Type	Description
Pin#	Pin Name	Ball	Mode	Signal Name		
S29	PCIE_D_TX+					Not used
S30	PCIE_D_TX-					Not used
S31	GBE1_LINK_ACK#				O OD	Link / Activity Indication LED Driven low on Link (10, 100 or 1000 mbps) Blinks on Activity Could be able to sink 24mA or more Carrier LED current
S32	PCIE_D_RX+					Not used
S33	PCIE_D_RX-					Not used
S34	GND					Ground
S35	USB4+					Not used
S36	USB4-					Not used
S37	USB3_VBUS_DET					Not used
S38	AUDIO_MCK	E10	ALT0	SAI1_MCLK__ SAI1_MCLK	O	Master clock output to Audio codecs
S39	I2S0_LRCK	D11	ALT0	SAI1_TXFS__ SAI1_TXFS	IO	Left& Right audio synchronization clock
S40	I2S0_SDOUT	E11	ALT0	SAI1_TXD__ SAI1_TXD	O	Digital audio Output
S41	I2S0_SDIN	E12	ALT0	SAI1_RXD__ SAI1_RXD	I	Digital audio Input
S42	I2S0_CK	C11	ALT0	SAI1_TXC__ SAI1_TXC	IO	Digital audio clock

SMARC Edge Finger		Qualcomm/NXP i.MX7 CPU			Type	Description
Pin#	Pin Name	Ball	Mode	Signal Name		
S43	ESPI_ALERT0#					Not used
S44	ESPI_ALERT1#					Not used
S45	RSVD					Not used
S46	RSVD					Not used
S47	GND				G	Ground
S48	I2C_GP_CK	K2	ALT0	I2C2_SCL__ I2C2_SCL	IO OD	General purpose I2C bus clock
S49	I2C_GP_DAT	K3	ALT0	I2C2_SDA__ I2C2_SDA	IO OD	General purpose I2C bus clock
S50	HDA_SYNC / I2S2_LRCK					Not used
S51	HDA_SDO / I2S2_SDOUT					Not used
S52	HDA_SDI / I2S2_SDIN					Not used
S53	HDA_CK / I2S2_CK					Not used
S54	SATA_ACT#					Not used
S55	USB5_EN_OC#					Not used
S56	ESPI_IO_2					Not used
S57	ESPI_IO_3					Not used
S58	ESPI_RESET#					Not used
S59	USB5+					Not used
S60	USB5-					Not used

SMARC Edge Finger		Qualcomm/NXP i.MX7 CPU			Type	Description
<i>Pin#</i>	<i>Pin Name</i>	<i>Ball</i>	<i>Mode</i>	<i>Signal Name</i>		
S61	GND				P	Ground
S62	USB3_SSTX+					Not used
S63	USB3_SSTX-					Not used
S64	GND					Ground
S65	USB3_SSRX+					Not used
S66	USB3_SSRX-					Not used
S67	GND				P	Ground
S68	USB3+					Not used
S69	USB3-					Not used
S70	GND				P	Ground
S71	USB2_SSTX+					Not used
S72	USB2_SSTX--					Not used
S73	GND				P	Ground

SMARC Edge Finger		Qualcomm/NXP i.MX7 CPU		Type	Description
Pin#	Pin Name	Ball	Mode	Signal Name	
S74	USB2_SSRX+				Not used
S75	USB2_SSRX-				Not used
S76	PCIE_B_RST#				Not used
S77	PCIE_C_RST#				Not used
S78	PCIE_C_RX+				Not used
S79	PCIE_C_RX-				Not used
S80	GND				P Ground
S81	PCIE_C_TX+				Not used
S82	PCIE_C_TX-				Not used
S83	GND				P Ground
S84	PCIE_B_REFCK+				Not used
S85	PCIE_B_REFCK-				Not used
S86	GND				P Ground
S87	PCIE_B_RX+				Not used
S88	PCIE_B_RX-				Not used
S89	GND				P Ground
S90	PCIE_B_TX+				Not used
S91	PCIE_B_TX-				Not used
S92	GND				P Ground

SMARC Edge Finger		Qualcomm/NXP i.MX7 CPU			Type	Description
Pin#	Pin Name	Ball	Mode	Signal Name		
S93	DP0_LANE0+					Not used
S94	DP0_LANE0-					Not used
S95	DP0_AUX_SEL					Not used
S96	DP0_LANE1+					Not used
S97	DP0_LANE1-					Not used
S98	DP0_HDP					Not used
S99	DP0_LANE2+					Not used
S100	DP0_LANE2-					Not used
S101	GND				P	Ground
S102	DP0_LANE3+					Not used
S103	DP0_LANE3-					Not used
S104	USB3_OTG_ID					Not used
S105	DP0_AUX+					Not used
S106	DP0_AUX-					Not used
S107	LCD1_BKLT_EN					Not used
S108	LVDS1_CK+ / eDP1_AUX+ / DSI1_CLK+			LVDS1_CK+	O	LVDS1 LCD differential clock pairs
S109	LVDS1_CK- / eDP1_AUX- / DSI1_CLK-			LVDS1_CK-	O	LVDS1 LCD differential clock pairs
S110	GND				P	Ground

SMARC Edge Finger		Qualcomm/NXP i.MX7 CPU			Type	Description
Pin#	Pin Name	Ball	Mode	Signal Name		
S111	LVDS1_0+ / eDP1_TX0+ / DSI1_D0+				AIO	LVDS1 LCD data channel differential pairs 1
S112	LVDS1_0- / eDP1_TX0- / DSI1_D0-				AIO	LVDS1 LCD data channel differential pairs 1
S113	eDP1_HPD					Not used
S114	LVDS1_1+ / eDP1_TX1+ / DSI1_D1+				AIO	LVDS1 LCD data channel differential pairs 2
S115	LVDS1_1- / eDP1_TX1- / DSI1_D1-				AIO	LVDS1 LCD data channel differential pairs 2
S116	LCD1_VDD_ EN					Not used
S117	LVDS1_2+ / eDP1_TX2+ / DSI1_D2+				AIO	LVDS1 LCD data channel differential pairs 3
S118	LVDS1_2- / eDP1_TX2- / DSI1_D2-				AIO	LVDS1 LCD data channel differential pairs 3
S119	GND				P	Ground
S120	LVDS1_3+ / eDP1_TX3+ / DSI1_D3+				AIO	LVDS1 LCD data channel differential pairs 4
S121	LVDS1_3- / eDP1_TX3- / DSI1_D3-				AIO	LVDS1 LCD data channel differential pairs 4
S122	LCD1_BKLT_ PWM					Not used

SMARC Edge Finger		Qualcomm/NXP i.MX7 CPU			Type	Description
Pin#	Pin Name	Ball	Mod e	Signal Name		
S123	RSVD					Not used
S124	GND				P	Ground
S125	LVDS0_0+ / eDP0_TX0+ / DSI0_D0+				AIO	LVDS0 LCD data channel differential pairs 1
S126	LVDS0_0- / eDP0_TX0- / DSI0_D0-				AIO	LVDS0 LCD data channel differential pairs 1
S127	LCD_BKLT_EN	D12	ALT0	SAI1_RX_BCLK__ GPIO6_I017	O	High enables panel backlight
S128	LVDS0_1+ / eDP0_TX1+ / DSI0_D1+				AIO	LVDS0 LCD data channel differential pairs 2
S129	LVDS0_1- / eDP0_TX1- / DSI0_D1-				AIO	LVDS0 LCD data channel differential pairs 2
S130	GND				P	Ground
S131	LVDS0_2+ / eDP0_TX2+ / DSI0_D2+				AIO	LVDS0 LCD data channel differential pairs 3
S132	LVDS0_2- / eDP0_TX2- / DSI0_D2-				AIO	LVDS0 LCD data channel differential pairs 3
S133	LCD_VDD_EN	C21	ALT5	LCD1_RESET__ GOI03_I004	O	High enables panel VDD
S134	LVDS0_CK+ / eDP0_AUX+ / DSI0_CLK+				O	LVDS0 LCD differential clock pairs

SMARC Edge Finger		Qualcomm/NXP i.MX7 CPU			Type	Description
Pin#	Pin Name	Ball	Mode	Signal Name		
S135	LVDS0_CK- / eDP0_AUX- / DSI0_CLK-				O	LVDS0 LCD differential clock pairs
S136	GND				P	Ground
S137	LVDS0_3+ / eDP0_TX3+ / DSI0_D3+				AIO	LVDS0 LCD data channel differential pairs 4
S138	LVDS0_3- / eDP0_TX3- / DSI0_D3-				AIO	LVDS0 LCD data channel differential pairs 4
S139	I2C_LCD_CK	K5	ALT0	I2C3_SCL	IO OD	LCD display I2C bus clock
S140	I2C_LCD_DAT	K6	ALT0	I2C3_SDA	IO OD	LCD display I2C bus clock
S141	LCD_BKLT_PWM	N3	ALT1	GPI01_I002__ PWM2_OUT	O	Display backlight PWM control
S142	RSVD					Not used
S143	GND				P	Ground
S144	eDP0_HPD					Not used
S145	WDT_TIME_OUT#	E19	ALT1	ENET1_CRS__ WDOG2_RST_B_DEB	O	Watchdog-Timer Output
S146	PCIE_WAKE#	K20	ALT5	EPDC_PWRSTAT__ GPIO2_I031	I	PCI Express Wake Event: Sideband wake signal asserted by components requesting wakeup.

SMARC Edge Finger		Qualcomm/NXP i.MX7 CPU			Type	Description
Pin#	Pin Name	Ball	Mode	Signal Name		
S147	VDD_RTC				P	Low current RTC circuit backup power - 3.0V nominal It is sourced from a Carrier based Lithium cell or Super Cap
S148	LID#	C3	ALT5	SD2_WP__ GPIO5_I010	I	Lid open/close indication to Module. Low indicates lid closure (which system may use to initiate a sleep state). Carrier to float the line in in-active state. Active low, level sensitive. Should be de-bounced on the Module Pulled up on Module. Driven by OD part on Carrier.
S149	SLEEP#	E4	ALT5	SD2_DATA00__ GPIO5_I014	I	Sleep indicator from Carrier board. May be sourced from user Sleep button or Carrier logic. Carrier to float the line in in-active state. Active low, level sensitive. Should be de-bounced on the Module. Pulled up on Module. Driven by OD part on Carrier.

SMARC Edge Finger		Qualcomm/NXP i.MX7 CPU		Type	Description	
Pin#	Pin Name	Ball	Mode	Signal Name		
S150	VIN_PWR_BAD#				I	Power bad indication from Carrier board. Module and Carrier power supplies (other than Module and Carrier power supervisory circuits) shall not be enabled while this signal is held low by the Carrier. Pulled up on Module. Driven by OD part on Carrier.
S151	CHARGING#	R1	ALT0	GPI01_I008__ GPI01_I008	I	Held low by Carrier if DC input for battery charger is present. Pulled up on Module. Driven by OD part on Carrier.
S152	CHARGER_PRSENT#	R2	ALT0	GPI01_I009__ GPI01_I009	I	
S153	CARRIER_STBY#	C12	ALT5	SAI1_RXFS__ GPI06_I016	O	The Module shall drive this signal low when the system is in a standby power state

SMARC Edge Finger		Qualcomm/NXP i.MX7 CPU			Type	Description
Pin#	Pin Name	Ball	Mode	Signal Name		
S154	CARRIER_PWR_ON					Carrier board circuits (apart from power management and power path circuits) should not be powered up until the Module asserts the CARRIER_PWR_ON signal.
S155	FORCE_RECOV#				I	Pulled up on Module. Driven by OD part on Carrier.
S156	BATLOW#	G3	ALT5	SD2_RESET__ GPIO5_I0011	I	Battery low indication to Module. Carrier to float the line in in-active state. Pulled up on Module. Driven by OD part on Carrier.
S157	TEST#	P6		TESTMODE	I	Held low by Carrier to invoke Module SD Boot UP. Pulled up on Module. Driven by OD part on Carrier.
S158	GND				P	Ground

Chapter 4

Power Control Signals between SMARC Module and Carrier

This Chapter points out the handshaking rule between *SMARC* module and carrier.

Section include :

- *SMARC-FiMX7* Module Power
- Power Signals
- Power Flow and Control Signals Block Diagram
- Power States
- Power Sequences
- Terminations
- Boot Select

Chapter 4 Power Control Signals between SMARC-FiMX7 Module and Carrier

SMARC modules are designed to be driven with a single +3V to +5.25V input power rail. A +5V is recommended for non-battery operated systems. Unlike Q7 module, there is no separate voltage rail for standby power, other than the very low current *RTC* voltage rail. All module operating and standby power comes from the single set of *VDD_IN* pins. This suits battery power sources well, and is also easy to use with non-battery sources.

SMARC module has specific handshaking rules to the carrier by SMARC hardware specification. To design the carrier board, users need to follow these rules or it might not boot up. Some pull-up and pull-down also need to be cared to make all functions work.

4.1 SMARC-FiMX7 Module Power

4.1.1. Input Voltage / Main Power Rail

The allowable Module DC input voltage range for *SMARC-FiMX7* is from 3.0V to 5.25V. This voltage is brought in on the *VDD_IN* pins and returned through the numerous *GND* pins on the connector. A single 5V DC input is recommended if device is not operated by battery.

Ten pins are allocated to *VDD_IN*. The connector pin current rating is 0.5A per pin. This works out to 5A total for the 10 pins. At the lowest allowed Module input voltage, this would allow up to 16.75W of electrical power to be brought in (with no de-rating on the connector current capability). With a 40% connector current de-rating, up to 10W may be brought in at 3V.

SMARC-FiMX7 typically consumes 1.5~4W depending on solo or quad cores and is pretty safe in using the connector.

4.1.2. No Separate Standby Voltage

There is no separate voltage rail for standby power, other than the very low

current RTC voltage rail. *SMARC-FiMX7* operating and standby power comes from the single set of *VDD_IN* pins. This suits battery power sources well, and is also easy to use with non-battery sources.

4.1.3. RTC/Backup Voltage

RTC backup power is brought in on the *VDD_RTC* rail. The RTC consumption is typically 15 microA or less. The allowable *VDD_RTC* voltage range shall be 2.0V to 3.25V. The *VDD_RTC* rail is sourced from a Carrier based Lithium cell, or it may be left open if the RTC backup functions are not required. *SMARC-FiMX7* module is able to boot without a *VDD_RTC* voltage source.

Lithium cells, if used on Carrier, shall be protected against charging by a Carrier Schottky diode. The diode is placed in series with the positive battery terminal. The diode anode is on the battery side, and the cathode on the Module *VDD_RTC* side.

Note that if a Super cap is used, current may flow out of the Module *VDD_RTC* rail to charge the Super Cap.

4.1.4. Power Sequencing

The Module signal *CARRIER_PWR_ON* exists to ensure that the Module is powered before the main body of Carrier circuits (those outside the power and power control path on the Carrier). The main body of Carrier board circuits should not be powered until the Module asserts the *CARRIER_PWR_ON* signal as a high. Module hardware will assert *CARRIER_PWR_ON* when all Module supplies necessary for Module booting are up.

The IO power of carrier board will be turn on at the stage of power on sequence. If the IO power of carrier board been turn on earlier than the *SMARC* module, the power on carrier board might feedback to *SMARC* module through IO lines and disturbs the *SMARC* module power on sequence. More seriously, it might cause to the CPU won't boot up. It is always recommended that the power on module has to be earlier than that on carrier board.

The boot up of module depends on when you release the reset signal of your carrier board. The module will boot up when the reset signal on your carrier board is released. Before that, the module will not boot up. That's

Embedian, Inc.

why designer needs to put the *RESET_IN#* in the last stage of power to serve as the "power good" signal of the carrier board.

The module will not boot up till the module power is ready because the carrier board hasn't released the reset signal yet.

The sequence is as follows:

Module Power Ready --> *CARRIER_POWER_ON* -->*RESET_IN#* -->Boot Up

4.1.5. RESET_IN#

The *SMARC* module does not know the IO power status from the carrier board, and put *RESET_IN#* in the last stage of power can serve as the "power good" signal of carrier board. This also assures that the power of carrier board is good when *SMARC* module booting up.

4.1.6. VDD_IO

SMARC 1.0 specification defines the I/O voltage to be 1.8V or 3.3V or both. The 3.3V *VDD_IO* is depreciated from *SMARC* 1.1 and *SMARC* 2.0 specification.

SMARC-FiMX7 supports 1.8V *VDD_IO* only.

4.1.7. Power Bad Indication (VIN_PWR_BAD#)

Power bad indication is from carrier board and is an input signal for Module. Module and Carrier power supplies (other than Module and Carrier power supervisory circuits) will not be enabled while this signal is held low by the Carrier.

This signal has a 100K pull-up on module and is driven by OD part on Carrier.

4.1.8. System Power Domains

It is useful to describe an *SMARC* system as being divided into a hierarchy of three power domains:

1) Battery Charger power domain (can be neglected if the system is not

- battery powered only)
- 2) SMARC Module power domain
- 3) Carrier Circuits power domain

The Battery Charger domain includes circuits that are active whenever either charger input power and / or battery power are available. These circuits may include power supply supervisor(s), battery chargers, fuel gauges and, depending on the battery configuration, switching power section(s) to step down a high incoming battery voltage.

The SMARC Module domain includes the SMARC module.

The Carrier Circuits domain includes “everything else” (and does not include items from the Battery Charger and Module domain, even though they may be mounted on the Carrier).

This is illustrated in the figure below.

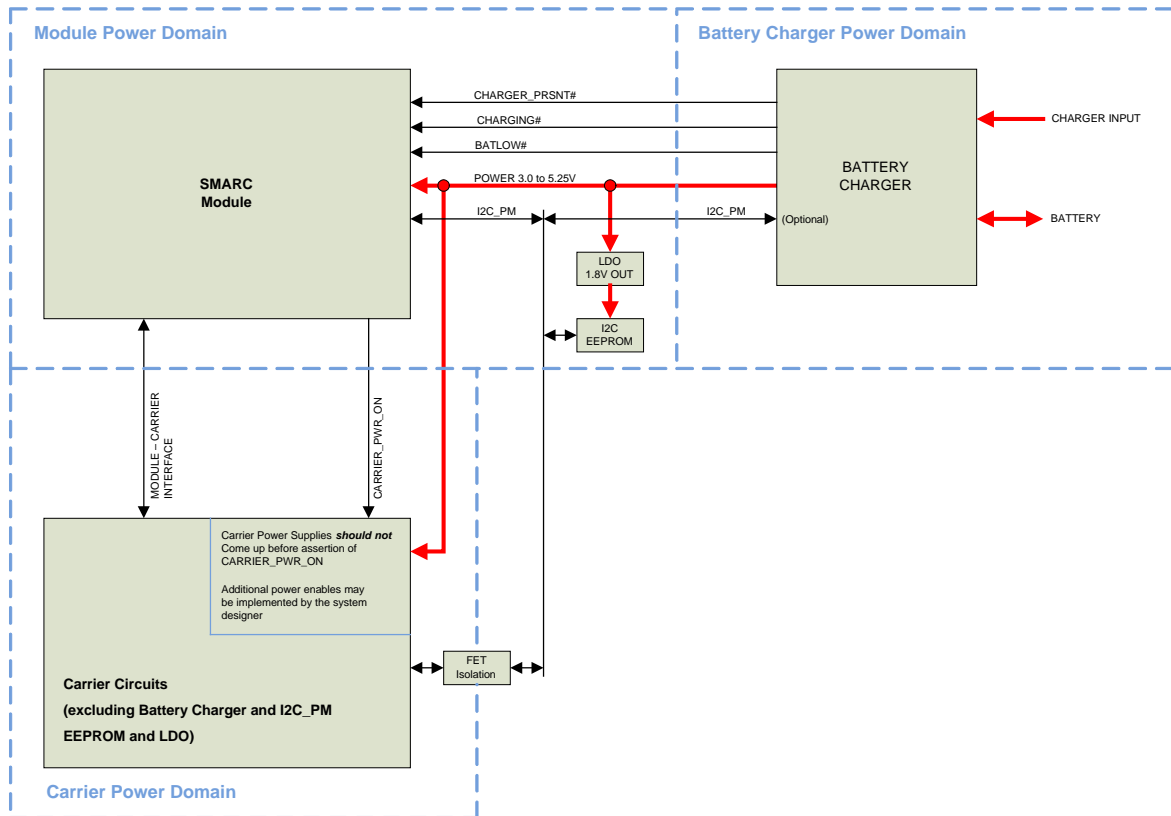

Figure 24 System Power Domains

4.2 Power Signals

4.2.1. Power Supply Signals

SMARC Edge Finger Pin#	Pin Name	I/O	Type	Power Rail	Description
P147, P148, P149, P150, P151,P152, P153, P154, P155, P156	VDD_IN	I	PWR	3.0V~5.25V ¹	Main power supply input for the module
P2, S3, P9, S10, P12, S13, P15, S16, P18, S25, P32, S34, P38, S47, P47, P50, P53, P59, S61, S64, S67, P68, S70, S73, P79, S80, P82, S83, P85, S86,P88, S89, P91, S92, P94, P97, P100, S101, P103, S110, S119, P120, S124, S130, P133, S136, P142, S143	GND	I	PWR		Common signal and power ground
S147	VDD_RTC	I	PWR	3.3V	RTC supply, can be left unconnected if internal RTC is not used

Note: 5V is recommended for non-battery operated system.

4.2.2. Power Control Signals

The input pins listed in the following table are all active low and are meant to be driven by OD (open drain) devices on the Carrier. The Carrier either floats the line or drives it to *GND*. No Carrier pull-ups are needed. The pull-up functions are performed on the Module. The voltage rail that these lines are pulled to on the Module varies, depending on the design, and may be 3.3V or *VDD_IN*.

SMARC Edge Finger		I/O	Type	Power Rail	Description
Pin#	Pin Name				
S150	VIN_PWR_BAD#	I	CMOS	VDD_IN	Power bad indication from Carrier board
S154	CARRIER_PWR_ON	O	CMOS	1.8V	Signal to inform Carrier board circuits being powered up
P126	RESET_OUT#	O	CMOS	1.8V	General purpose reset output to Carrier board.
P127	RESET_IN#	I	CMOS	1.8V	Reset input from Carrier board. Carrier drives low to force a Module reset, floats the line otherwise. Pulled up on Module. Driven by OD part on Carrier.
P128	POWER_BTN#	I	CMOS	1.8V	Power-button input from Carrier board. Carrier to float the line in in-active state. Active low, level sensitive. It is de-bounced on the Module Pulled up on Module. Driven by OD part on Carrier.

4.2.3. Power Management Signals

The pins listed in the following table are related to power management. They will be used in a battery-operated system.

SMARC Edge Finger		I/O	Type	Power Rail	Description
Pin#	Pin Name				
S156	BATLOW#	I	CMOS	1.8V	Battery low indication to Module. Carrier to float the line in in-active state. Pulled up on Module. Driven by OD part on Carrier.
S154	CARRIER_PWR_ON	O	CMOS	1.8V	Signal to inform Carrier board circuits being powered up
S153	CARRIER_STBY#	O	CMOS	1.8V	Module will drive this signal low when the system is in a standby power state
S152	CHARGER_PRSENT#	I	CMOS	1.8V	Held low by Carrier if DC input for battery charger is present. Pulled up on Module. Driven by OD part on Carrier.
S151	CHARGING#	I	Strap	1.8V	Held low by Carrier during battery charging. Carrier to float the line when charge is complete. Pulled up on Module. Driven by OD part on Carrier.

SMARC Edge Finger		I/O	Type	Power Rail	Description
Pin#	Pin Name				
S149	SLEEP#	I	CMOS	1.8V	<p>Sleep indicator from Carrier board. May be sourced from user Sleep button or Carrier logic. Carrier to float the line in in-active state.</p> <p>Active low, level sensitive. Should be de-bounced on the Module.</p> <p>Pulled up on Module.</p> <p>Driven by OD part on Carrier.</p>
S148	LID#	I	CMOS	1.8V	<p>Lid open/close indication to Module. Low indicates lid closure (which system may use to initiate a sleep state). Carrier to float the line in in-active state. Active low, level sensitive. Should be de-bounced on the Module</p> <p>Pulled up on Module.</p> <p>Driven by OD part on Carrier.</p>

4.2.4. Special Control Signals (TEST#)

SMARC-FiMX7 module boots up from an onboard NOR Flash first. The firmware in the SPI NOR flash will read the BOOT_SEL configuration and decides where to load the u-boot.

In some situations like the firmware in NOR flash needed to be upgrade or at factory default where the firmware in NOR flash is empty or at development stage that the firmware in NOR needs to be modified, users will need an alternative way to boot up from SD card first. The TEST# pin serves as this purpose. The TEST# pin is pulled high on module. If carrier board leaves this pin floating or pulls high, the module will boot up from SPI NOR. If carrier board pulls this pin to GND, the module will boot up from SD card. The first stage bootloader in i.MX7 CPU ROM codes will load the 2nd stage bootloader based on the setting of this #TEST pin (S157).

4.3 Power Flow and Control Signals Block Diagram

Following figures shows the power flow and control signals block diagram.

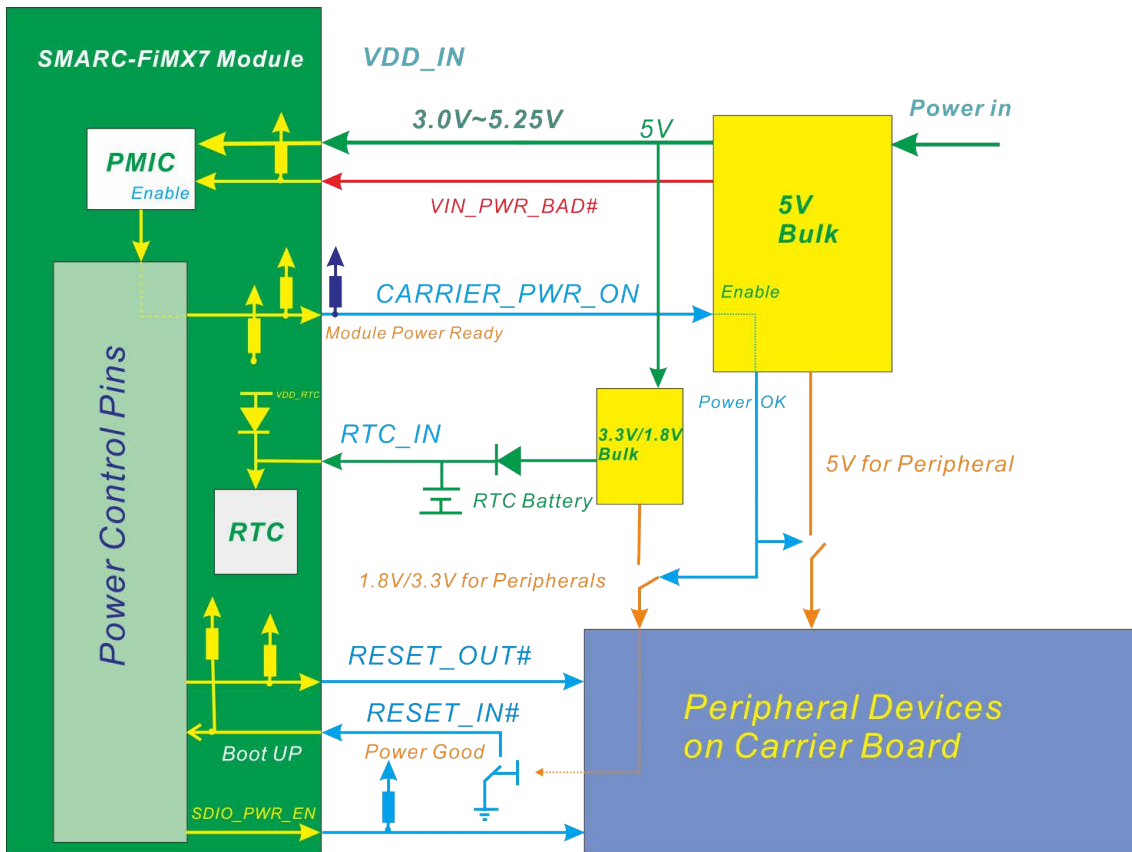

Figure 25: Power Block Diagram

Embedian, Inc.

When main power is supplied from the carrier, a voltage detector will assert *VIN_PWR_BAD#* signal to tell the module and carrier that the power is good. This signal will turn on the PMIC on module to power on the module.

Carrier power circuits in the carrier Power domain should not power up unless the module asserts *CARRIER_PWR_ON*. The module signal *CARRIER_PWR_ON* exists to ensure that the module is powered before the main body of carrier circuits (those outside the power and power control path on the carrier).

The main body of carrier board circuits will not be powered until the module asserts the *CARRIER_PWR_ON* signal being correct. Module hardware will assert *CARRIER_PWR_ON* when all power supplies necessary for module booting are ready. The module will continue to assert signal *RESET_OUT#* after the release of *CARRIER_PWR_ON*, for a period sufficient to allow carrier power circuits to come up. When Carrier power is ready, it will assert *RESET_IN#* to inform module booting up.

If users would like to have SD boot up, *SDIO_PWR_EN* signal have to be pull up to 3.3V on carrier.

Module and carrier power supplies will not be enabled if the *VIN_PWR_BAD#* is held low by carrier. It is a power bad indication signal from carrier and is 100k pull up to *VDD_IN* on module.

4.4 Power States

The *SMARC-FiMX7* module supports different power states. The table below describes the behavior in the different states and which power rails and peripherals are active. Additional power states can be implemented if required using available GPIOs to control additional power domains and peripherals.

Abbr.	Name	Description	Module	Carrier Board
<i>UPG</i>	<i>Unplugged</i>	<i>No power is applied to the system, except the RTC battery might be available</i>	<i>No main VDD_IN applied from fixed DC supply, VDD_IN available if backup battery is implemented</i>	<i>No power supply input, RTC battery maybe inserted</i>
<i>OFF</i>	<i>off</i>	<i>System is off, but the carrier board input supply is available</i>	<i>The main VDD_IN is available, but the CPU and peripherals are not running. Only the PMIC is running</i>	<i>Carrier board provides power for module, the peripheral supplies are not available</i>
<i>SUS</i>	<i>Suspend</i>	<i>System is suspended and waits for wakeup sources to trigger</i>	<i>CPU is suspended, wakeup capable peripherals are running while others might be switched off</i>	<i>Power rails are available on carrier board, peripherals might be stopped by software</i>
<i>RUN</i>	<i>Running</i>	<i>System is running</i>	<i>All power rails are available, CPU and peripherals are running</i>	<i>All power rails are available, peripherals are running</i>
<i>RST</i>	<i>Reset</i>	<i>System is put in reset state by holding RESET_IN# is low</i>	<i>All power rails are available, CPU and peripherals are in reset state</i>	<i>All power rails are available, peripherals are in reset state</i>

The figure below shows a sequence diagram for the different power states. The module automatically enters into the running mode when the main power rail is applied to the module. In the running mode, the system can be set to suspend by software. There might be different wake up sources available. Consult the datasheet for *SMARC-FiMX7* module for more information about the available wakeup events.

In the running state, a shutdown request can be triggered by software. This turns off all power rails on the module and requests the carrier board to switch of the power rails for the peripherals. The module can be brought back to the

running mode in two ways. The module main voltage rail (VDD_IN) can be removed and applied again. If needed, this could also be done with a button and a small circuit. *SMARC-FiMX7* module supports being power cycled by asserting the $RESET_IN\#$ signal (e.g. by pressing the reset button or shunt and relief the reset jumper), please consult the associated module datasheet for more information about the support power cycle methods.

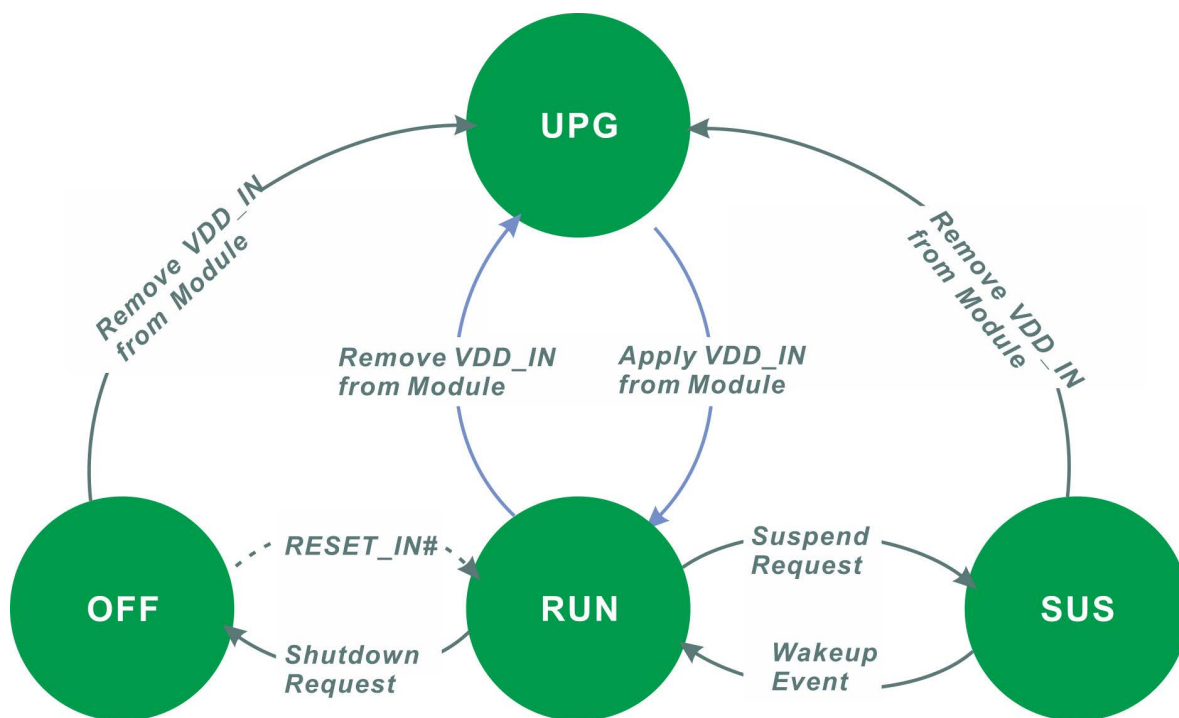

Figure 26: Power States and Transitions

4.5 Power Sequences

When main power is supplied from the carrier, a voltage detector will assert $VIN_PWR_BAD\#$ signal to tell the module and carrier that the power is good. This signal will enable the PMIC on module to power on the module. The module will not power up if the module receives a low-active $VIN_PWR_BAD\#$ signal.

The *SMARC-FiMX7* module starts asserting $CARRIER_PWR_ON$ as soon as the main voltage supply is applied to the module and all module supplies necessary for module booting are up. This is to ensure that the module is powered before the main body of carrier circuits (those outside the power and power control path on the carrier). The module will continue to assert signal

RESET_OUT# after the release of *CARRIER_PWR_ON*, for a period sufficient time (at least 10ms) to allow carrier power circuits that the peripheral supplies need to ramp up.

The peripheral power rails on the carrier board need to ramp up in a correct sequence. The sequence starts normally with the highest voltage (e.g. 5V) followed by the lower voltages (e.g. 3.3V then 1.8V and so on). Peripherals normally require that a lower voltage rails is never present if a higher rail is missing. Check the datasheet of all peripheral components on the carrier board for a proper sequencing. The *SMARC-FiMX7* modules guarantees to apply the reset output *RESET_OUT#* not earlier than 100ms after the *CARRIER_PWR_ON* goes high. This gives the carrier board a sufficient time for ramping up all power rails. *SDIO_PWR_EN* signal have to be pull up to 3.3V on carrier if users would like to have SD boot up functionality.

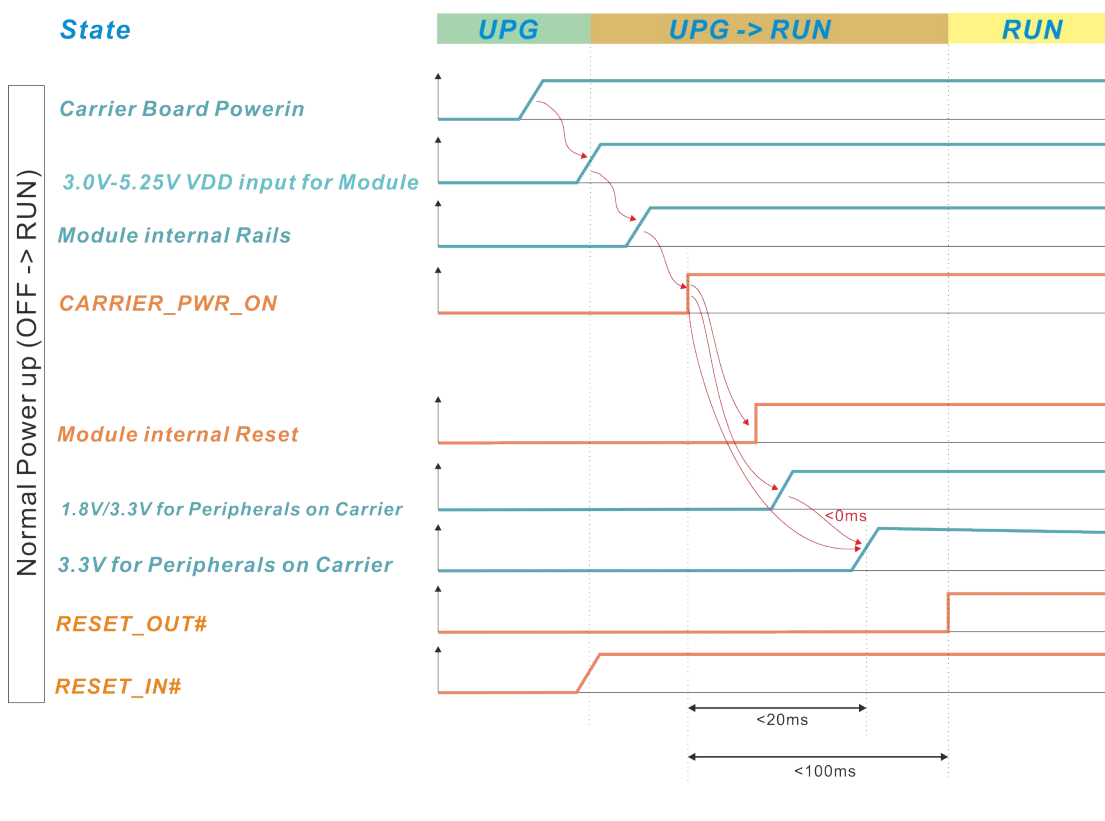

Figure 27: Power-Up Sequence

If the operating system supports it, a shutdown sequence can be initiated. Some systems may benefit from shutting down instead of just removing the main power supply as this allows the operating system to take care of any housekeeping (e.g. bringing mass storage devices to a controlled halt). Some operating system may not provide the shutdown function.

As it is not permitted that a lower voltage rail is present when a higher voltage rail has been switched off, the sequence of shutting down the peripheral voltages needs to be considered. The lower voltages (e.g. peripheral 3.3V) need to ramp down before the higher ones do (e.g. peripheral 5V).

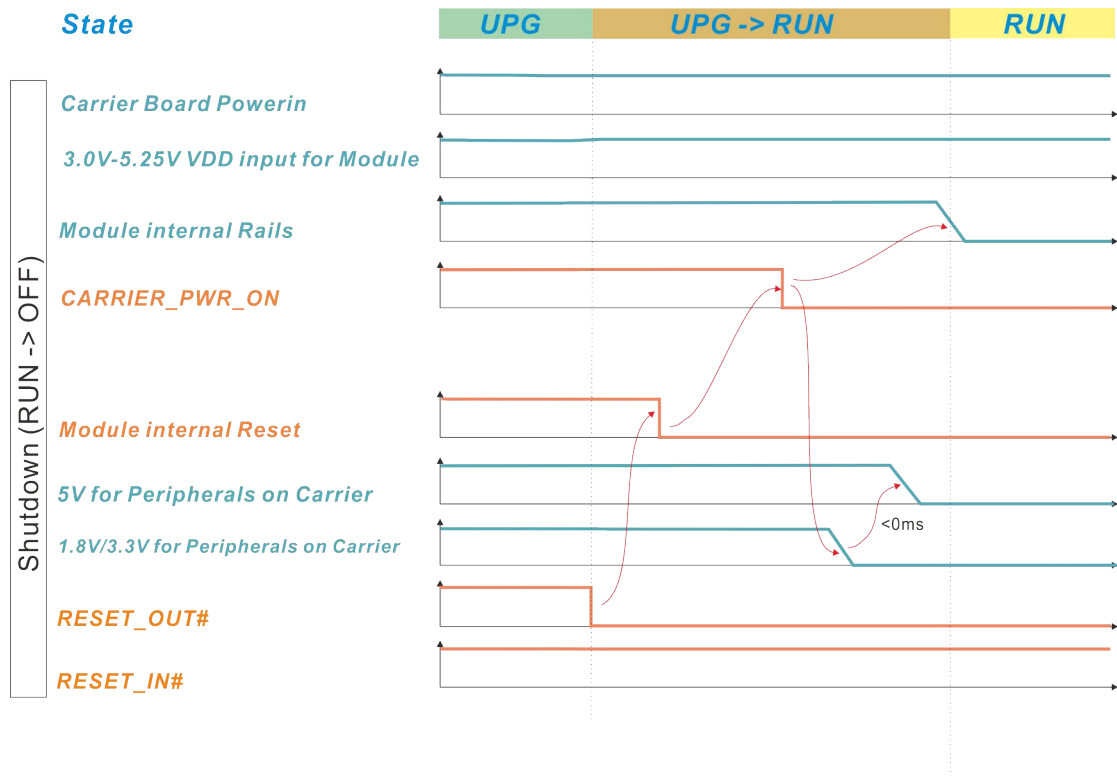

Figure 28: Shutdown Sequence

When the *RESET_IN#* is asserted, a reset cycle is initiated. The module internal reset and the external reset output *RESET_OUT#* are asserted as long as *RESET_IN#* is asserted. If the reset input *RESET_IN#* is de-asserted, the internal reset and the *RESET_OUT#* will remain low for at least 1ms until they are also de-asserted and the module starts booting again. This guarantees a minimum reset time of 1ms even if the reset input *RESET_IN#* is triggered for a short time.

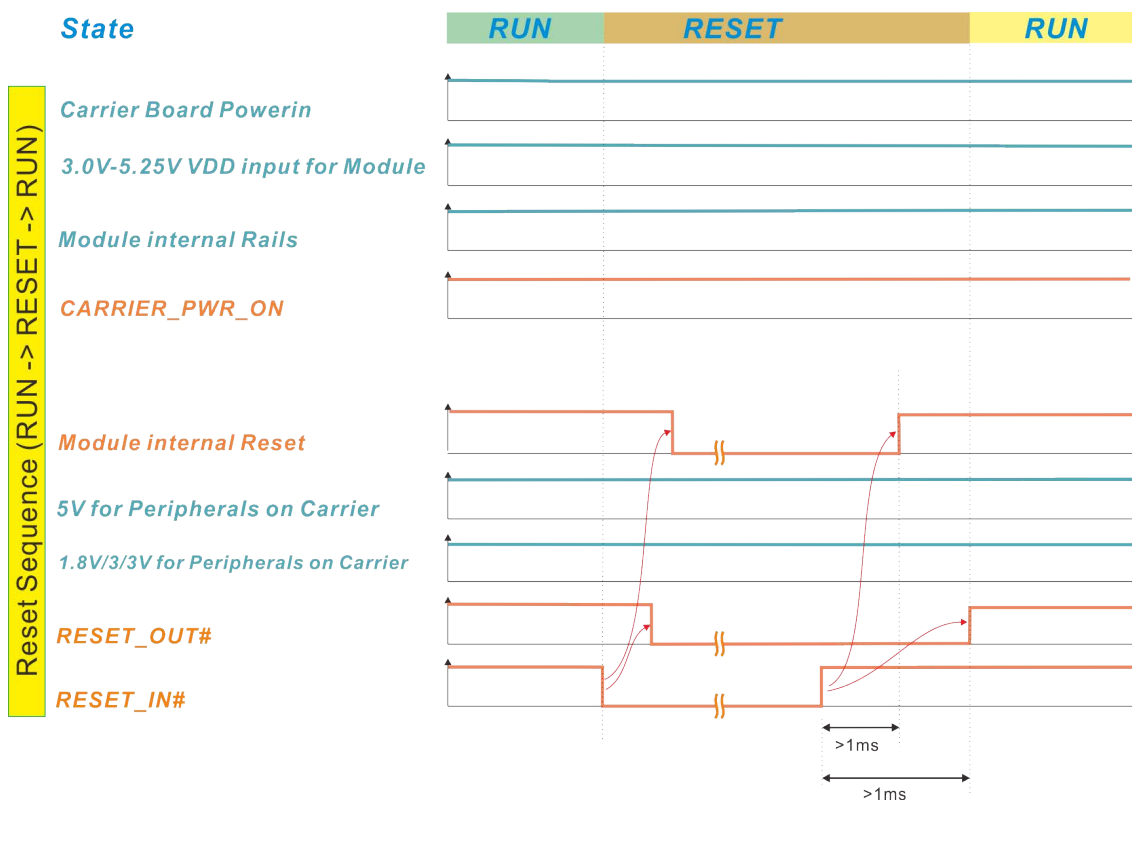

Figure 29: Reset Sequence

4.6 Terminations

4.6.1. Module Terminations

The Module signals listed below will be terminated on the Module. The terminations follow the guidance given in the table below.

<i>Signal Name</i>	<i>Series Termination</i>	<i>Parallel Termination</i>	<i>Notes</i>
<i>I2C_PM_DAT</i>		<i>2.2K pull-up to 1.8V</i>	
<i>I2C_PM_CK</i>		<i>2.2K pull-up to 1.8V</i>	
<i>I2C_LCD_DAT</i>		<i>2.2K pull-up to 1.8V</i>	
<i>I2C_LCD_CK</i>		<i>2.2K pull-up to 1.8V</i>	
<i>I2C_GP_DAT</i>		<i>2.2K pull-up to 1.8V</i>	
<i>I2C_GP_CK</i>		<i>2.2K pull-up to 1.8V</i>	
<i>I2C_CAM_DAT</i>		<i>2.2K pull-up to 1.8V</i>	
<i>I2C_CAM_CK</i>		<i>2.2K pull-up to 1.8V</i>	
<i>PCIE_A_TX+</i>	<i>0.1 uF 0402 capacitor</i>		
<i>PCIE_A_TX-</i>	<i>0.1 uF 0402 capacitor</i>		
<i>SDIO_CD#</i>		<i>10k pull-up to 3.3V</i>	
<i>SDIO_WP</i>		<i>10k pull-up to 3.3V</i>	
<i>VIN_PWR_BAD#</i>		<i>200k pull-up to VIN</i>	

<i>Signal Name</i>	<i>Series Termination</i>	<i>Parallel Termination</i>	<i>Notes</i>
<i>USB[0:1]_EN_OC#</i>		<i>10K pull-up to 3.3V or a switched 3.3V on the Module</i>	<i>Switched 3.3V: if a USB channel is not used, then the USBx_EN_OC# pull-up rail may be held at GND to prevent leakage currents.</i>

4.6.2. Carrier/Off-Module Terminations

The following Carrier terminations are required, if the relevant interface is used. If unused, the SMARC Module pins may be left un-connected.

<i>Module Signal</i>	<i>Carrier Series</i>	<i>Carrier Parallel</i>	<i>Notes</i>
<i>Group Name</i>	<i>Termination</i>	<i>Termination</i>	
<i>GBE[0:1]_MDI[0:3]</i>	<i>Magnetics module appropriate for 10/100/1000 GBE transceivers</i>	<i>Secondary side center tap terminations appropriate for Gigabit Ethernet implementations</i>	
<i>GBE[0:1]_LINK</i> <i>(GBE status LED sinks)</i>		<i>If used, current limiting resistors and diodes to pulled to a positive supply rail</i>	<i>The open drain GBE status signals, GBE_LINK100#, GBE_LINK1000# and GBE_LINK_ACT#, if used, need Carrier based current limiting resistors and LEDs. The LED may be integrated into a Carrier RJ45 jack. A resistor of 68 ohms, and a LED with the anode tied to Carrier 3.3V, is typical.</i>
<i>LVDS LCD</i>		<i>100 ohm resistive termination across the differential pairs at the endpoint of the signal path, usually on the display assembly</i>	
<i>PCIE_A_RX</i>	<i>Series coupling caps near the TX pins of the Carrier board PCIe device</i>		

4.7 Boot Device Selection

SMARC hardware specification defines three pins (*BOOT_SEL[0:2]*) that allow the Carrier board user to select from eight possible boot devices. The first stage of bootloader on *SMARC-FiMX7* will boot up to *SPI NOR* flash first. The firmware on *NOR* flash will read the boot device configuration and load the second stage bootloader from selected boot devices. The *BOOT_SELx#* pins are weakly pulled up on the Module and the pin states decoded by module logic. The Carrier shall either leave the Module pin Not Connected (“Float” in the table below) or shall pull the pin to *GND*, per the table below.

	Carrier Connection			Boot Source
	<i>BOOT_SEL2#</i>	<i>BOOT_SEL1#</i>	<i>BOOT_SEL0#</i>	
0	<i>GND</i>	<i>GND</i>	<i>GND</i>	<i>Carrier SATA</i>
1	<i>GND</i>	<i>GND</i>	<i>Float</i>	<i>Carrier SD Card</i>
2	<i>GND</i>	<i>Float</i>	<i>GND</i>	<i>Carrier eMMC Flash</i>
3	<i>GND</i>	<i>Float</i>	<i>Float</i>	<i>Carrier SPI</i>
4	<i>Float</i>	<i>GND</i>	<i>GND</i>	<i>Module Device(USB)</i>
5	<i>Float</i>	<i>GND</i>	<i>Float</i>	<i>Remote Boot (GBE)</i>
6	<i>Float</i>	<i>Float</i>	<i>GND</i>	<i>Module eMMC Flash</i>
7	<i>Float</i>	<i>Float</i>	<i>Float</i>	<i>Module SPI</i>